

Little GIANT®

6E SERIES



Features

- Handles liquid and solid waste materials up to 1/2" diameter
- Cast iron pump housing with protective epoxy coating for corrosion resistance
- Oil-filled motor housing for lifetime lubrication and rapid heat dissipation
- 1/3 HP shaded pole motor
- Stainless steel screws, bolts and handle
- Mechanical seals (stainless steel spring, nitrile parts, carbon and ceramic faces)
- Bearings: upper and lower sintered sleeve bearings
- Thermal overload protection for extended motor life
- Manual and automatic models
- Automatic operation has 7"-10" "On" level range and 2"-5" "Off" level range
- Piggyback mechanical float switch
- All 115 volt models are UL Listed

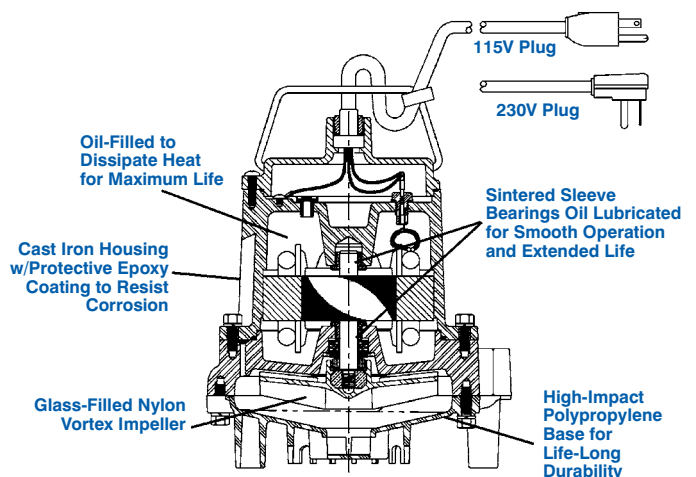

The model 6E Series Sump and Effluent Pumps are for residential and light commercial use. Pumps feature a 1-1/2" discharge with a lift of 20', polypropylene base and polycarbonate cover.

6E SERIES

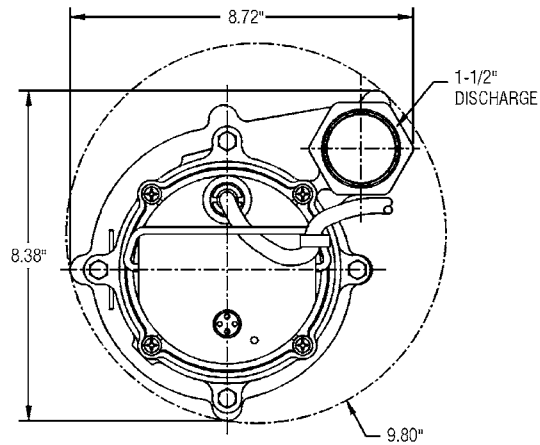
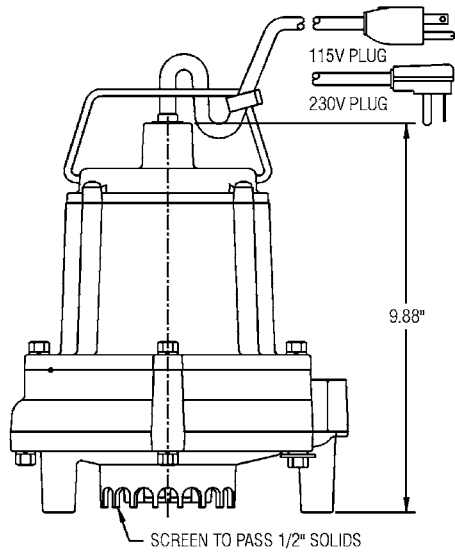

Specifications

Model No.	Item No.	Listing	HP	Volts	Solids Size (dia. in.)	Running Amps/Watts	Performance (GPM@Head)			Shutoff		Cord Length (ft.)	Weight (lbs.)	Dimensions H x L x W (in.)
							5'	10'	15'	Ft.	P.S.I.			
6E-CIM	506500	N/A	1/3	127	1/2"	10/750	54	44	31	20	8.7	25	28	9.9 x 8.8 x 8.5
6E-CIM	506735	CSA	1/3	230*	1/2"	4.8/890	50	42	27	20	8.7	25+	28	9.9 x 8.8 x 8.5
6E-CIM	506775	UL/CSA	1/3	115	1/2"	10/750	50	42	27	20	8.7	25	28	9.9 x 8.8 x 8.5
6E-CIM	506711	UL/CSA	1/3	115	1/2"	10/750	50	42	27	20	8.7	25	28	9.9 x 8.8 x 8.5
6E-CIM	506730	UL/CSA	1/3	230*	1/2"	4.8/890	50	42	27	20	8.7	15	28	9.9 x 8.8 x 8.5
6E-CIM	506710	UL/CSA	1/3	115	1/2"	10/750	50	42	27	20	8.7	10	27	9.9 x 8.8 x 8.5
6E-CIA-RFSN	506740	UL/CSA	1/3	115	1/2"	10/750	50	42	27	20	8.7	10	27	9.9 x 8.8 x 8.5

*50/60 Hz. Performance data based on 60 Hz. CIM — Manual
RFSN — Piggyback Mechanical Float Switch
+ without plug

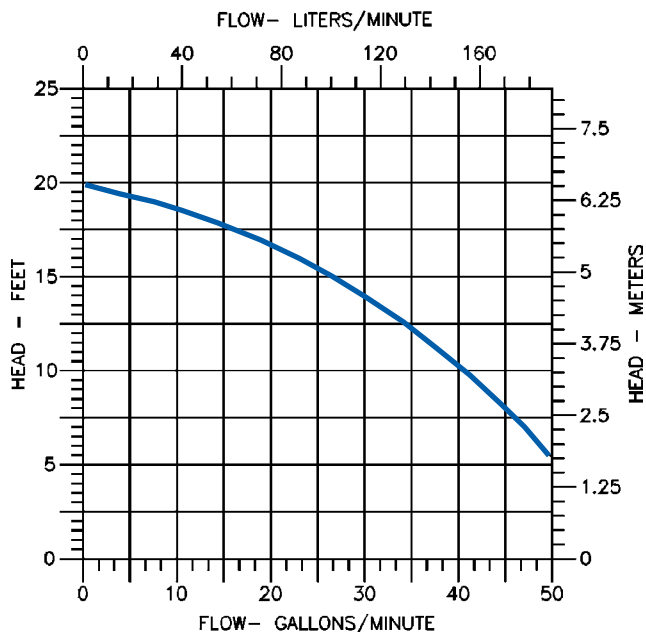

Construction

Cover	Polycarbonate
Motor Housing	Epoxy-coated cast iron
Impeller Material	Nylon
Impeller Type	Vortex
Volute	Epoxy-coated cast iron
Power Cord	SJTW-A
Mechanical Shaft Seal	Nitrile with carbon & ceramic faces
Fasteners	Stainless steel
Shaft	Cold rolled steel
Bearings	Upper and lower sintered sleeve bearings

Little GIANT®
PO Box 12010 • Oklahoma City, OK 73157
Phone: 800.701.7894 • Fax: 800.701.8046
E-mail: customerservice@littlegiant.com