



# User manual

## Logano G234X

Gas central heating boilers

6 720 811 235 (2014/05) US

Please read carefully before use.

**Buderus**

**Content**

<b>1</b>	<b>Safety instructions</b> .....	<b>2</b>
1.1	Key to symbols .....	2
1.2	Safety instructions .....	2
<b>2</b>	<b>Product Information</b> .....	<b>4</b>
2.1	Designated use .....	4
2.2	Product Description .....	4
<b>3</b>	<b>Start-up procedure</b> .....	<b>4</b>
3.1	Turning on heating system .....	4
3.2	Turn off the gas supply .....	5
3.3	Checking the operating pressure, topping up the boiler water, and purging air from the system .....	6
3.3.1	Checking heating system operating pressure .....	6
3.3.2	Topping up the heating water and bleeding the system .....	6
3.4	Operating tips .....	7
<b>4</b>	<b>Shutdown</b> .....	<b>7</b>
4.1	Normal shutdown of the heating system .....	7
4.2	Shutting down the heating system for an extended period .....	7
4.3	Shutting down the heating system in emergencies .....	7
<b>5</b>	<b>Inspection and maintenance</b> .....	<b>8</b>
5.1	General information .....	8
5.2	Why is regular maintenance important? .....	8
5.3	Cleaning and care .....	8
<b>6</b>	<b>Environmental Protection / Disposal</b> .....	<b>8</b>

**1 Safety instructions**

**1.1 Key to symbols**

**Warnings**

Warnings in this document are identified by a warning triangle printed against a grey background. Keywords at the start of a warning indicate the type and seriousness of the ensuing risk if measures to prevent the risk are not taken.

The following keywords are defined and can be used in this document:

- **NOTICE** is used to address practices not related to personal injury.
- **CAUTION** indicates a hazardous situation which, if not avoided, could result in minor to moderate injury.
- **WARNING** indicates a hazardous situation which, if not avoided, could result in death or serious injury.
- **DANGER** indicates that severe personal injury or death may occur.

**Important information**



This symbol indicates important information where there is no risk to people or property.

**Additional symbols**

Symbol	Function
▶	Sequence of steps
→	Cross-reference to another part of the document
•	Listing/list entry
–	Listing/list entry (2nd level)

Table 1 Symbols

**1.2 Safety instructions**

**Risk of fatal injury from failing to consider your own safety**

- ▶ Never risk your own life! Your own safety is paramount.

**If you hear gas leaking**

- ▶ Leave the building immediately.
- ▶ Prevent others from entering the building.
- ▶ Notify the police and fire department from outside the building.
- ▶ **From outside the building**, call the gas supply company and a trained and certified installer or service company.

**If you smell flue gas**

- ▶ Switch off the heating system by shutting off the emergency shutoff switch.
- ▶ Open windows and doors
- ▶ Call a trained and certified installer or service company.

**Risk of fire from soldering and welding**

When soldering and brazing around combustible and flammable material:

- ▶ Take appropriate protective measures.

**If you smell gas**

- ▶ Turn off the gas shutoff valve.
- ▶ Open windows and doors
- ▶ Do not operate any electrical switches or telephones.
- ▶ Do not use any sockets.
- ▶ Extinguish all open flames.
- ▶ No smoking.
- ▶ Do not use lighters.
- ▶ Warn all occupants of the building that they need to leave the building.
- ▶ Do not ring doorbells.
- ▶ **From outside the building:** Notify the police and fire department.
- ▶ **From outside the building:** Call the gas supply company and a trained and certified installer or service company.

**Danger of escaping flue gases**

- ▶ Ensure that the boiler is not be fitted with a barometric damper or a thermally controlled vent damper downstream of the flue connector.
- ▶ Do not tamper with, remove, or attempt to repair the flue gas shutoff switch.
- ▶ When replacing the flue gas shutoff switch, install the new part in the original location.
- ▶ A flue gas shutoff switch tripping more than once indicates a problem with the flue gas system or chimney which must be repaired immediately.
- ▶ Ensure none of the vent pipes and chimneys are damaged or blocked.
- ▶ Connect only one appliance to each flue gas system or chimney.
- ▶ The flue gas system must not feed into or through another air extraction duct.
- ▶ The flue gas system must be inspected once a year. All parts that show any signs of damage or corrosion must be replaced.

**Danger of explosion of flammable gases.**

- ▶ Work on gas components may be carried out only by a trained and certified installer or contractor.
- ▶ Installation, gas and flue gas connections, initial commissioning, power connection, preventive maintenance and repair may be carried out only by a trained and certified installer or contractor.

**Danger of poisoning**

- ▶ Do not close or reduce combustion air vents.
- ▶ The boiler must not be operated until all obstructions have been removed.

**Dangers posed by explosive and easily flammable materials**

- ▶ Never use or store easily flammable or combustible materials (e. g. paper, curtains, clothing, thinners, paints etc.) near the boiler.
- ▶ It is recommended not to store any items within 16 inches (415 mm) of the boiler.

**Danger from neglecting safety devices**

Hot water may escape from the safety valve when the appliance is running.

- ▶ Never shut off safety valves.

**Danger of electric shock when the boiler is open.**

Before opening the boiler:

- ▶ Isolate the heating system from the electrical power supply via the ON/OFF switch or the corresponding building fuse. It is not sufficient just to switch off the controller. Power to the panel must be disconnected.
- ▶ Take measures to ensure that the heating system cannot be accidentally reactivated.
- ▶ Electrical work may be carried out only by qualified and certified electricians.

**Danger due to short-circuits**

To prevent short circuits:

- ▶ Use only genuine wiring spare parts from the manufacturer.
- ▶ Do not attempt to operate an appliance if any part of it has been under water.
- ▶ Replace any appliance that has been under water.

**Risk of system damage due to contaminated combustion air supply**

- ▶ Keep the combustion air free of corrosive substances, e.g. halogenated hydrocarbons from painting operations or beauty salons.
- ▶ Keep combustion air free from dust and lint (e. g. from nearby laundry or agricultural operations).
- ▶ If clean room air is not available, fresh outdoor combustion air must be provided.

**System damage due to improper operation**

- ▶ Use the boiler only for its intended purpose.
- ▶ Operate the boiler only if it has been installed and maintained per the instructions provided in the Installation Manual.
- ▶ Do not attempt to operate an appliance if any part of it is not in working order or is damaged.
- ▶ Use only original spare parts. The use of parts not supplied by the manufacturer may cause damage to the boiler, other property and personal injury. Also, boiler damage caused by the use of unauthorized parts is not covered by the warranty.
- ▶ With **sealed combustion appliances**: do not cover or reduce the size of ventilation openings in doors, windows and walls.
- ▶ If draft-proof windows are installed, ensure an adequate supply of combustion air.

**Notice regarding regulations and legal requirements**

- ▶ The installation must comply with all applicable national, state, and local codes, rules, and regulations.
- ▶ The operator is responsible for the operational safety and regulatory compliance of the heating system.
- ▶ In the Commonwealth of Massachusetts, the appliance must be installed by a licensed plumber or gas fitter.

**Instructing the owner/operator**

- ▶ The installer must instruct the owner and operator on the functionality of the components and the proper operation of the boiler and the heating system.
- ▶ Upon completion of the installation, these instructions should be handed to the owner and operator of the appliance.
- ▶ Inform the owner/operator that they must never carry out any modifications or repairs.

## 2 Product Information

These instructions provide the operator of the heating system with an overview of the use and operation of the boiler.

The Logano G234X floor-standing gas boiler is generally referred to below as a boiler.

### 2.1 Designated use

The boiler is designed for heating central heating system water and indirect provision of domestic hot water (e.g. in a hot water storage tank) in residential buildings or apartment buildings. Any other purpose is considered improper use.

### 2.2 Product Description

The boiler is a low-temperature gas boiler with an atmospheric gas burner.



The floor-standing boiler is fully functional with the factory-installed AquaSmart™.

The boiler consists of the following main components (→ Fig. 1):

- Ignition module and adjustable boiler temperature controller
- Boiler jacket and front cover
- Boiler block with insulation
- Burners

The ignition module and adjustable boiler temperature controller monitor and control all electrical and operational components of the boiler.

The boiler jacket prevents energy loss and acts as soundproofing.

The boiler block transfers the heat generated by the burner to the boiler water. The insulation reduces energy loss.

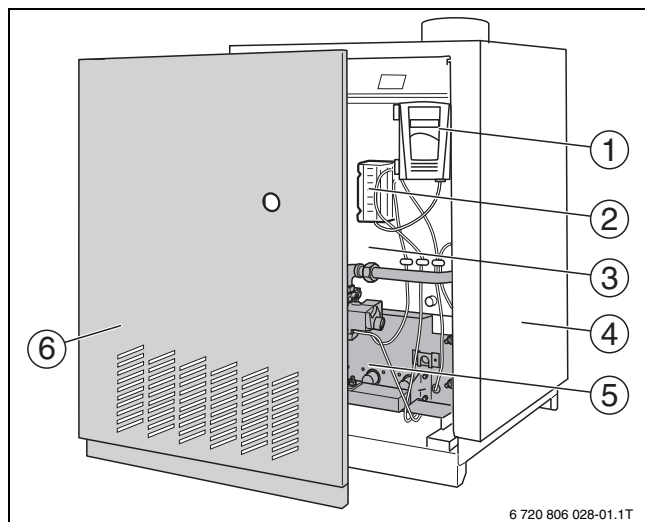

Fig. 1 Main components G234X

- [1] AquaSmart™
- [2] Ignition Control
- [3] Boiler block with insulation
- [4] Boiler jacket
- [5] Burners
- [6] Front wall of boiler

## 3 Start-up procedure

Before commissioning, read the Safety instructions in chapter 1.2 on page 2 for your own safety.

Before commissioning:

- ▶ Ask your heating contractor to provide information about how the boiler works and is operated.



**DANGER:** Risk of fatal injury from failure to observe the commissioning instructions and subsequent incorrect operation!

- ▶ Failure to observe the instructions poses the risk of fire or explosion.

**NOTICE:** System damage due to incorrect operation! This appliance is fitted with an ignition module that automatically starts the pilot burner.

- ▶ Do not light the ignition flame manually.

### 3.1 Turning on heating system

**STOP!** First read the safety instructions in chapter 1.2 on page 2.

- ▶ Set the room thermostats to the lowest setting.
- ▶ Shut off the heating system from the power supply.
- ▶ Turn off the gas shutoff valve.



**DANGER:** Risk to life from fire or explosion!

Any attempt to use force or to repair the gas shutoff valve may cause a fire or explosion.

- ▶ Switch on the ON/OFF switch on the gas valve by hand only.
- ▶ Never use a tool as assistance.
- ▶ If you cannot actuate the ON/OFF switch on the gas valve by hand, do not attempt to repair it.
- ▶ Contact a trained and certified installer.

### Removing the front wall of the boiler

- ▶ Unscrew the locking screws (→ Fig. 2 [2]) at the bottom of the front cover [1], lift front cover up, pull outward and remove to the front.

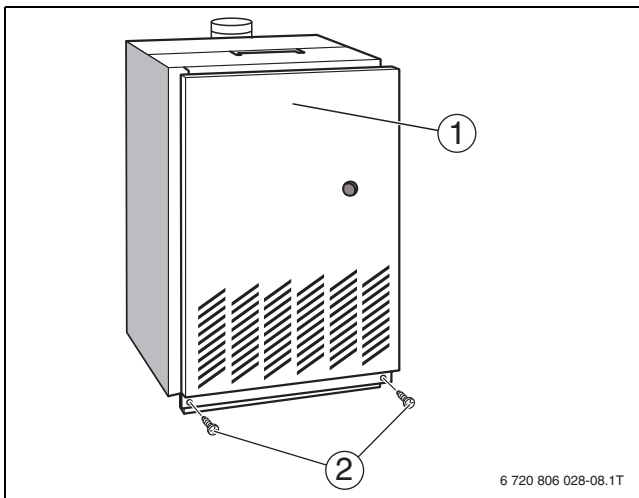

Fig. 2 Installing/removing the front wall of the boiler

- [1] Front wall of boiler  
[2] Locking screws

### Switching on the gas valve

- ▶ Turn the gas valve ON/OFF knob (→ Fig. 3 [1]) clockwise to the **OFF** position. Do not use excessive force.

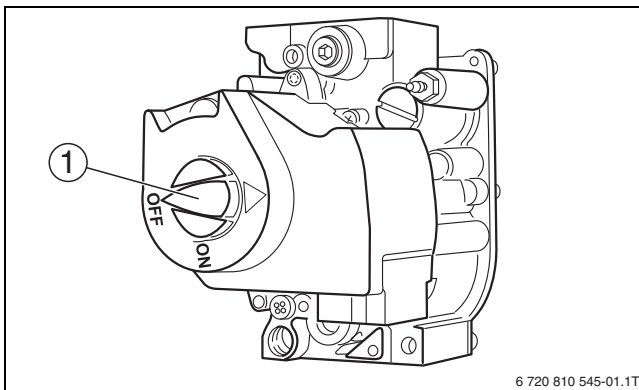

Fig. 3 Gas valve (OFF position)

- [1] ON/OFF knob

- ▶ Wait five (5) minutes until all residual gas has dissipated.
- ▶ Finally, check whether there is any smell of gas (including at floor level).

If there is a gas odor:

- ▶ **STOP!** Follow the safety instructions for "Risk of explosion from escaping gas!" (→ page 2).

If you do not smell gas:

- ▶ Continued to the next step.
- ▶ Turn gas valve ON/OFF knob [1] counterclockwise to the **ON** position. Do not use excessive force.

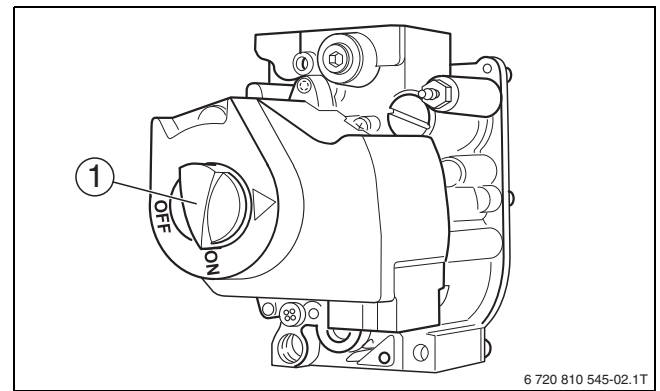

Fig. 4 Gas valve (ON position)

- [1] ON/OFF knob

- ▶ Replace front wall of boiler (→ Fig. 2, page 5).
- ▶ Open gas shutoff valve.
- ▶ Turn on electric power to heating system.
- ▶ Set thermostat to desired room temperature.

If the heating system does not start to operate:

- ▶ Turn off the gas supply (→ chapter 3.2, page 5).
- ▶ After that, inform a customer service technician or the gas utility company.

### 3.2 Turn off the gas supply

- ▶ Set the room thermostats to the lowest setting.
- ▶ Shut off the heating system from the power supply.

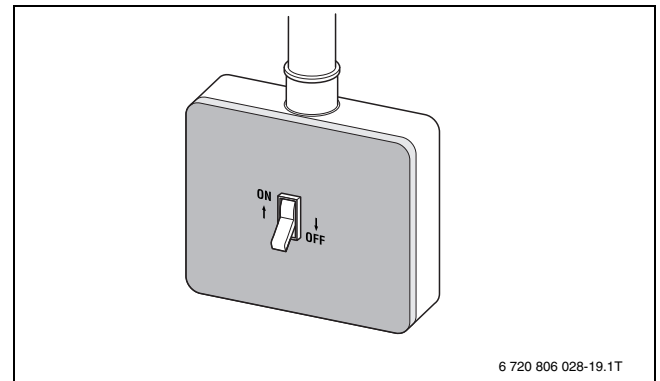

Fig. 5 ON/OFF switch (OFF position)

- ▶ Turn off the gas shutoff valve.
- ▶ Removing the front wall of the boiler (→ Fig. 2, page 5).
- ▶ Turn the gas valve ON/OFF knob (→ Fig. 3 [1], page 5) clockwise to the **OFF** position. Do not use excessive force.
- ▶ Replace front panel of boiler.

### Flame roll out safety shutoff switch

The boiler is equipped with a flame roll-out switch. If the flue duct in the boiler is blocked, the flame roll-out switch responds.

If the flue duct is blocked:

- ▶ Do not try to light the boiler.
- ▶ Inform a qualified service company.

The vent pipe in the boiler must be checked for blockage and the flame baffle replaced.

The flame roll-out switch is for one-time use only and may not be reused.

**Flue gas monitoring switch**

The boiler is equipped with a flue gas monitor. The flue gas monitor responds if the flue gas outlet in the boiler is blocked. The flue gas monitor is mounted directly on the flue gas collector.

If the flue gas outlet in the boiler is blocked:

- ▶ Do not try to light the boiler.
- ▶ Inform a qualified service company.

The flue gas path must be searched for blockages. The flue gas monitor must be reset. Only then can the boiler be started up again.

**3.3 Checking the operating pressure, topping up the boiler water, and purging air from the system**

The water used for filling the heating system loses a substantial amount of volume in the first few days due to the release of its gas content. This causes air pockets to form and the heating water starts to make noises.

During the first few days after commissioning:

- ▶ Check the operating pressure **daily**.
- ▶ Top up the boiler water as necessary.
- ▶ Then bleed the boiler and the radiators.
- ▶ Afterwards, check the operating pressure monthly. Top up the boiler water as necessary; bleed the boiler and radiators.

After an extended period following commissioning:

- ▶ Check the operating pressure **monthly**.
- ▶ Top up the boiler water as necessary.
- ▶ Then bleed the boiler and the radiators.

**3.3.1 Checking heating system operating pressure**

Your heating contractor will have set the system to the required operating pressure of  $\geq 15$  psi ( $\geq 1$  bar) and entered the setting in Tab. 2.

- ▶ Read the current operating pressure from the temperature/pressure gauge.

If the operating pressure displayed is lower than the required operating pressure of  $\geq 15$  psi ( $\geq 1$  bar):

- ▶ Top up the boiler water.

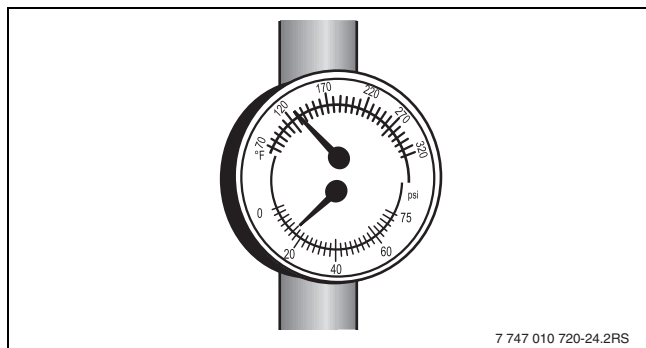

Fig. 6 Pressure/temperature gauge

Operating pressure	
Design operating pressure (optimum setting)	_____ psi
Maximum heating system operating pressure (standard = 30 psi/2 bar)	_____ psi

Table 2 Operating pressure (entered by heating contractor)

**3.3.2 Topping up the heating water and bleeding the system**

- ▶ Have your heating contractor explain the purging and show you where the boiler fill and drain valve is located.

**CAUTION:** Risk of system damage from the stress cracks! If you fill the heating system when it is hot, the resulting temperature stress can cause stress cracks. The boiler will then leak.

- ▶ Only top off the heating system when it is below a supply temperature of 100 °F (38 °C).

**NOTICE:** Risk of system damage due to frequent topping off! Depending on the water quality, the heating system may be damaged by corrosion or scaling if you frequently top up the boiler water.

- ▶ Ask a certified heating contractor if the local water can be used untreated or whether it needs to be treated.

If the boiler water must be treated:

- ▶ Have a certified heating contractor top up the heating system.

If the boiler water must be topped up frequently:

- ▶ Notify a certified heating contractor.

- ▶ Connect the hose to the water tap.
- ▶ Fill the hose with water.
- ▶ Push water-filled hose onto the hose connector of the boiler fill and drain valve.
- ▶ Secure hose with a hose clamp.
- ▶ Open the fill and drain valve.
- ▶ Carefully open the water tap and slowly fill the heating system. Observe the pressure reading on the pressure/temperature gauge (→ Fig. 6).

Once the required operating pressure has been achieved:

- ▶ Close the water valve and the fill & drain valve.
- ▶ Bleed the heating system via the purge valves at the radiators. For this, start with the lowest floor of the building.

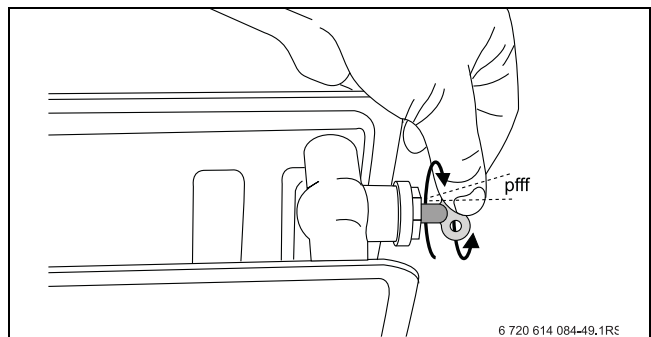

Fig. 7 Bleeding a radiator

- ▶ Tighten the air purge screw again.
- ▶ Check the operating pressure again.

If the operating pressure has dropped as a result of bleeding the system:

- ▶ Add water to the system.

Once the operating pressure remains stable:

- ▶ Remove the hose from the drain & fill valve.

### 3.4 Operating tips

#### The right fuel

To ensure proper operation, the heating system requires fuel of the correct type and grade.

**NOTICE:** Risk of system damage from use of incorrect fuel!

- ▶ Use only the fuel specified.  
The correct fuel is entered in Tab. 3 by the heating contractor.

If the boiler is to be converted to a different fuel type or other fuel:

- ▶ Consult a certified heating contractor.

#### Only use this fuel type:

Stamp/Date/Signature

Table 3 Fuel to be used (entered by heating system installer)

#### Quality of the combustion air

- ▶ Keep the supply of combustion air free of corrosive substances (e. g. halogenated hydrocarbons that contain chlorine or fluorine compounds).  
This prevents corrosion.
- ▶ Do not use or store any chlorine-containing cleaning agents or halogenated hydrocarbons in the boiler room (e. g. in spray cans, solvents and cleansers, paints, adhesives).
- ▶ Keep the combustion air supply free of dust.

If construction work is taking place in the installation room and creating a lot of dust:

- ▶ Shut the boiler down and cover it as necessary.
- ▶ A burner that has been fouled by construction work must be cleaned before being commissioned.

#### Boiler Room Guidelines

**NOTICE:** Risk of system damage from water!

- ▶ In the event of severe risk of flooding, disconnect the boiler from its power supply and shut off the fuel supply before water enters the boiler room.
- ▶ All parts that have been in contact with water must be replaced by a trained and certified installer.

## 4 Shutdown

### 4.1 Normal shutdown of the heating system

- ▶ Place the ON/OFF switch in the **OFF** position (→ Fig. 8). This shuts off power to the boiler and all of its components (e. g. burner, temperature controller).

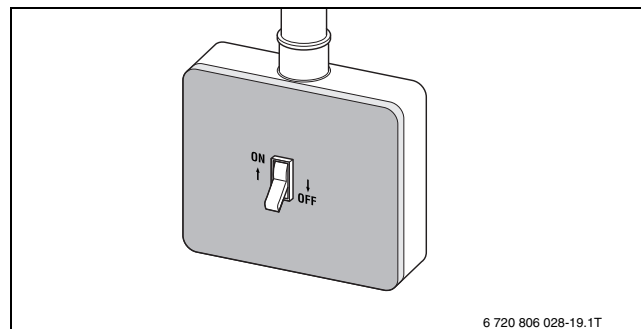

Fig. 8 ON/OFF switch (OFF position)

- ▶ Turn the gas valve ON/OFF knob clockwise to the **OFF** position (→ Fig. 3, page 5).
- ▶ Shut off the fuel supply at the main fuel shutoff valve.

For further shutdown procedure → Documents for the AquaSmart™.

### 4.2 Shutting down the heating system for an extended period

**NOTICE:** Risk of system damage due to freezing!

The heating system can freeze up if it does not operate for an extended period of time and is exposed to temperatures below freezing (e. g. during a power failure, if the power has been switched off, through lack of gas supply, boiler fault).

- ▶ Protect the heating system against frost when temperatures below freezing are expected.
- ▶ With the control unit switched OFF, drain the water from the boiler, the DHW tank and the pipework of the heating system and, as far as possible, from the DHW pipework.

If the boiler is taken out of use for a longer period and there is a risk of frost:

- ▶ Drain the heating system completely.
- ▶ Open the automatic air vent at the highest point in the heating system.
- ▶ Drain the heating water at the lowest point of the heating system by means of the fill and drain valve or a radiator.

### 4.3 Shutting down the heating system in emergencies

- ▶ Have a heating contractor explain what to do in an emergency (e. g. a fire).



Switch OFF the heating system via the emergency shutoff switch or the building circuit breaker/fuse only in emergencies.

- ▶ Never put yourself at risk of fatal injury.  
Your own safety is paramount.
- ▶ Close the main shutoff valve or gas shutoff valve.
- ▶ Isolate the heating system from the electrical power supply via the emergency shutoff switch or the corresponding building fuse.



## 5 Inspection and maintenance

### 5.1 General information

**NOTICE:** Risk of damage to system due to lack of or inadequate cleaning and maintenance.

- ▶ Have a certified heating contractor service and clean the heating system once a year. Have the complete heating system checked for correct operation.
- ▶ Have any faults corrected immediately in order to prevent damage to the system.
- ▶ We recommend that you sign a contract with a certified heating contractor for an annual inspection and maintenance on an as-required basis.



An annual inspection and service are required and are part of the warranty conditions.

### 5.2 Why is regular maintenance important?

Heating systems must be serviced regularly for the following reasons:

- To maintain high-efficiency operation and to operate the heating system economically (low fuel consumption),
- To achieve a high level of operational safety,
- To maintain the cleanest possible combustion,

### 5.3 Cleaning and care

To clean the boiler:

- ▶ Clean the jacket with a damp cloth (soapy solution).
- ▶ Never use scouring or aggressive cleaning agents that would damage the painted surface or plastic components.

## 6 Environmental Protection / Disposal

Environmental protection is one of the fundamental company policies of the Bosch Group.

Quality of products, efficiency and environmental protection are equally important objectives for us. Environmental protection laws and regulations are strictly observed.

To protect the environment, we use the best possible technology and materials, taking into account economic points of view.

### Packaging method

For the packaging, we participate in the country-specific recycling systems, which guarantees optimal recycling.

All packaging materials used are environmentally-friendly and recyclable.

### Old appliances

Old appliances contain materials that must be recycled.

The relevant assemblies are easy to separate, and all plastics are identified. This allows the various components to be sorted for appropriate recycling or disposal.



## Notes

**Notes**

## Notes

**United States and Canada**

Bosch Thermotechnology Corp.  
50 Wentworth Avenue  
Londonderry, NH 03053  
Tel. 603-552-1100  
Fax 603-965-7581  
[www.buderus.us](http://www.buderus.us)  
U.S.A.

Products manufactured by  
Bosch Thermotechnik GmbH  
Sophienstrasse 30-32  
D-35576 Wetzlar  
[www.buderus.com](http://www.buderus.com)

Bosch Thermotechnology Corp. reserves the right  
to make changes without notice due to continuing  
engineering and technological advances.

**Buderus**