

Service instructions

MQ 3-35, MQ 3-45



50/60 Hz

1~

Contents

1.	Type identification	2
1.1	Nameplate.....	2
1.2	Type key	3
2.	Service tools	4
2.1	Special tools	4
2.2	Standard tools	4
3.	Dismantling and assembly.....	5
3.1	General information	5
3.2	Replacing the shaft seal, chambers and impellers.....	6
3.3	Replacing the pressure tank	8
3.4	Replacing the electronic unit, flow sensor and pressure switch	9
3.5	Replacing the motor unit.....	10
4.	Operation.....	11
4.1	Priming.....	11
4.2	Start.....	11
4.3	Stop	11
4.4	Alarm	11
4.5	Auto-reset.....	11
4.6	Manual reset.....	11
4.7	Control panel	12
4.8	Overview	13
4.9	Fault finding.....	14
4.10	Fault finding overview	15
5.	Wiring diagram	24
5.1	Winding resistance measurement.....	24

1. Type identification

1.1 Nameplate

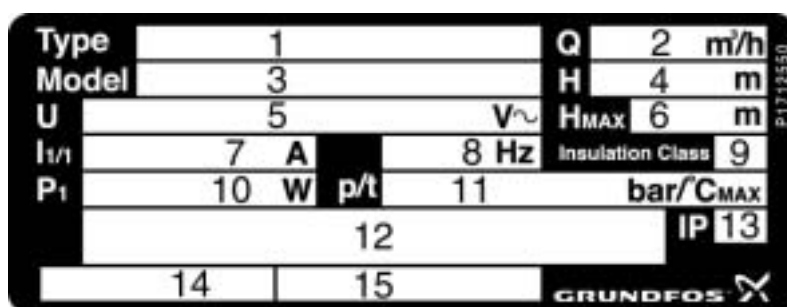

TM02 2363 4201

Pos.	Description	Example
1	Type designation	MQ 3-35 A-O-A-BVBP
2	Rated flow rate [m³/h]	3.0
3	Model Characters: 1 - 8 Production number 9 - 10 Factory code 11 - 14 Production year and week	96440338 P7 0127
4	Operating pressure [m]	22
5	Rated voltage [V~]	1 x 220-240 V
6	Max. head [m]	35
7	Max. current [A]	4.0
8	Frequency [Hz]	50
9	Insulation class	B
10	Power input, P ₁	850
11	Max. system pressure/ liquid temperature [bar/°C _{MAX}]	7.5/35
12	Marks of approval	CE
13	Enclosure class	54
14	Country of origin	Made in Italy
15	Serial number	Serial number 000001G

1.2 Type key

Example	MQ	3 -	35	A-	O-	A-	-BVBP
Pump range							
Rated flow rate [m ³ /h]							
Max. head [m]							
Code for pump version A: Standard							
Code for pipework connection O: External thread							
Code for materials A: Standard							
Code for shaft seal							

2. Service tools

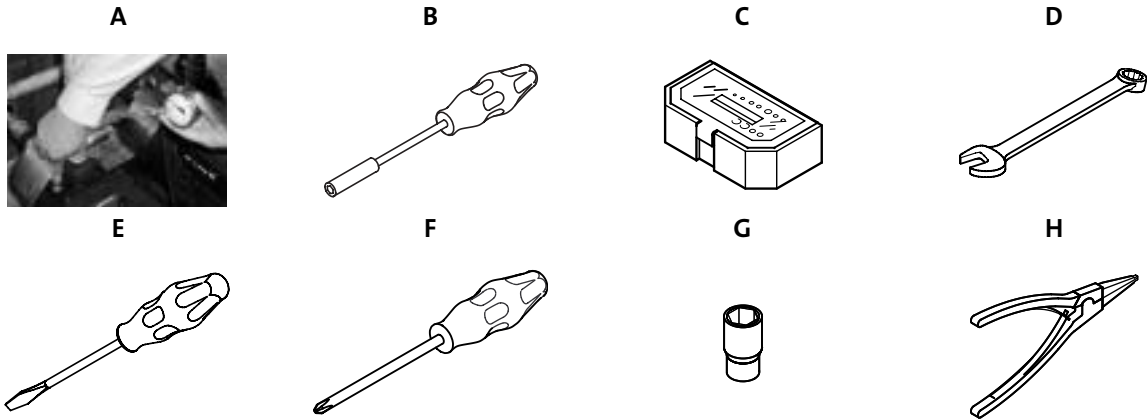

2.1 Special tools

Pos.	Designation	For pos.	Description	Part no.
A	Pressure gauge			SV2061

2.2 Standard tools

Pos.	Designation	For pos.	Description	Part no.
B	Bit holder	G	1/4"	SV2011
C	Bits kit	93	5 mm hexagon	SV2010
D	Ring/open-end spanner	67	M8 - 13 mm	SV0055
E	Screwdriver	91	Straight slot	
F		152, 152b	Cross-head	
G	Hexagon socket driver	42	42 mm	
H	Circlip pliers	111	ø12 mm	

3. Dismantling and assembly

3.1 General information

Position numbers of parts (digits) refer to exploded views, sectional drawings and parts lists; position numbers of tools (letters) refer to section [2. Service tools](#).

3.1.1 Before dismantling

- Disconnect the electricity supply to the motor.
- *Remove the electric cable in accordance with local regulations.*

3.1.2 Before assembly

Gaskets and O-rings should always be replaced when the pump is overhauled.

- Clean and check all parts.
- Order the necessary service kits.
- Replace defective parts by new parts.

3.2 Replacing the shaft seal, chambers and impellers

3.2.1 Removing the shaft seal

1. Slacken and remove the strap pos. 92.
2. Remove the screws pos. 91.
3. Carefully remove the pump sleeve pos. 16 using a screwdriver.
4. Remove the inlet part pos. 6 from the pump sleeve or the top of the chamber stack.
5. Remove the nut pos. 67 and the washer pos. 66. Hold the shaft with a screwdriver in the shaft end.

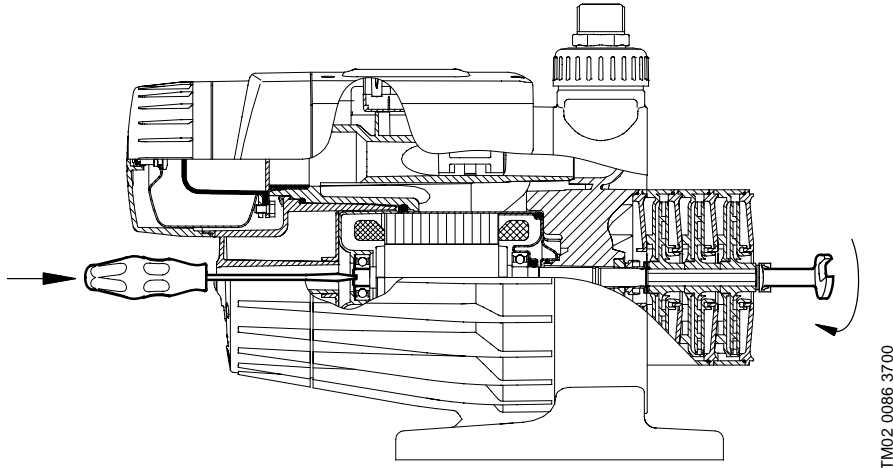

6. Remove the chambers pos. 4 and the impellers pos. 49.
7. Remove the washer pos. 107, the retaining ring pos. 111 and the washer pos. 102.
8. Remove the rotating shaft seal part pos. 104.

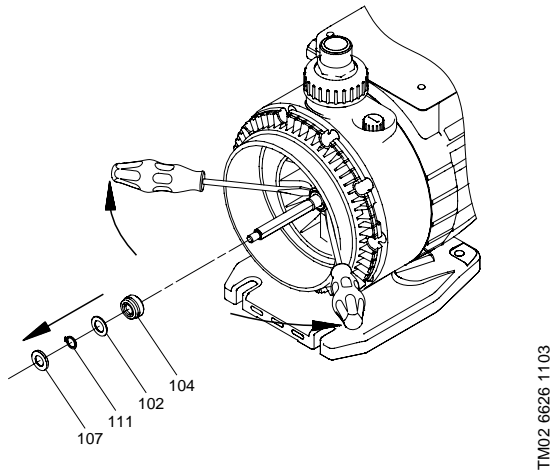

9. Remove the stationary shaft seal part pos. 103 using a screwdriver.

3.2.2 Fitting the shaft seal

1. Fit the stationary shaft seal part pos. 103 with the groove against the intermediate part pos. 2.
2. Fit the rotating shaft seal part pos. 104.
3. Fit the washer pos. 102 (2 mm), the retaining ring pos. 111 and the washer pos. 107.

4. Fit the chambers pos. 4, O-rings pos. 37 and impellers pos. 49 on the motor unit/shaft pos. 150, see drawing. **Note:** There is no O-ring on the chamber next to the intermediate part pos. 2.

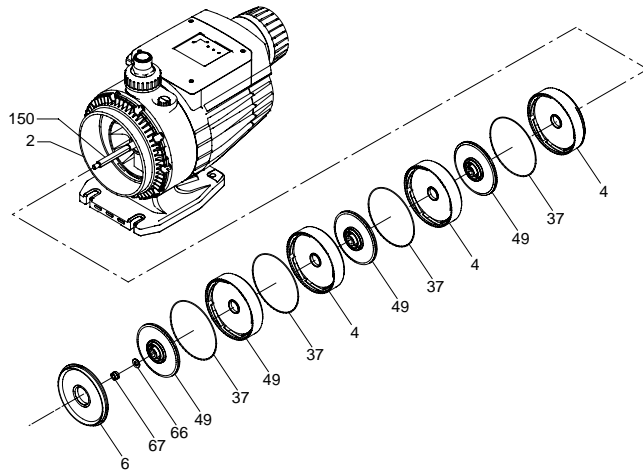

TM02 6628 1203

5. Fit the washer pos. 66 and the nut pos. 67 and tighten it with 7 Nm. Hold the shaft end using a screwdriver.

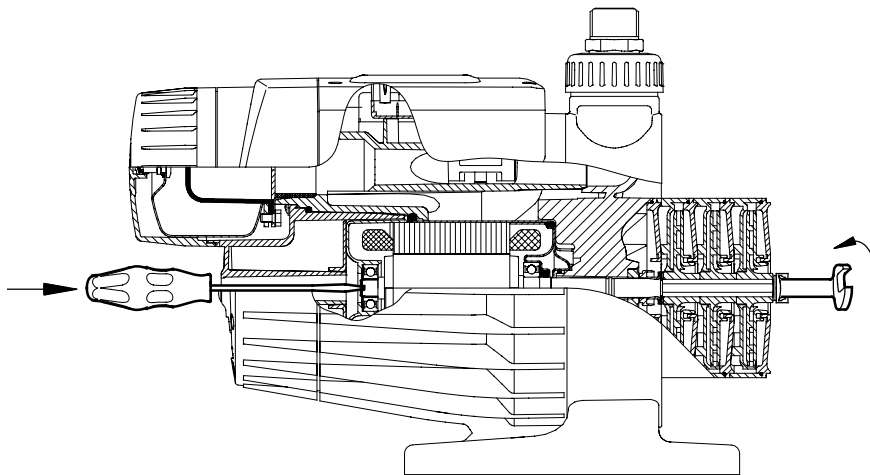

TM02 6704 1403

6. Fit the O-rings pos. 37 to the back of the inlet parts and fit the inlet parts to the chamber stack.
7. Fit the O-ring pos. 37b and lubricate it.
8. Fit the O-ring pos. 37a on the intermediate part pos. 2 and lubricate it.
9. Lubricate and fit the pump sleeve pos. 16. Check that the pin at the bottom of the intermediate part fits the hole of the pump sleeve.
10. Push the pump sleeve into position and tighten the three screws pos. 91.
11. Fit and tighten the strap pos. 92.

3.3 Replacing the pressure tank

3.3.1 Removing the pressure tank

1. Remove the cover pos. 43.
2. Remove the pressure tank pos. 42 including the O-ring pos. 44. It can be loosened using the fingers.
3. If the union nut including O-ring pos. 44 is not removed with the pressure tank, remove it using a 42 mm socket.

3.3.2 Fitting the pressure tank

1. If the pressure tank pos. 42 has been screwed out of the union nut, lubricate the threads of the pressure tank with Loctite 5331 and screw the tank into the union nut.
2. Fit the O-ring pos. 44 and screw the pressure tank pos. 42 into the motor housing pos. 180 by hand.
3. Fit the cover pos. 43.

3.4 Replacing the electronic unit, flow sensor and pressure switch

3.4.1 Removing the electronic unit, flow sensor and pressure switch

1. Slacken the screws pos. 166 and remove the terminal box cover pos. 164.
2. Disconnect the leads and pull them out of the terminal block on the electronic unit pos. 181.
3. Disconnect the flow sensor and pressure switch from the electronic unit pos. 181.
4. Disconnect the earth lead.
5. Remove the electronic unit pos. 181.
6. Remove the capacitor pos. 161 from the terminal box and disconnect the leads.
7. Remove the pressure switch pos. 174a using the fingers.
8. Slacken and remove the screws pos. 166a.
9. Remove the flow sensor cover pos. 184 including the O-ring pos. 187 and flow wheel pos. 185.
10. Pull up the flow wheel shaft pos. 186 and remove the washer pos. 185a.

3.4.2 Fitting the electronic unit, flow sensor and pressure switch

1. Fit the flow wheel shaft pos. 186 and the washer pos. 185a.
2. Fit the flow wheel pos. 185 with the magnet against the cover.
3. Lubricate the O-ring pos. 187 and fit it on the cover pos. 184.
4. Press the cover pos. 184 home. Check that the pin of the flow wheel chamber fits the hole in the cover.
5. Fit and tighten the screws pos. 166a.
6. Lubricate the O-ring pos. 174b with soapy water.
7. Fit and tighten the pressure switch pos. 174a using the fingers.
8. Pull the mains cable into the terminal box.
9. Lead the earth lead round the pressure switch 174a on the outside and the leads round the flow sensor pos. 184 on the inside.
10. Fit the capacitor pos. 161 into the retainer by means of the clip pos. 160.
11. Fit the electronic unit pos. 181 and connect the leads including the earth terminal pos. 176a, see [5. Wiring diagram](#).
12. Fit the terminal box cover pos. 164 including the O-ring pos. 165.
13. Fit and tighten the screws pos. 166.

3.5 Replacing the motor unit

3.5.1 Removing the motor unit

1. Remove the shaft seal, see [3.2.1 Removing the shaft seal](#).
2. Remove the electronic unit, flow sensor and pressure switch, see [3.4.1 Removing the electronic unit, flow sensor and pressure switch](#).
3. Remove the pressure tank, see [3.3.1 Removing the pressure tank](#).
4. Slacken and remove the screws pos. 152 and washers pos. 152a, -b and -c.
5. Remove the end cover pos. 51.
6. Remove the screw for the earth lead pos. 173 on the motor unit pos. 50.
7. Pull the leads to the motor unit out of the terminal box.
8. Press the motor unit pos. 150 out of the motor housing pos. 180.
9. Remove the screws pos. 26, washers pos. 27 and intermediate part pos. 2.
10. Remove the retainer pos. 40a and the O-rings pos. 40.

3.5.2 Fitting the motor unit

1. Lubricate the O-rings pos. 40 and fit the rings and the retainer pos. 40.
2. Lubricate the O-ring pos. pos. 37a and fit it on the motor housing pos. 180.
3. Fit the motor housing pos. 180 to the intermediate part pos. 2.
4. Fit the screws pos. 26 and the washers pos. 27 and tighten diagonally.
5. Lubricate the recess of the O-ring pos. 53 in the motor housing pos. 180.
6. Roll the O-ring pos. 53 on the motor unit pos. 150 and lubricate it.
7. Fit the motor unit in the motor housing pos. 180.
8. Pull the leads from the motor unit into the terminal box.
9. Pull the earth lead into the terminal box. The earth lead lug must not touch the other leads.
10. Fit the earth lead to the motor unit and tighten the screw pos. 173.
11. Lubricate and fit the O-ring pos. 52 to the end cover pos. 51.
12. Fit the end cover pos. 51. The leads from the motor must fit into the slot.
13. Fit the screws pos. 152 and washers pos. 152a, -b and -c and tighten.
14. Fit the pressure tank, see [3.3.2 Fitting the pressure tank](#).
15. Fit the electronic unit, flow sensor and pressure switch, see [3.4.2 Fitting the electronic unit, flow sensor and pressure switch](#).
16. Fit the shaft seal, see [3.2.2 Fitting the shaft seal](#).

4. Operation

4.1 Priming

Before initial start-up, pour approx. 5 litres of water into the pump through the priming port, see the installation and operating instructions. When started, the pump will start to evacuate the air contained in the system. Once it starts to deliver water, the pump will change over to normal operation (start/stop).

If no water is delivered within 5 minutes after start-up, the pump will stop automatically as protection against dry running, and alarm will be indicated.

4.2 Start

The pump starts when

- the consumption is higher than 1.2 l/min or
- the pressure is lower than 2 bar.

4.3 Stop

The pump stops when

- the consumption is lower than 1.2 l/min.

4.4 Alarm

The pump stops in case of

- dry running (if the pressure falls below 2 bar and the consumption below 1.2 l/min, an alarm will be given after 60 seconds)
- overtemperature (thermal switch in motor)
- overloaded motor (thermal switch in motor)
- seized-up motor/pump (thermal switch in motor).

4.5 Auto-reset

If activated, the auto-reset function will cause the pump to restart automatically every 30 minutes for 24 hours in case of any type of fault. After this period, if the fault has not disappeared, the pump will remain in the alarm condition and can only be reset manually, see below.

4.6 Manual reset

The pump can be reset manually by

- pressing the on/off button twice or
- interrupting the supply voltage briefly.

4.7 Control panel

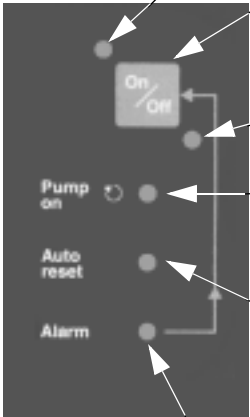
Illustration	Description
	<p>Indicator light (green): Indicates that the pump is ready for operation. When the indicator light is on, the pump will start automatically when water is consumed. The pump will stop a few seconds after the water consumption has ceased.</p>
	<p>On/off button: The pump is started/stopped by means of the on/off button. The on/off button can also be used for manual resetting in case of an alarm condition: - press once for resetting and - press once more for starting.</p>
	<p>Indicator light (red): When the indicator light is on, the pump is on standby.</p>
	<p>Pump on (green): The indicator light is on when the pump is running.</p>
	<p>Auto-reset (green): As standard, this function is activated on delivery. When the indicator light is</p> <ul style="list-style-type: none"> • on, the Auto-reset function is activated. The pump will automatically attempt to restart every 30 minutes after an alarm/fault over a period of 24 hours. After this period, the pump will remain in the alarm condition. • off, the Auto-reset function is deactivated. The pump will not restart after an alarm/fault. <p>The Auto-reset function can be activated/deactivated by pressing the on/off button for 5 seconds.</p> <p>Note: When water is consumed, the pump will start and stop automatically, whether the Auto-reset light is on or off.</p>
	<p>Alarm (red): The indicator light is on when the pump is in alarm condition. The alarm condition may have been caused by:</p> <ul style="list-style-type: none"> - dry running, - overtemperature, - overloaded motor or - seized-up motor/pump.



Note: The pump settings are stored. After supply failure, the pump will automatically revert to its operating condition when the electricity supply is connected again.

4.8 Overview

Before starting the fault finding procedure, check the external installation conditions of the pump. For this purpose, see the installation and operating instructions.

Note: It is important to read this section as well as [4.9 Fault finding](#) and [4.10 Fault finding overview](#) thoroughly.

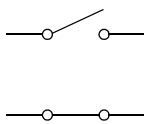
The pictures below show the essential parts that control the MQ pump.

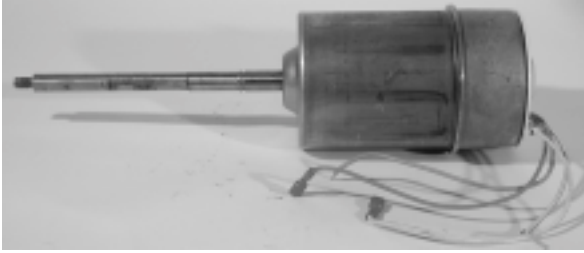
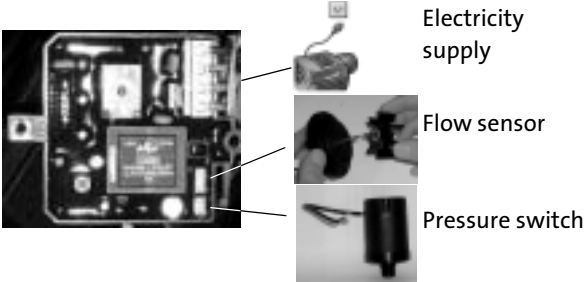
	<p>Pressure switch.</p> <ul style="list-style-type: none"> • $P < 2 \text{ bar} \Rightarrow$ open contact. (Tolerance: 1.8 - 2.2 bar) • $P > 2 \text{ bar} \Rightarrow$ closed contact. (Tolerance: 1.8 - 2.2 bar) 
	<p>Flow sensor.</p> <p>It is important that the magnet part of the flow wheel is pointing upwards against the sensor part. The sensor is positioned in the part with the wire connections.</p>
	<p>Capacitor.</p> <p>Note the wiring of the capacitor.</p> <p>Blue wire from the control panel together with the red wire from the motor. The white wire is solitary.</p>
	<p>Motor (see 5. Wiring diagram).</p>
	<p>Controller and connections.</p>











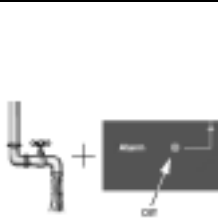



4.9 Fault finding

Fault	Cause	Remedy
1. The pump does not start.	a) Insufficient water.	Check the water supply/suction pipe.
	b) Overheating due to excessive liquid temperature (above +35°C).	Supply cold liquid to the pump.
	c) Overheating due to seized-up/choked-up pump.	Contact your pump supplier.
	d) Too low or too high supply voltage.	Check the supply voltage and correct the fault, if possible.
	e) No electricity supply.	Connect the electricity supply.
	f) No water consumption.	Turn on a tap. Check that the height between the top point of the discharge pipe and the pump does not exceed 15 metres.
	g) The pump is in alarm condition.	Reset the pump by means of the on/off button. See the table in section 4.7.
2. The pump does not stop.	a) The existing pipework is leaking or defective.	Repair the pipework.
3. The pump cuts out during operation.	a) Dry running.	Check the water supply/suction pipe.
	b) Overheating due to excessive liquid temperature (above +35°C).	Supply cold liquid to the pump.
	c) Overheating caused by: <ul style="list-style-type: none"> • high ambient temperature (> +45°C), • overloaded motor or • seized-up motor/pump. 	Contact your pump supplier.
	d) Too low supply voltage.	Check the supply voltage and correct the fault, if possible.
4. The pump starts and stops too frequently.	a) Leakage in suction pipe or air in the water.	Check the water supply/suction pipe/O-rings on the inlet part.
	b) Too low or too high pressure in pressure tank pos. 42.	Check pressure in pressure tank. The pressure must be 1.5 to 1.7 bar.
	c) Seized-up or missing non-return valve.	Clean the valve or fit a new non-return valve.
5. The pump gives electric shocks.	a) Defective earth connection.	Connect the earth connection to the pump in accordance with local regulations.
6. The pumps starts when no water is consumed.	a) Defective non-return valve or the existing pipework is leaking or defective.	Clean the valve or fit a new non-return valve.





If the pump does not start when the fault has been corrected, contact your pump supplier or GRUNDFOS for further information.



4.10 Fault finding overview

Start the pump and allow it to run for a minimum of 5 minutes with the tap turned on. Then observe how the system reacts.

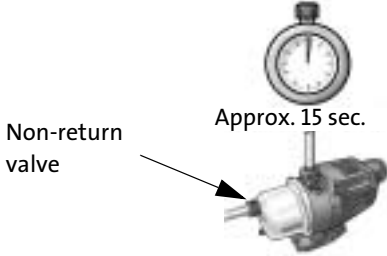

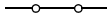
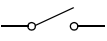
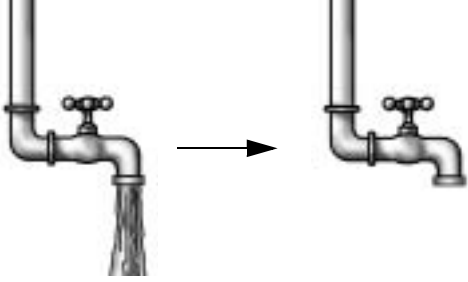

		Typical faults				
	<p>If the tap is opened too quickly, there will be no alarm indication.</p> <p>If the flow is lower than 1.2 l/min., the pump does not start and there will be no alarm indication.</p>	 Pressure switch	 Controller			See 4.10.1 Observation A on page 16.
	Water comes out of the tap, but the pump stops every 15 seconds for a short period and starts again right away. The alarm indicator light is off.	 Pressure switch	 Flow sensor	 Controller		See 4.10.2 Observation B on page 18.
	No water comes out of the tap. The alarm indicator light is on.	 Controller	 Capacitor	 Motor	 Hydraulics	See 4.10.3 Observation C on page 20.
	No water comes out of the tap. The alarm indicator light is off.	 Controller				See 4.10.4 Observation D on page 23.



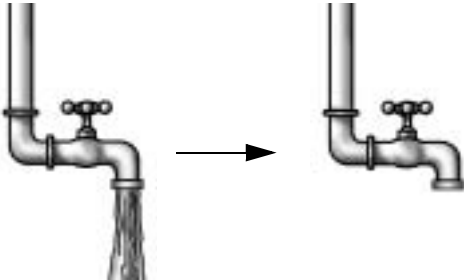

4.10.1 Observation A

<p>A1</p> 	<p>TM02 2369 4201</p> <p>Turn off the tap.</p>
<p>A2</p> 	<p>TM02 2370 4201</p> <p>The system is closed; the pressure must be minimum 2.5 bar. If 2.5 bar is not reached, check the hydraulics. If the pressure is above 2.5 bar, continue the fault finding procedure.</p>
<p>A3</p> 	<p>TM02 2371 4201</p> <p>Wait approx. 15 seconds to see what happens when the pump stops. If the pump does not stop, even when the start/stop button is on, replace the controller. If the pressure falls below 2.5 bar, check the non-return valve in the suction line. If the pressure does not fall, continue the fault finding procedure.</p>
<p>A4</p> 	<p>TM02 2372 4201</p> <p>Disconnect the electricity supply by pulling out the plug.</p>
<p>A5</p> 	<p>TM02 2373 4201</p> <p>Remove the pressure switch plug from the controller.</p>



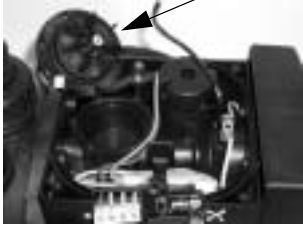

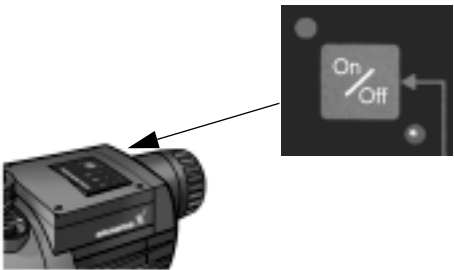
<p>A6</p> <p style="text-align: center;">P > 2.5 bar</p>  <div style="display: flex; justify-content: space-around; align-items: center;"> <div style="text-align: center;">  <p>0 Ω OK</p> </div> <div style="text-align: center;">  <p>∞ Ω Replace</p> </div> </div> <p style="text-align: right; font-size: small;">TM02 2374 4201</p>	<p>At a pressure above 2.5 bar, the switch is closed, and the multimeter must show approx. 0 Ω</p> <p>If the multimeter shows “OL” or M Ω, the contact is open, and the pressure switch must be replaced.</p>
<p>A7</p>  <p style="text-align: right; font-size: small;">TM02 2375 4201/TM02 2376 4201</p>	<p>Turn on the tap. The pressure is removed from the system.</p>
<p>A8</p>  <p style="text-align: right; font-size: small;">TM02 2377 4201</p>	<p>At a pressure below 2 bar, the switch is open, and the multimeter must show “OL” or M Ω.</p> <p>If the multimeter shows approx. 0 Ω, the contact is closed, and the pressure switch must be replaced.</p> <p>If the pressure switch is OK, replace the controller.</p>





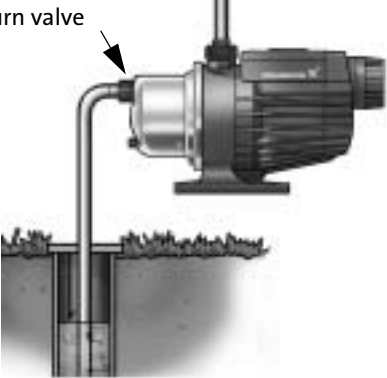

4.10.2 Observation B



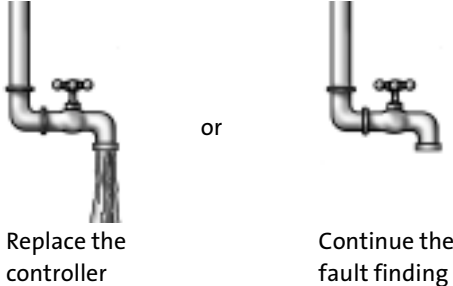

<p>B1</p> 	<p>TM02 2369 4201</p> <p>Turn off the tap.</p>
<p>B2</p> 	<p>TM02 2371 4201</p> <p>If the pump enters an alarm condition after 60 sec., replace the pressure switch. If the pump stops within 15 sec. and does not enter an alarm condition, continue the fault finding procedure.</p>
<p>B3</p> 	<p>TM02 2372 4201</p> <p>Disconnect the electricity supply by pulling out the plug.</p>
<p>B4</p> 	<p>TM02 2375 4201/TM02 2376 4201</p> <p>Turn on the tap. Remove the pressure from the system.</p>
<p>B5</p>  <p>Controller</p>	<p>TM02 2378 4201</p> <p>Remove the controller.</p>

<p>B6</p>  <p>Flow sensor</p> <p style="writing-mode: vertical-rl; transform: rotate(180deg);">TM02 2379 4201</p>	<p>Check for impurities in the flow wheel housing. Replace the flow sensor if defect.</p>
<p>B7</p>  <p style="writing-mode: vertical-rl; transform: rotate(180deg);">TM02 2366 4201</p>	<p>Make sure that the magnet on the flow wheel is fitted against the sensor in the flow sensor cover.</p>
<p>B8</p>  <p style="writing-mode: vertical-rl; transform: rotate(180deg);">TM02 2380 4201</p>	<p>Fit the controller and the cover. Connect the electricity supply.</p>
<p>B9</p>  <p style="writing-mode: vertical-rl; transform: rotate(180deg);">TM02 2381 4201\TM02 2382 4201</p>	<p>Press the on/off button. Do not forget to turn on the tap.</p>
<p>B10</p>  <p style="writing-mode: vertical-rl; transform: rotate(180deg);">TM02 2375 4201</p>	<p>If the pump delivers water without stopping/starting at intervals of 15 seconds, the pump is OK. Otherwise, the controller must be replaced.</p>

4.10.3 Observation C

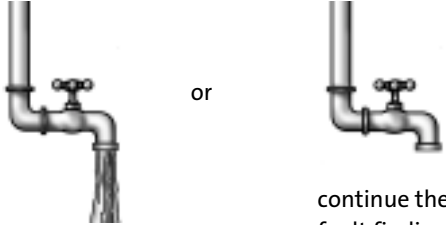
<p>C1 Non-return valve</p>  <p style="text-align: right; font-size: small;">TM02 2383 4201</p>	<p>Check that the inlet conditions are satisfactory.</p>
<p>C2</p>  <p style="text-align: right; font-size: small;">TM01 9696 2600</p>	<p>Prime the pump.</p>
<p>C3</p>  <p style="text-align: right; font-size: small;">TM02 2372 4201</p>	<p>Disconnect the electricity supply by pulling out the plug.</p>
<p>C4</p>  <p style="text-align: right; font-size: small;">TM02 2384 4201</p>	<p>Check if the pump is seized-up by means of a screwdriver. If it is impossible to turn the motor and pump, the hydraulics must be checked. See the exploded drawing.</p>
<p>C5</p>  <p style="text-align: right; font-size: small;">TM02 2385 4201/TM02 2386 4201</p>	<p>Bypass the controller by connecting the motor lead to the mains cable.</p>

<p>C6</p>  <p>TM02 2387 4201</p>	<p>Fix the cover on the pump and connect the electricity supply.</p>
<p>C7</p>  <p>TM02 2388 4201</p>	<p>Wait approx. 5 min. or until water comes out of the tap.</p>
<p>C8</p>  <p>TM02 2375 4201/TM02 2376 4201</p>	<p>If the pump delivers water, the controller must be replaced. If the pump delivers no water, continue the fault finding procedure.</p>
<p>C9</p>  <p>TM02 2372 4201</p>	<p>Disconnect the electricity supply by pulling out the plug.</p>
<p>C10</p>  <p>White → Red → Blue →</p> <p>TM02 2367 4201</p>	<p>Replace the capacitor. If available, a measuring instrument capable of measuring 25 microfarad can be used to measure the capacitor for failures before it is replaced. The blue wire from the capacitor must be connected with the red wire to the motor. The white wire is not connected to other wires.</p>
<p>C11</p>  <p>TM02 2387 4201</p>	<p>Fix the cover on the pump and connect the electricity supply.</p>

<p>C12</p>  <p>(Max. 5 min.)</p> <p>TM02 2388 4201</p>	<p>Wait approx. 5 min. or until water comes out of the tap.</p>
<p>C13</p>  <p>or</p> <p>continue the fault finding</p> <p>TM02 2375 4201/TM02 2376 4201</p>	<p>If the pump delivers water, it is OK. Connect the controller correctly.</p> <p>If the pump does not deliver water, continue the fault finding procedure. The controller continues to be bypassed.</p>
<p>C14</p>  <p>TM02 2372 4201</p>	<p>Disconnect the electricity supply by pulling out the plug.</p>
<p>C15</p>  <p>TM02 2389 4201</p>	<p>Dismantle the hydraulic part and check for defects, dirt and wear.</p>
<p>C16</p>  <p>TM02 2390 4201</p>	<p>Connect the electricity supply by plugging the pump into the mains.</p>
<p>C17</p>  <p>TM02 2391 4201</p>	<p>Check that the motor can rotate.</p> <p>If the motor cannot rotate, replace it.</p> <p>If the motor can rotate, the hydraulics are faulty. See the exploded drawing.</p>

C18



TM02 2380 4201

Do not forget to connect the controller correctly after completing the fault finding procedure.

4.10.4 Observation D

D1



TM02 2380 4201

Replace the controller.

5. Wiring diagram

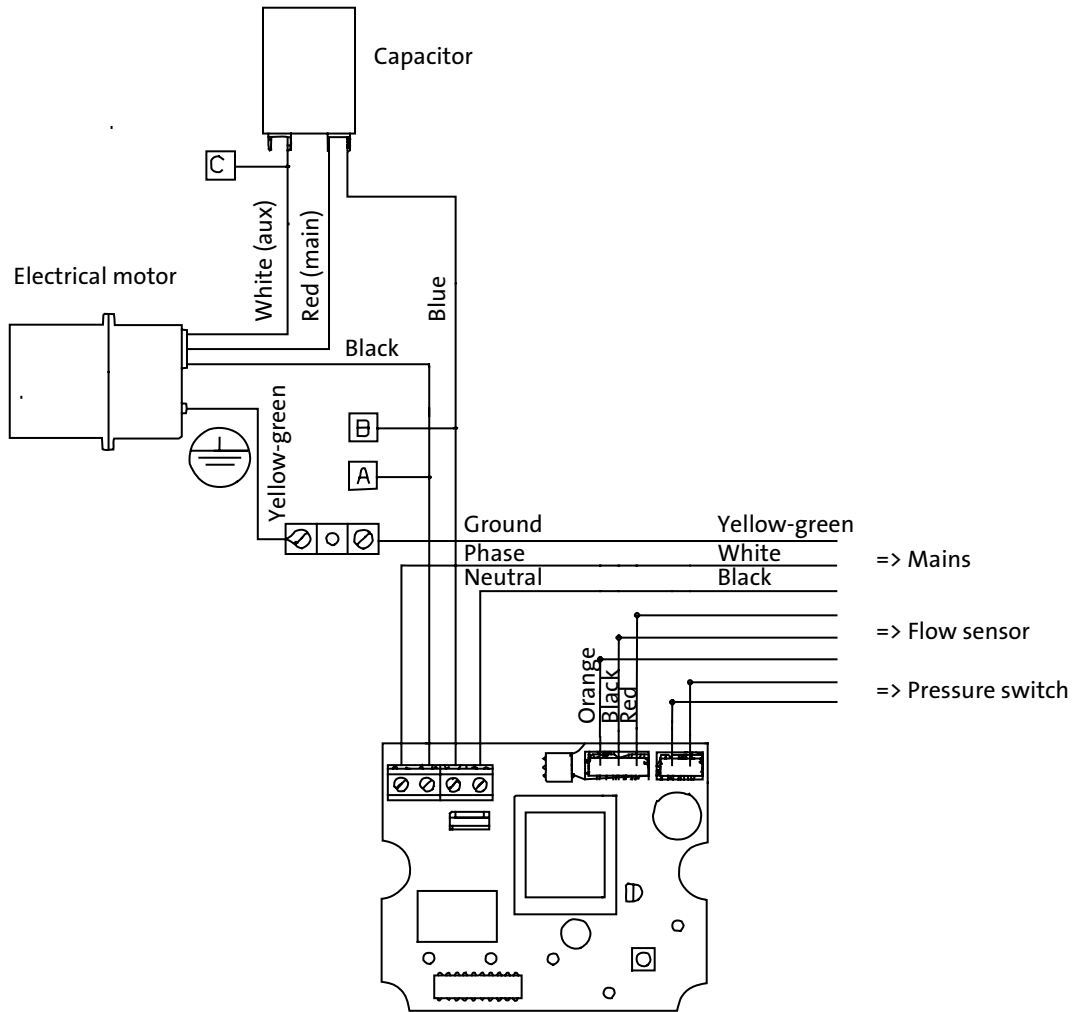

TM02 2424 4401

5.1 Winding resistance measurement

Motor [V/Hz]	Reading point	Winding	Resistance [$\Omega \pm 10\%$]	Ambient temperature	
				[°C]	[°F]
230/50	A-B	Main	6.4	21	70
230/60	A-C	Aux	16.7		
120/60	A-B	Main	1.5		
	A-C	Aux	6.1		

The measurement can be done with or without cables connected to the PCB and the capacitor.