

527LF Foot Valve • Spec Sheet



FEATURES & BENEFITS

- Lead Free Brass*
- 200 WOG
- Threaded Ends
- Stainless Steel Screen
- Buna-N Seat
- End of Line Application
- Sizes 1/2" - 2"

DIMENSIONS

Part #	Size (A)	B	C	D	E	F	G
527T03	1/2"	1.22	0.37	0.84	1.58	2.79	3.23
527T04	3/4"	1.46	0.39	0.94	1.87	3.20	3.35
527T05	1"	1.73	0.45	1.14	2.15	3.74	4.62
527T06	1-1/4"	2.09	0.53	1.26	2.39	4.18	5.08
527T07	1-1/2"	2.36	0.61	1.36	3.09	5.06	5.87
527T08	2"	2.96	0.65	1.73	3.27	5.65	7.17

MATERIAL SPECIFICATIONS

No.	Part	Material
1	Nut	Stainless Steel 304
2	Washer	Stainless Steel 304
3	Spring	Stainless Steel 304
4	Body	Brass C89540
5	O-Ring	NBR
6	Stem	Brass C89540
7	Screw	Brass
8	Cap	Stainless Steel 304
9	Screen	Stainless Steel 304

* This product complies with 0.25% weighted average lead content on wetted surfaces in accordance with CA Health & Safety Code 116875-116880

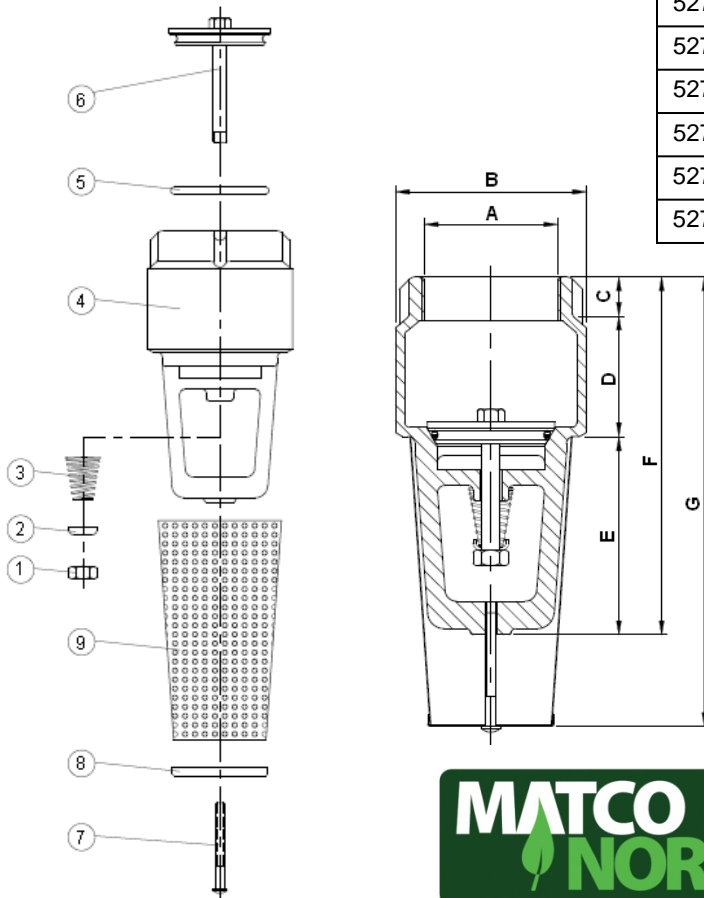

Global sourcing. National compliance. Local service.

CALIFORNIA 5593 Fresca Dr., La Palma CA 90623 • Toll Free: 866-532-8306 • Fax: 866-532-8307
TEXAS 1150 Silber Rd., Houston TX 77055 • Toll Free: 800-935-5456 • Fax: 713-680-2999
NEW YORK PO Box 27, Rt. 22, Brewster NY 10509 • Toll Free: 800-431-2082 • Fax: 845-278-9056
 WEB: www.matco-norca.com EMAIL: mail@matco-norca.com