

Submittal Data

PROJECT:	UNIT TAG:	QUANTITY:
REPRESENTATIVE: _____	TYPE OF SERVICE:	DATE: _____
ENGINEER:	SUBMITTED BY:	DATE:
CONTRACTOR:	APPROVED BY:	DATE:
	ORDER NO.:	DATE:



CMBE 1-75 I-X-C-B-D-E

CMBE is a high-efficiency compact booster suitable for clean water supply and pressure boosting in domestic and light commercial applications. It keeps constant pressure via the integrated speed control.

Note! Product picture may differ from actual product

Conditions of Service		Pump Data		Motor Data	
Liquid:	Water	Liquid temperature range:	0 .. 60 °C	Mains frequency:	60 Hz
Temperature:	20 °C	Maximum ambient temperature:	45 °C	Enclosure class:	IP55
Specific Gravity:	1.000	Shaft seal:	AQQE		
		Product number:	On request		

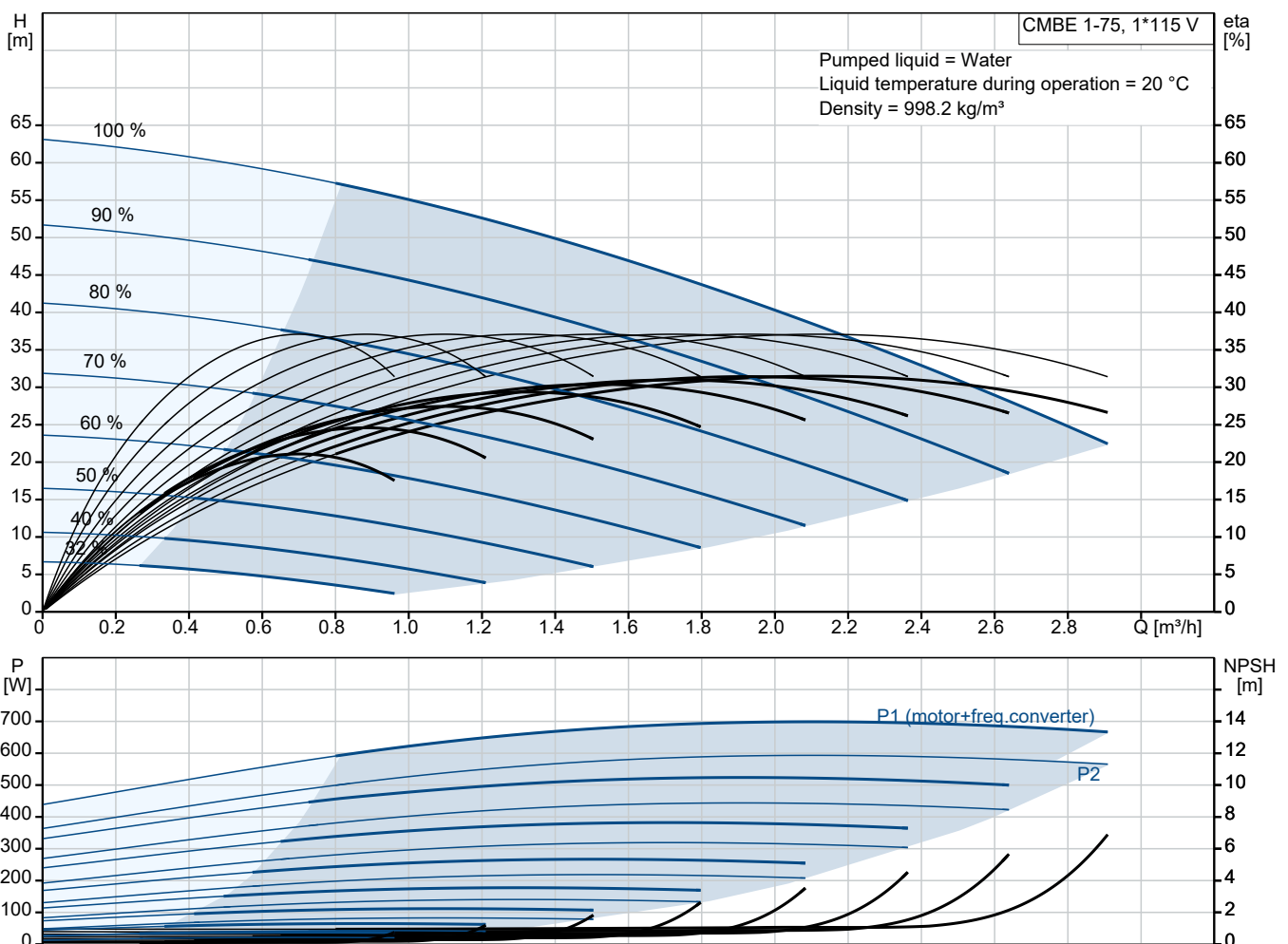

Submittal Data

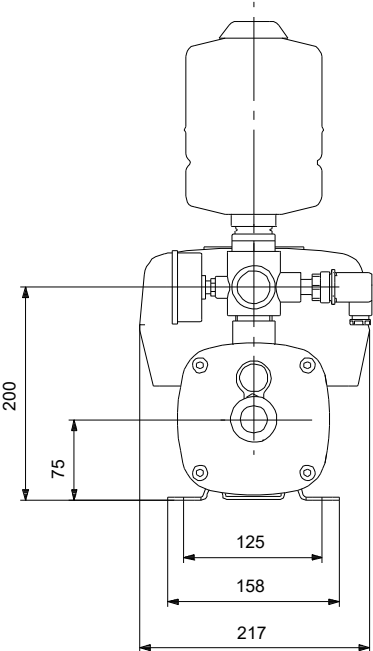
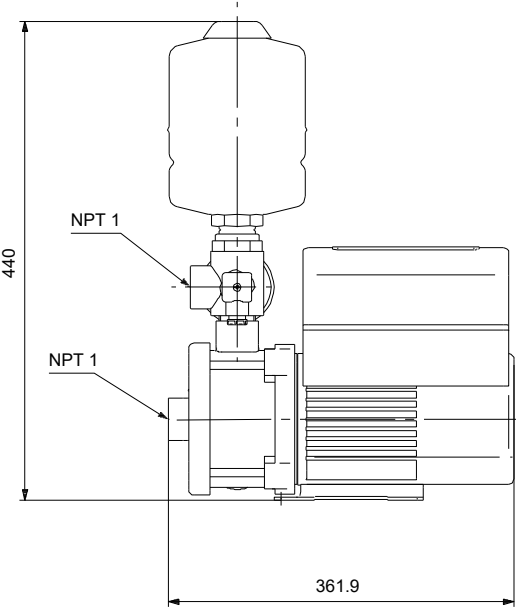

- Materials:**
Pump housing: Stainless steel
Pump housing: AISI 304
Impeller: Stainless steel
Impeller: AISI 304
Impeller: EN 1.4301
Code for rubber: EPDM

Qty. Description

1 **CMBE 1-75 I-X-C-B-D-E**



Note! Product picture may differ from actual product

Product No.: On request

The Grundfos CMBE booster is a compact booster system for water supply in domestic applications. The integrated speed controller enables the CMBE booster to keep constant pressure in the pipe system. A pressure sensor monitoring changes in the water consumption signals the speed controller to change motor speed to adapt performance to the new state.

The CMBE booster is very easy to install. When the system has been connected to the pipes, it is all a matter of inserting the plug into a power supply socket, and the system is operational.

The CMBE booster consists of the following:

- CME pump with integrated frequency converter
- Five-way valve
- expansion tank
- pressure gauge

The Grundfos CMBE booster requires no external motor protection.

The MGE motor incorporates thermal protection against slow overloading and blocking (IEC 34.11: TP 211).

The Grundfos CMBE booster is mainly used for domestic and light commercial water supply or booster systems.

NB:

Suction lift: maximum 1 m, including inlet pipe pressure loss at a liquid temperature of 20 °C (not self-priming).

Controls:

Type of connector: Type B (NEMA 5-15)

Frequency converter: Built-in

Liquid:

Pumped liquid: Water

Liquid temperature range: 0 .. 60 °C

Selected liquid temperature: 20 °C

Density: 998.2 kg/m³

Technical:

Pump speed on which pump data are based: 3780 rpm

Rated flow: 2 m³/h

Rated head: 43.6 m

Code for shaft seal: AQQE

Approvals for drinking water: CULUS DW NSF61

Curve tolerance: ISO9906:2012 3B

Return valve: YES

Start pressure: Integrated Frequency converter

Materials:

Pump housing: Stainless steel

EN 1.4301

AISI 304



Company name:

Created by:

Phone:

Date:

08/08/2024

Qty. Description

1	Impeller:	Stainless steel EN 1.4301 AISI 304
	Installation:	
	Maximum ambient temperature:	45 °C
	Maximum operating pressure:	10 bar
	Pipe connection standard:	ANSI B1.20.1
	Type of inlet connection:	NPT(M)
	Type of outlet connection:	NPT(F)
	Size of inlet connection:	1
	Size of outlet connection:	1
	Pressure rating for connection:	PN 10
	Electrical data:	
	Rated power - P2:	0.75 kW
	Mains frequency:	60 Hz
	Rated voltage:	1 x 115 V
	Maximum current consumption:	8 A
	Rated speed:	360-4000 rpm
	Enclosure class (IEC 34-5):	IP55
	Insulation class (IEC 85):	F
	Length of cable:	1.5 m
	Power plug:	US plug 115V
	Tank:	
	Tank volume:	2 l
	Others:	
	Net weight:	17.6 kg
	Gross weight:	27.4 kg
	Shipping volume:	0.159 m ³

On request CMBE 1-75 I-X-C-B-D-E 60 Hz

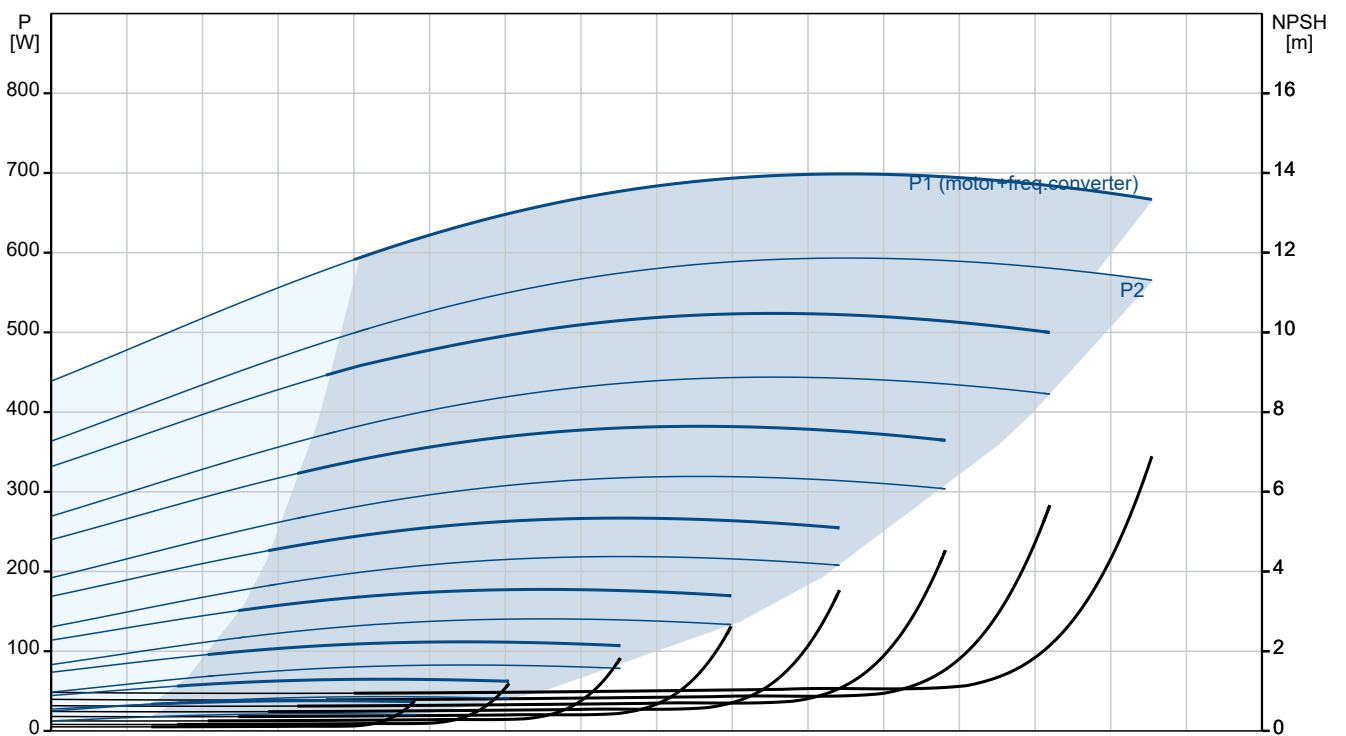
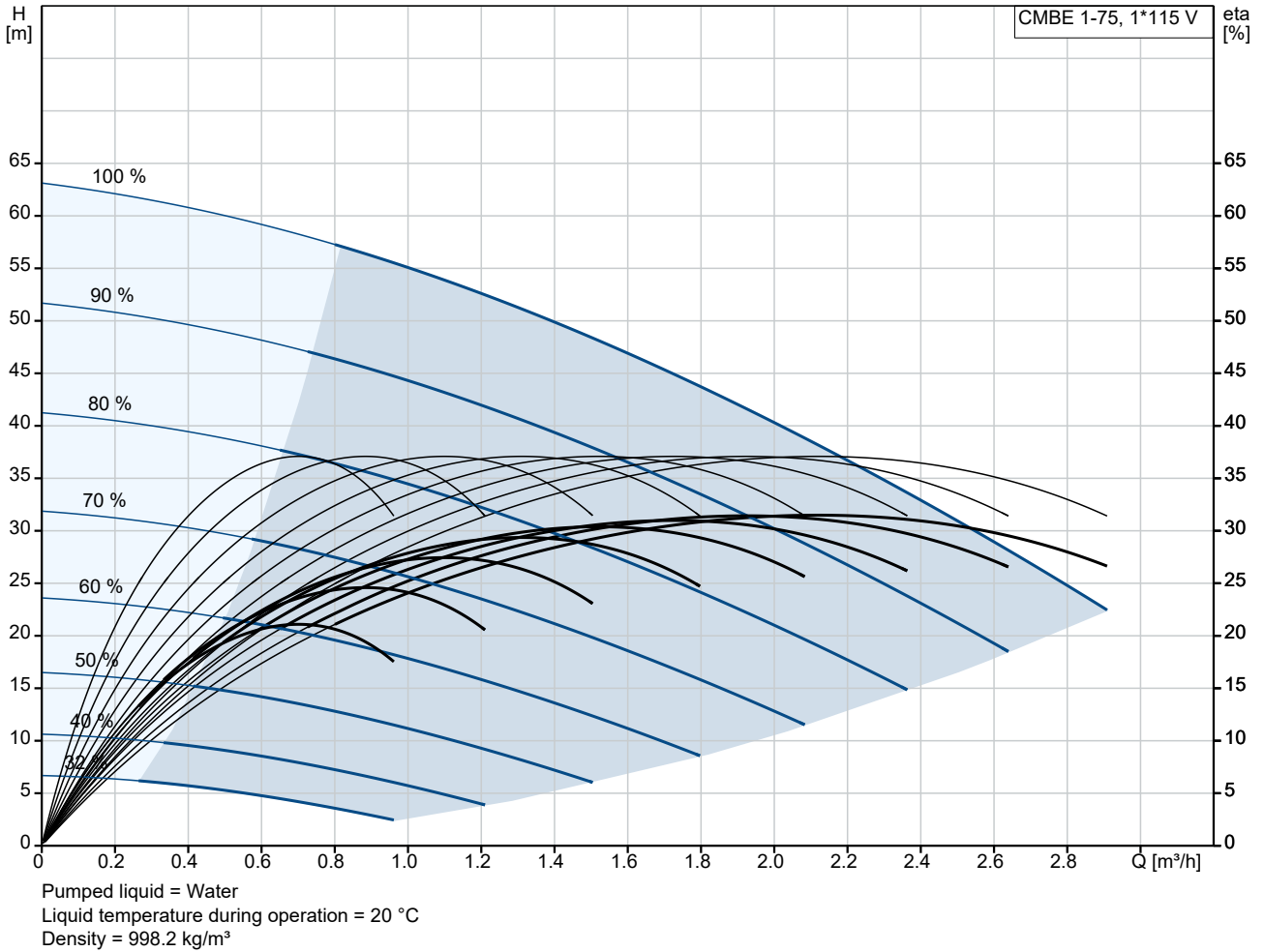

Description	Value
General information:	
Product name:	CMBE 1-75 I-X-C-B-D-E
Product No:	On request
EAN number:	On request
Technical:	
Pump speed on which pump data are based:	3780 rpm
Rated flow:	2 m ³ /h
Rated head:	43.6 m
Impellers:	5
Code for shaft seal:	AQQE
Approvals for drinking water:	CULUS DW NSF61
Curve tolerance:	ISO9906:2012 3B
Model:	A
Return valve:	YES
Start pressure:	Integrated Frequency converter
Materials:	
Pump housing:	Stainless steel
Pump housing:	EN 1.4301
Pump housing:	AISI 304
Impeller:	Stainless steel
Impeller:	EN 1.4301
Impeller:	AISI 304
Code for rubber:	EPDM
Installation:	
Maximum ambient temperature:	45 °C
Maximum operating pressure:	10 bar
Pipe connection standard:	ANSI B1.20.1
Type of inlet connection:	NPT(M)
Type of outlet connection:	NPT(F)
Size of inlet connection:	1
Size of outlet connection:	1
Pressure rating for connection:	PN 10
Liquid:	
Pumped liquid:	Water
Liquid temperature range:	0 .. 60 °C
Selected liquid temperature:	20 °C
Density:	998.2 kg/m ³
Electrical data:	
Rated power - P2:	0.75 kW
Mains frequency:	60 Hz
Rated voltage:	1 x 115 V
Maximum current consumption:	8 A
Rated speed:	360-4000 rpm
Enclosure class (IEC 34-5):	IP55
Insulation class (IEC 85):	F
Length of cable:	1.5 m
Power plug:	US plug 115V
Controls:	
Type of connector:	Type B (NEMA 5-15)
Frequency converter:	Built-in
Tank:	
Tank volume:	2 l
Others:	
Net weight:	17.6 kg
Gross weight:	27.4 kg
Shipping volume:	0.159 m ³

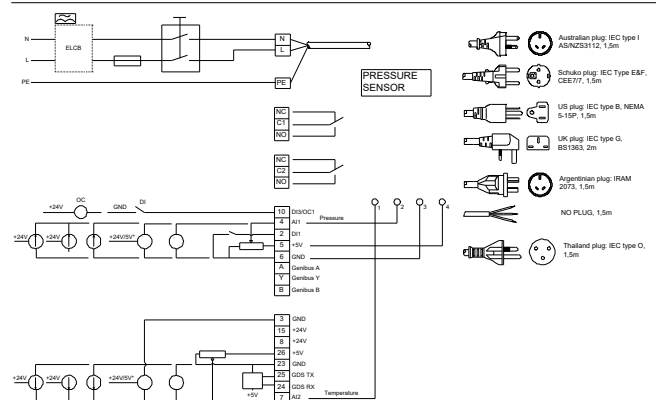
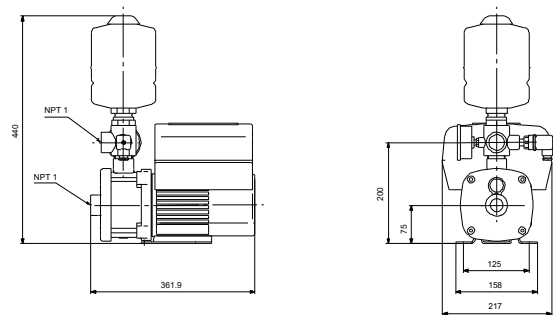
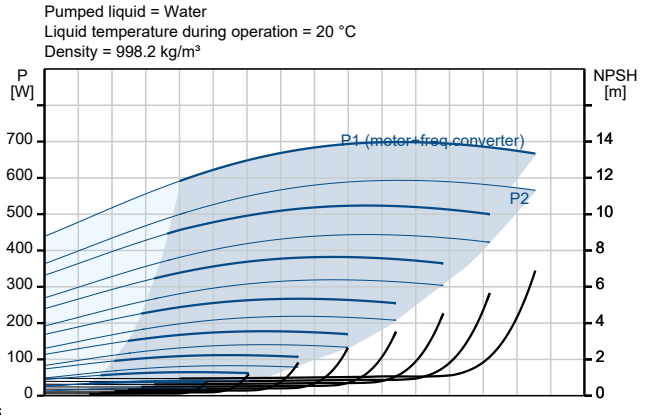
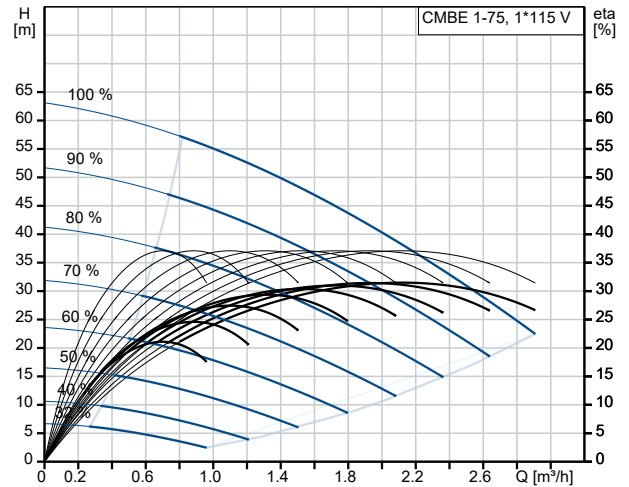



Company name:

Created by:

Phone:

Date:

08/08/2024

Description	Value
Sales region:	Namreg
Config. file no:	98845992

On request CMBE 1-75 I-X-C-B-D-E 60 Hz

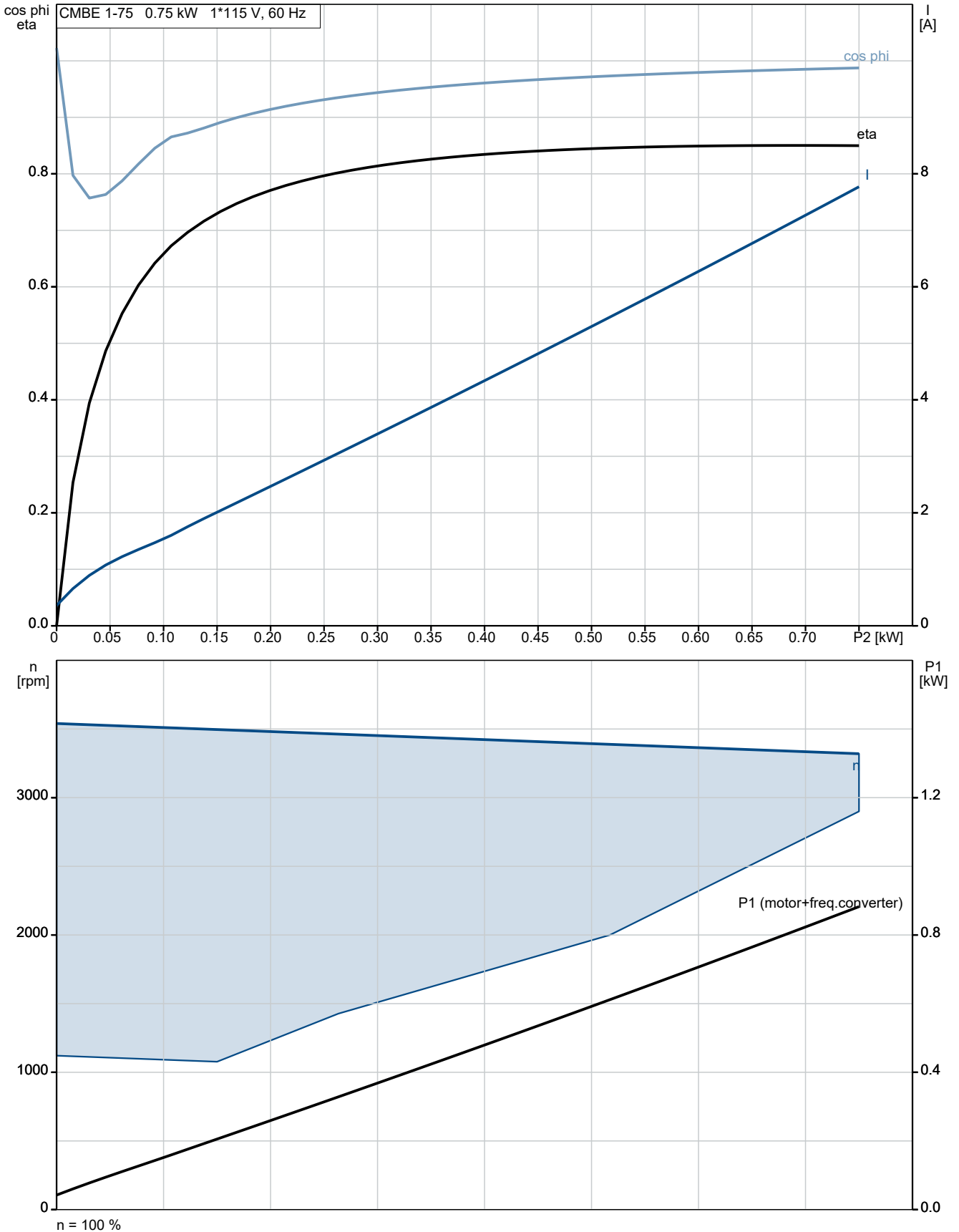

On request CMBE 1-75 I-X-C-B-D-E 60 Hz

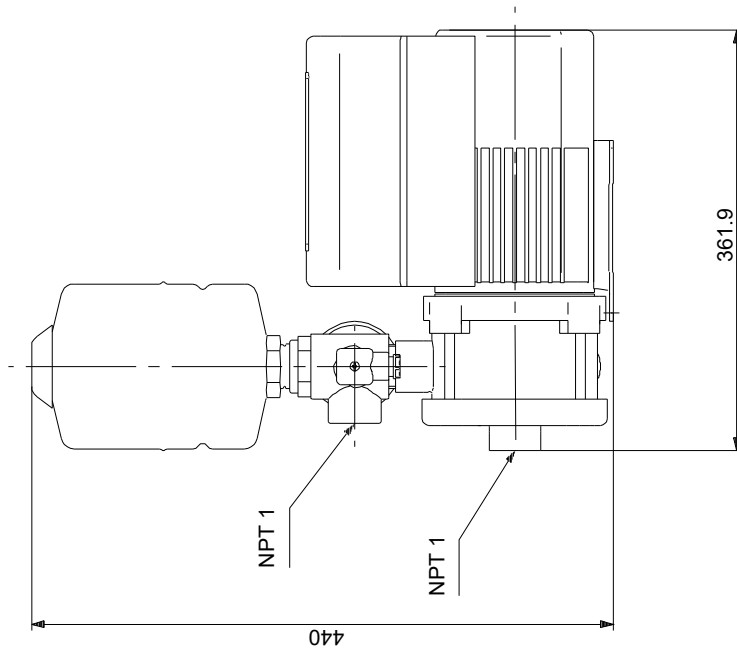
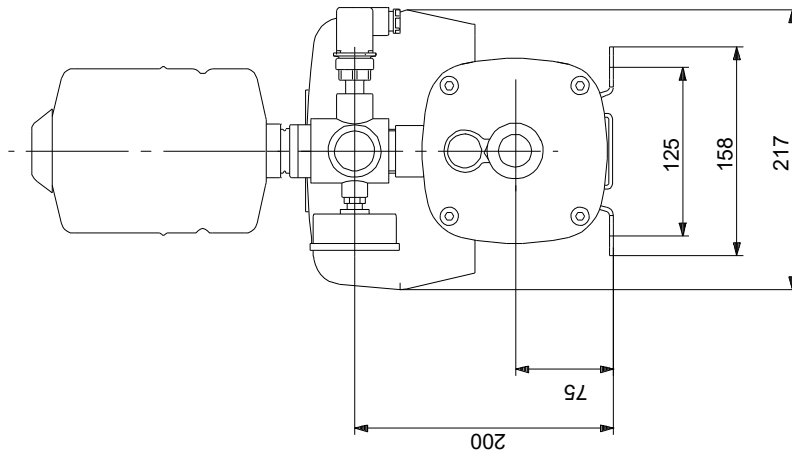

Note! All units are in [mm] unless others are stated.
Disclaimer: This simplified dimensional drawing does not show all details.

On request CMBE 1-75 I-X-C-B-D-E 60 Hz

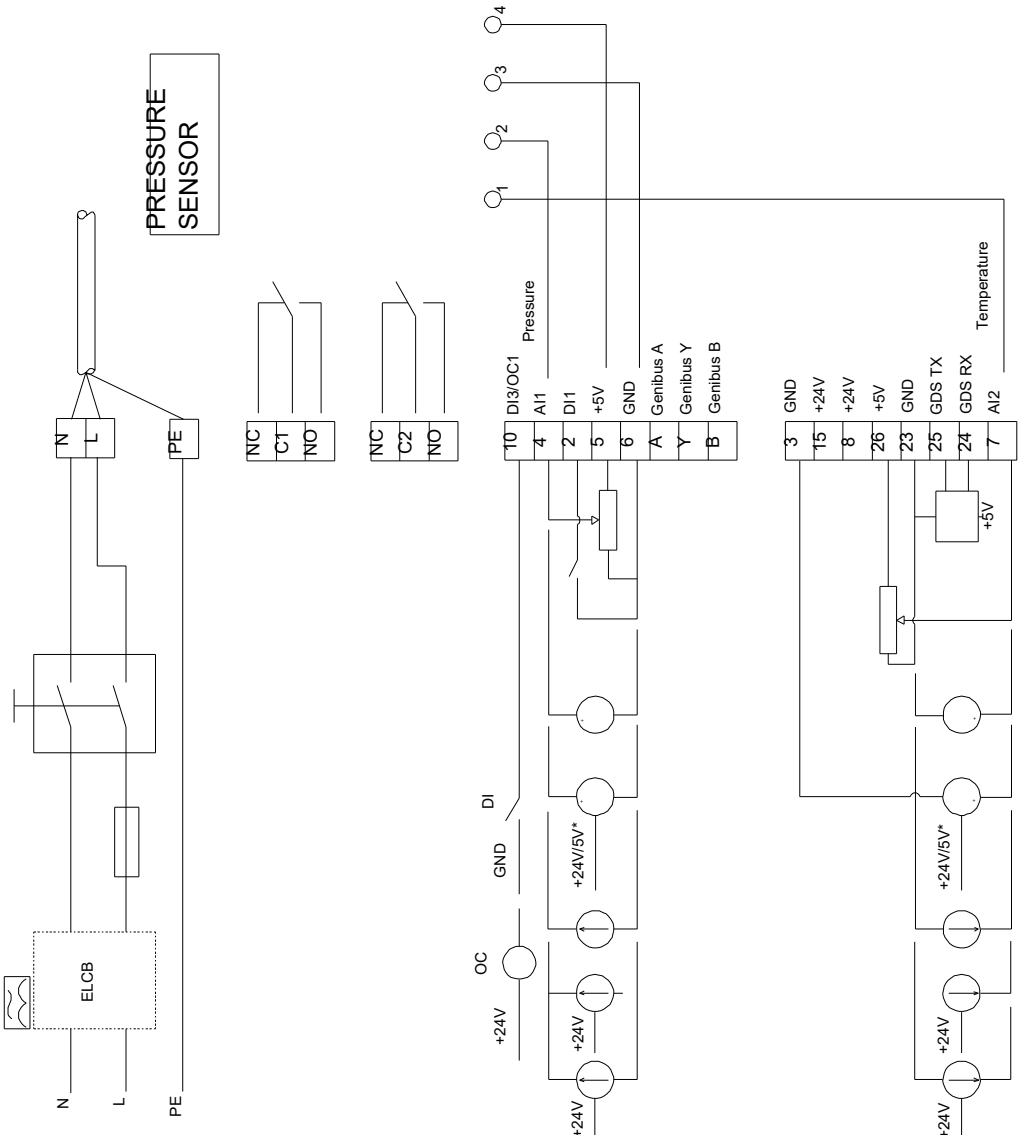
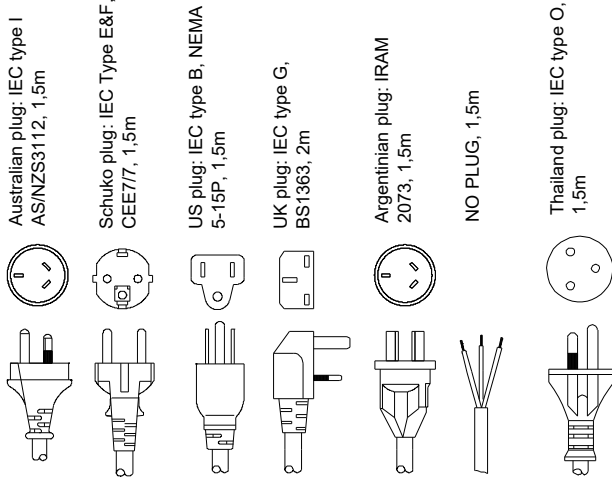

Note! All units are in [mm] unless others are stated.

