

# Pipe Hangers & Devices

Catalog No. 493

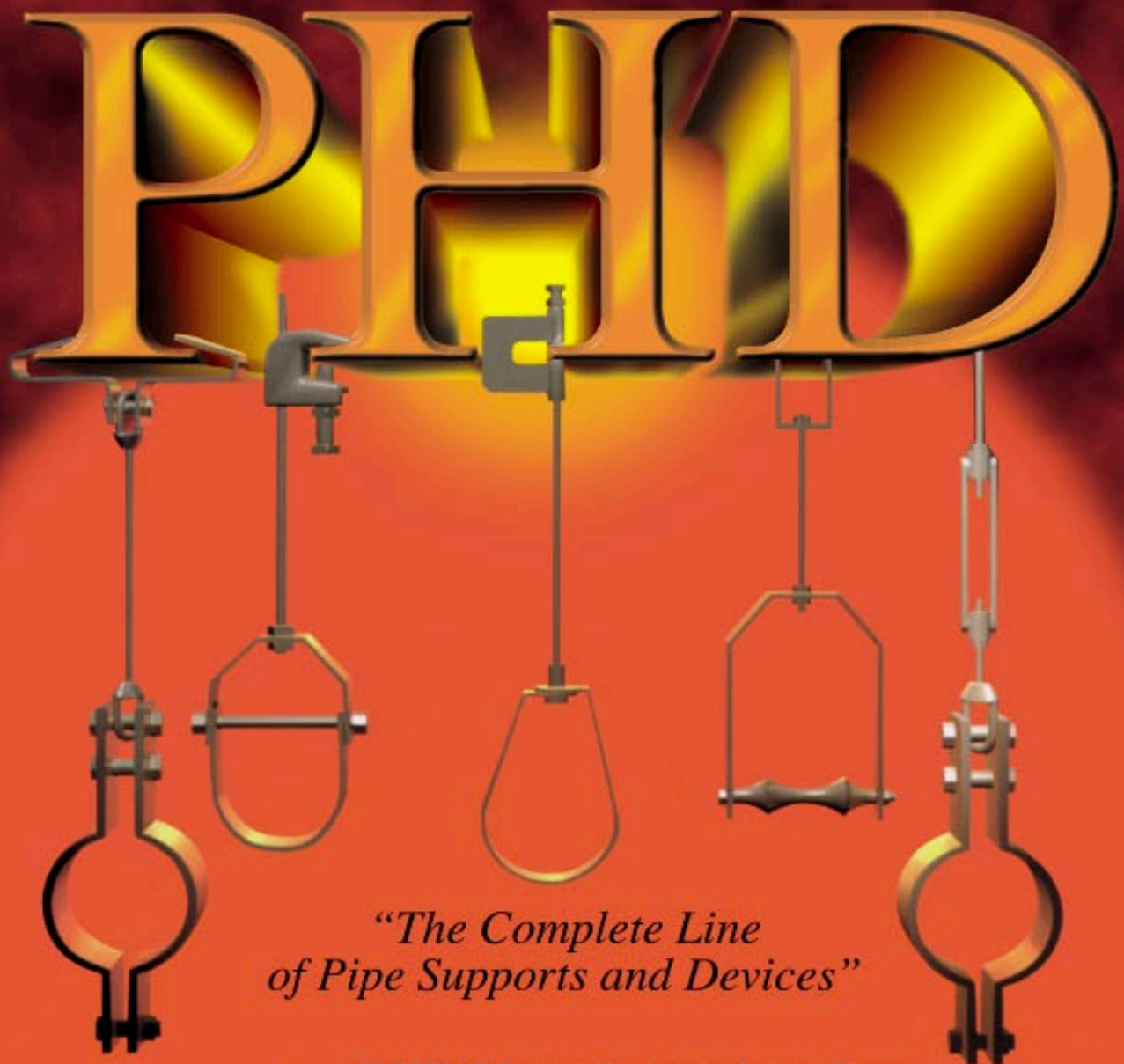

*“The Complete Line  
of Pipe Supports and Devices”*



**PHD Manufacturing, Inc.**

44018 Columbiana-Waterford Road  
Columbiana, Ohio 44408

Phone: (800) 321-2736 • (330) 482-9256  
Fax: (330) 482-2763 • [www.phd-mfg.com](http://www.phd-mfg.com)

**P**ride

**H**onesty

**D**edication



**PHD Manufacturing, Inc.**

44018 Columbiana-Waterford Road  
Columbiana, Ohio 44408

Phone: (800) 321-2736 ▪ (330) 482-9256  
Fax: (330) 482-2763 ▪ [www.phd-mfg.com](http://www.phd-mfg.com)

**YOUR LOCAL PHD REPRESENTATIVE IS:**

# TABLE OF CONTENTS



For the most updated version of our catalog, please visit our website at [www.phd-mfg.com](http://www.phd-mfg.com)

## GENERAL NOTES

TERMS & CONDITIONS OF SALE..... 4  
INTRODUCTION ..... 5  
GENERAL SPECIFICATIONS ..... 6  
PICTORIAL INDEX ..... 7- 14  
MATERIAL SPECIFICATIONS..... 15  
FINISHES & CORROSION..... 16 - 19

## HANGERS AND SUPPORTS

THREADED ACCESSORIES ..... 20 - 31  
CPVC STRAPS ..... 32 - 33  
BAND HANGERS ..... 35 - 39  
BEAM CLAMPS..... 40 - 46  
CLEVIS HANGERS ..... 47 - 56  
PIPE ROLLER SUPPORTS..... 57 - 66  
SPLIT RING HANGERS ..... 67 - 68  
PIPE CLAMPS ..... 69 - 79  
CENTER LOAD BEAM CLAMPS ..... 80 - 83  
PIPE SHIELDS, INSULATION, & SADDLES ..... 84 - 91  
PIPE GUIDES & SLIDES..... 92 - 95  
WALL BRACKETS..... 96 - 97  
PIPE SUPPORTS ..... 98 - 104  
STRUCTURAL ATTACHMENTS ..... 105 - 114  
SEISMIC BRACING ..... 115 - 122  
GENERAL TECHNICAL DATA..... 123 - 130  
COMPLIANCES & APPROVALS..... 131 - 134  
INDEX..... 135



# TERMS & CONDITION OF SALE

## **AGREEMENTS:**

All agreements are subject to availability of material, strikes, accidents, or other causes beyond our control.

## **WARRANTY:**

We warrant for one year from date of shipment our manufactured products to the extent that we will replace those having manufacturing defects when used for the purpose which we recommended. If goods are defective, the amount of damage is the price of the defective goods only and no allowance will be made for labor or expense of repairing defective goods or damage resulting from the same. We warrant the products we sell of other manufacturers to the extent of the warranties of their respective maker. This is the seller's sole warranty. Seller makes no other warranty of any kind, expressed or implied; and all implied warranties of merchantability and fitness for a particular purpose which exceed seller's afore stated obligation are hereby disclaimed by seller and excluded from this warranty.

For special order products made to the customer's specification, warranty is not valid and we are not responsible for load requirements or liable for damages incurred from product failure.

## **CLAIMS:**

No claims for shortages allowed unless made in writing within ten days of receipt of goods. All goods sent out will be carefully examined, counted and packed. Claims for goods damaged or lost in transit should be made on the carrier, as our responsibility ceases on delivery to the carrier.

## **SPECIAL ORDERS:**

Orders covering special or nonstandard goods are not subject to cancellation except on such terms as may be agreed upon.

## **TERMS AND DESIGN:**

Subject to change without notice. Refer to current price list for terms of sale. PHD Manufacturing, Inc. reserves the right to revise product design without notification.

## **RETURNS:**

We cannot accept return of any goods unless PHD Manufacturing, Inc.'s written permission has been first obtained, in which case same will be credited as follows:

- 1) All goods must be received in our plant in first class condition, if not, the cost of putting in salable condition will be deducted from credit.
- 2) Twenty-five percent (25%) will be deducted from credit memoranda issued for handling and restocking, less any charges allowed or paid by PHD Manufacturing, Inc.
- 3) Goods must be returned prepaid.
- 4) P.O.A. items cannot be returned.
- 5) There will be no returns of goods after one year from purchase date. Customer must provide invoice number.
- 6) There will be no return of goods under \$50.00, unless it is the result of PHD Manufacturing, Inc.'s error.

## **TAXES:**

To the price and terms quoted, there will be added any manufacturer's or sales taxes payable on the transaction under any effective statute.

## **MINIMUM INVOICE:**

\$50.00 plus transportation.

## **FREIGHT ALLOWANCE:**

All prices are F.O.B. point of shipment. On shipments of 2500 lbs. or more, rail freight or motor freight at the lowest published price is allowed to all U.S. highway points listed in published tariffs (Hawaii and Alaska excluded).

## **TERMS:**

Net 30 days. Monthly settlements on all accounts. One and-a-half percent (1½%) per month or eighteen percent (18%) per annum will be charged on all past due accounts, starting on the 31<sup>st</sup> day after the date of invoice.

## **DIMENSIONS & WEIGHTS:**

Although PHD Manufacturing, Inc. tries to be as accurate as possible, all listed dimensions and weights are an approximation and are not guaranteed.

# INTRODUCTION



PHD Manufacturing, Inc. was founded in 1972 by a group of industry veterans with strong management, financial, sales and manufacturing backgrounds. The entrepreneurial vision of this close group used the talents they acquired over the years to forge something special in a business that needed a different purpose. This core group continues to manage PHD Manufacturing, Inc. today, ensuring the original commitment to quality and excellence.

Our 30 professional sales representatives supporting the plumbing, mechanical and electrical industries are ready to serve your needs. Our manufacturing plant in Columbiana, Ohio, together with our 24 stocking warehouses throughout the United States, gives us one of the largest inventories in the industry.

Many of our products are Underwriter's Laboratories listed and Factory Mutual Approved. All PHD Manufacturing, Inc. products are manufactured to meet or exceed industry standards set for their design and manufacture. If you need a product not listed in this catalog, please call the factory or your local PHD Manufacturing, Inc. representative to check availability and pricing.

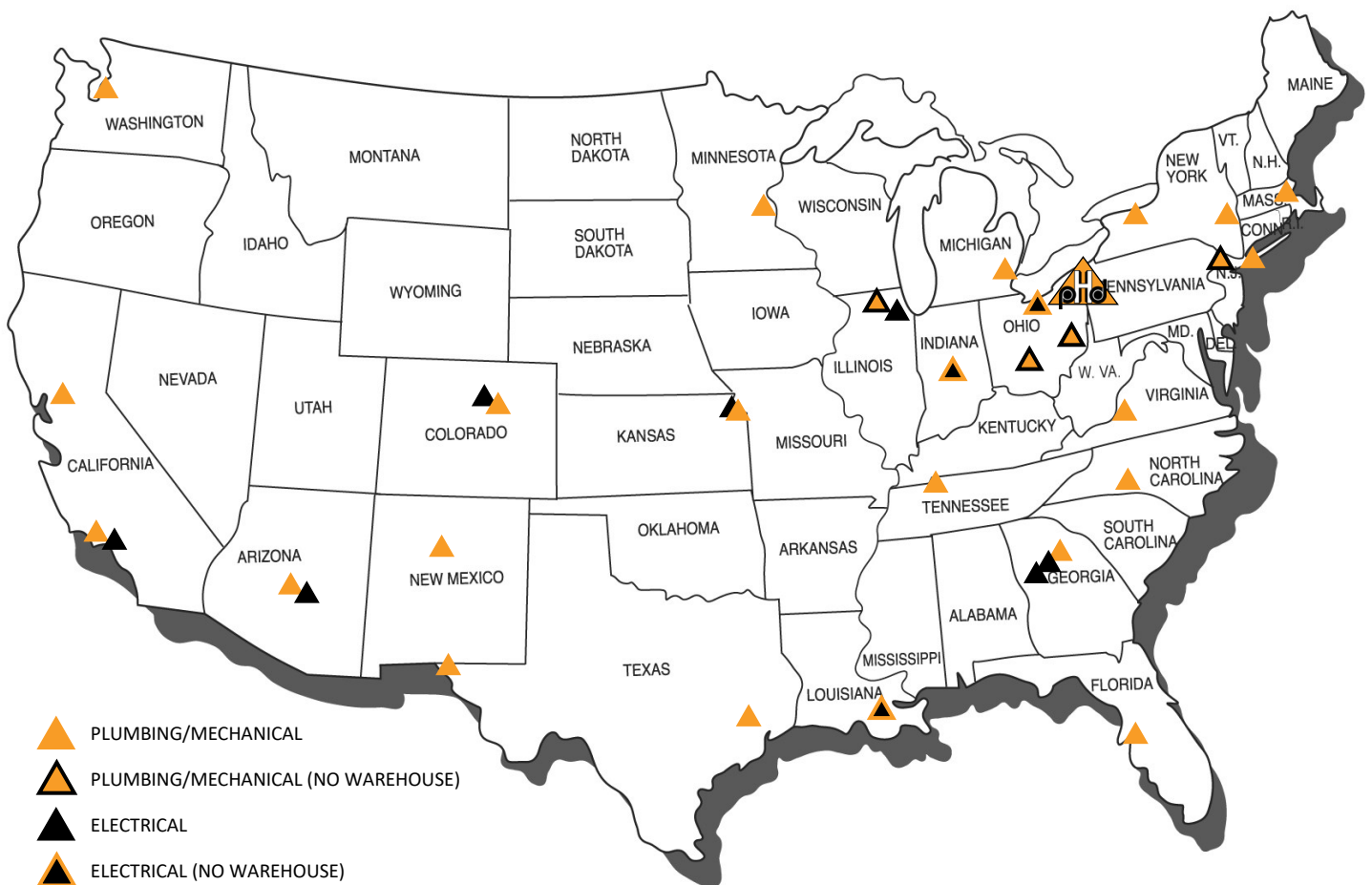



# GENERAL SPECIFICATIONS

## **References:**

- a. Federal, State, and Local codes.
- b. ANSI/MSS SP-58 - Manufacturers Standardization Society: Pipe Hangers and Supports - Materials, Design, and Manufacture.
- c. ANSI/MSS SP-69 - Manufacturers Standardization Society: Pipe Hangers and Supports – Selection and Application. ANSI/MSS SP-69 has been superseded by ANSI/MSS SP-58.
- d. NFPA 13 - Installation of Sprinkler Systems.
- e. ASTM - American Society for Testing and Materials.

## **Product Delivery, Handling, and Storage:**

- a. All material is to be delivered in original factory packaging to avoid any damage to the product. (i.e. denting, scratching, bending)
- b. All PHD Manufacturing, Inc. products are to be stored in a sheltered area where they will be protected from the elements and construction equipment.
- c. Installation of damaged product is not recommended.

## **Acceptable Manufacturers:**

- a. All hangers and supports to be installed shall be as manufactured by PHD Manufacturing, Inc. or engineer approved equal.

## **Quality Assurance:**

- a. Many of our products are Underwriters Laboratories Listed, Factory Mutual Approved, comply with Federal Specification A-A-1192A and Manufacturer's Standardization Society ANSI/MSS SP-58 which supersedes ANSI/MSS SP-69.
- b. All PHD Manufacturing, Inc. products are produced to meet or exceed industry standards set for their design and manufacture.

## **Execution:**

### -Examination

- a. The installer shall inspect the work area prior to installation. If work area conditions are unsatisfactory, installation shall not proceed until satisfactory corrections are completed.

### -Installation

- a. Installation shall be completed by a fully trained installer.
- b. Set hangers and supports into final position in accordance with job specifications and shop drawings.
- c. Anchor material firmly in place ensuring all connections are tightened appropriately.

### -Protection

- a. During installation, it is the installer's responsibility to protect this work from damage.
- b. It shall become the responsibility of the end user to protect this work from damage during the remainder of construction on the project upon completion of work.

### -Cleanup

- a. Remove all protective wraps and debris upon completion of this section of work.
- b. Repair any cosmetic damage due to installation.

## **Disclaimer:**

- a. PHD Manufacturing, Inc. has little or no control over such factors as environmental conditions, total system design, product selection, and maintenance.
- b. The installer is responsible for the application to conform to all applicable codes, the integrity of attaching structure, and the use of proper fasteners.
- c. All load ratings are for static conditions and neglect dynamic loading of any kind.

# PICTORIAL INDEX



## THREADED ACCESSORIES

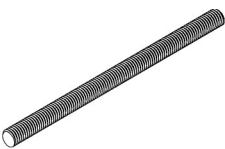

FIG. 10  
THREADED STUD  
PAGE 20



FIG. 15  
MACHINE THREAD  
ROD  
PAGE 20

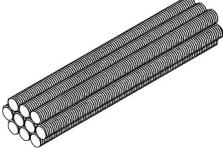

FIG. 20 & 21  
CONTINUOUS  
THREADED ROD  
PAGE 20

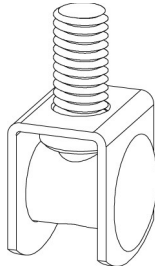

FIG. 020  
ROD SWIVEL  
ATTACHMENT  
PAGE 21

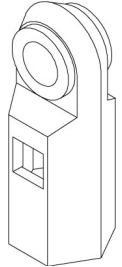

FIG. 25  
EXTENSION PIECE  
PAGE 21

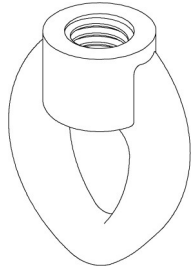

FIG. 30  
EYE SOCKET  
PAGE 22

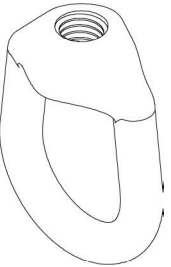

FIG. 35 & 35L  
WELDLESS EYE NUT  
PAGE 22

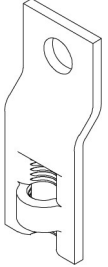

FIG. 36  
STEEL EYE SOCKET  
PAGE 23

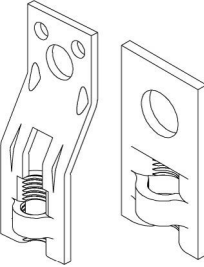

FIG. 37  
STEEL EYE SOCKET  
PAGE 23

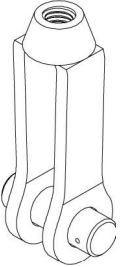

FIG. 38 & 38L  
FORGED STEEL  
CLEVIS  
PAGE 24

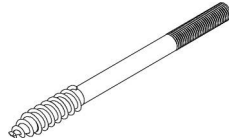

FIG. 40  
COACH SCREW ROD  
PAGE 25

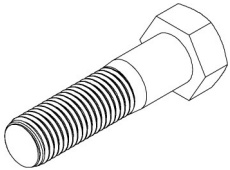

FIG. 41  
HEX HEAD BOLT  
PAGE 25

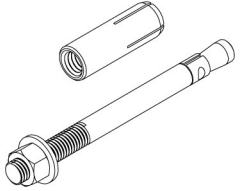

FIG. 47  
CONCRETE  
ANCHORS  
PAGE 26



FIG. 48  
WOOD DRIVE  
SCREW  
PAGE 26



FIG. 50 - 55L  
EYE ROD  
PAGE 27

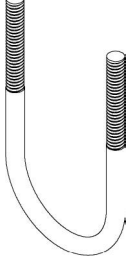

FIG. 90 - 95  
U-BOLT  
PAGE 28-29

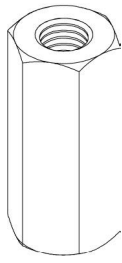

FIG. 100, 104, & 105  
ROD COUPLINGS  
PAGE 29-30

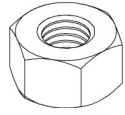

FIG. 110 & 110H  
HEX NUT  
PAGE 30

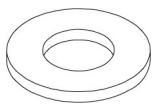

FIG. 130  
FLAT WASHER  
PAGE 30

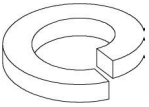

FIG. 134  
LOCK WASHER  
PAGE 30

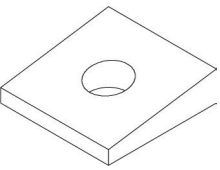

FIG. 135  
BEVEL WASHER  
PAGE 31

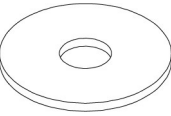

FIG. 136  
FENDER WASHER  
PAGE 31

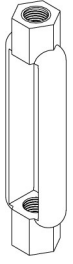

FIG. 960  
TURNBUCKLE  
PAGE 31

# PICTORIAL INDEX

## CPVC STRAPS

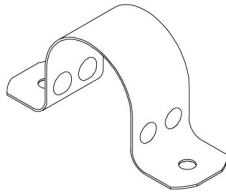

FIG. 070  
CPVC TWO-HOLE  
PIPE STRAP  
PAGE 32

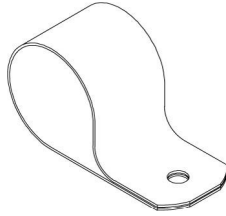

FIG. 075  
CPVC ONE-HOLE  
WRAP AROUND  
PAGE 32

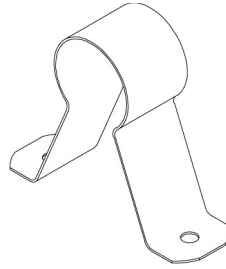

FIG. 076  
CPVC TWO-HOLE  
STAND OFF STRAP  
PAGE 33

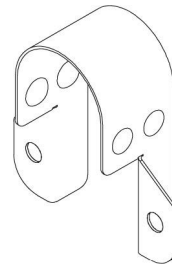

FIG. 077  
CPVC TWO-HOLE  
SIDE MOUNT STRAP  
PAGE 33

## BAND HANGERS

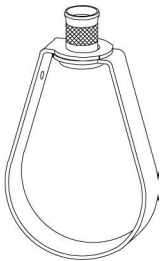

FIG. 141  
NFPA SWIVEL  
RING HANGER  
PAGE 35

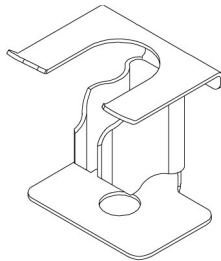

FIG. 055  
SERGE RESTRAINT  
PAGE 35

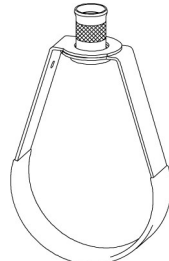

FIG. 143  
PVC SWIVEL  
RING HANGER  
PAGE 36

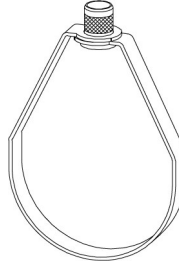

FIG. 151  
SWIVEL  
RING HANGER  
PAGE 37

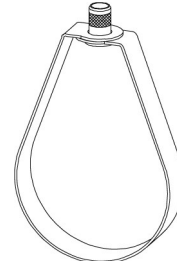

FIG. 152 & 154  
COPPER TUBING  
HANGER  
PAGE 37

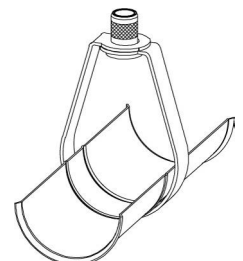

FIG. 145 & 155  
RING HANGER  
WITH SHIELD  
PAGE 38

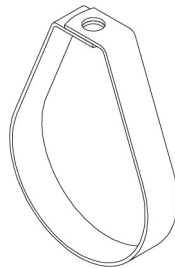

FIG. 180 - 182  
BAND HANGER  
PAGE 38-39

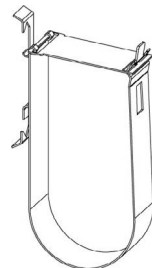

FIG. TRH 2 - TRH 5  
TRH HANGING  
SYSTEM  
PAGE 39



# PICTORIAL INDEX

## BEAM CLAMPS

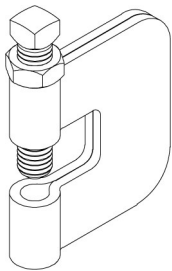

FIG. 250  
STEEL C-CLAMP  
PAGE 40

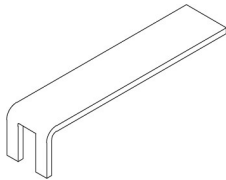

FIG. 259  
C-CLAMP  
RETAINING STRAP  
PAGE 40

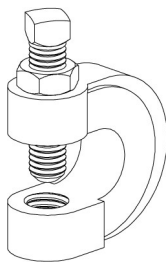

FIG. 270  
MALLEABLE IRON  
C-CLAMP  
PAGE 41

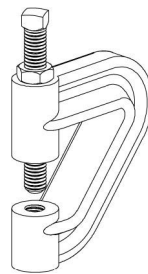

FIG. 290  
PURLIN CLAMP  
PAGE 41

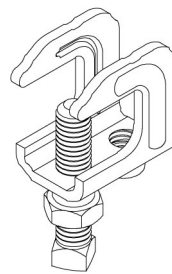

FIG. 345  
STAMPED STEEL  
TOP BEAM CLAMP  
PAGE 42

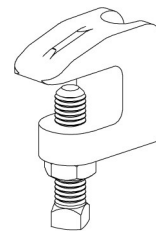

FIG. 350  
IMPORT BEAM  
CLAMP  
PAGE 43

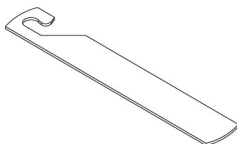

FIG. 358  
RETROFIT  
RETAINING STRAP  
PAGE 42

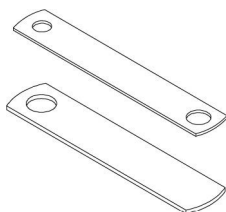

FIG. 359  
BEAM CLAMP  
RETAINING STRAP  
PAGE 43

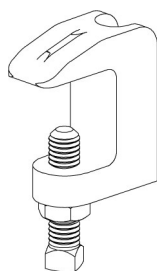

FIG. 360  
IMPORT WIDE  
MOUTH BEAM  
CLAMP  
PAGE 44

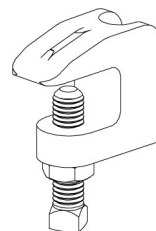

FIG. 350 - 357  
DOMESTIC BEAM  
CLAMP  
PAGE 45

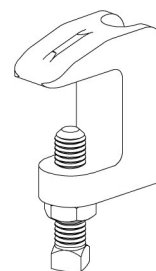

FIG. 363 & 364  
DOMESTIC WIDE  
MOUTH BEAM  
CLAMP  
PAGE 46

## CLEVIS HANGERS

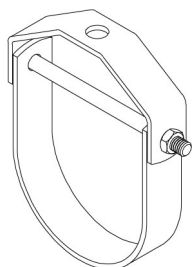

FIG. 420  
A.W.W.A. CLEVIS  
PAGE 47

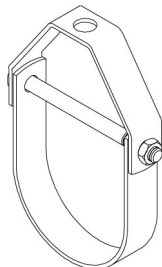

FIG. 425 & 426  
STAINLESS STEEL  
CLEVIS  
PAGE 48

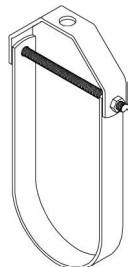

FIG. 430  
INSULATED PIPE  
CLEVIS  
PAGE 49

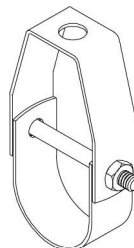

FIG. 440 - 441  
LIGHT DUTY  
CLEVIS  
PAGE 50

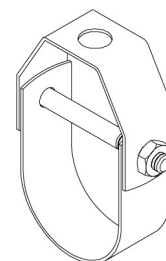

FIG. 442  
COPPER TUBING  
CLEVIS  
PAGE 51

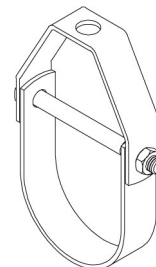

FIG. 450 - 454  
STANDARD CLEVIS  
PAGE 52

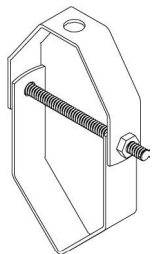

FIG. 450V  
V-BOTTOM CLEVIS  
PAGE 53

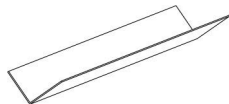

FIG. 450T  
V-BOTTOM CLEVIS  
SUPPORT TROUGH  
PAGE 53

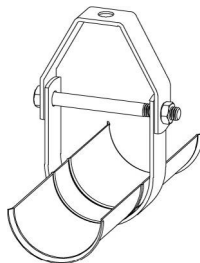

FIG. 455 - 456  
CLEVIS WITH  
SECURED SHIELD  
PAGE 54

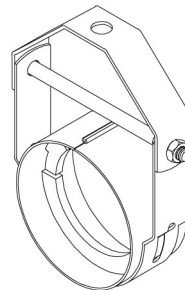

FIG. 703025-708362  
CLEVIS SERIES KLO-  
SHURE HANGER  
PAGE 55

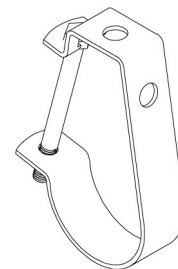

FIG. 970 - 973  
J-HANGER  
PAGE 56

# PICTORIAL INDEX

## PIPE ROLLER SUPPORTS

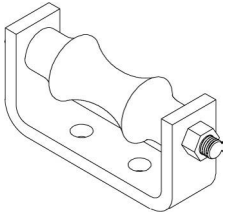

FIG. 460  
PIPE ROLLER CHAIR  
PAGE 57

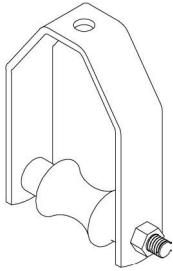

FIG. 470 & 475  
PIPE ROLLER  
HANGER  
PAGE 58

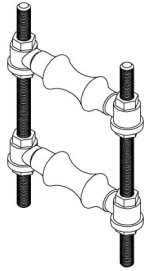

FIG. 480 & 480D  
ADJUSTABLE PIPE  
ROLLER SUPPORT  
PAGE 59

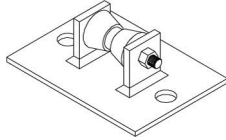

FIG. 486  
PIPE ROLLER  
STAND  
PAGE 60

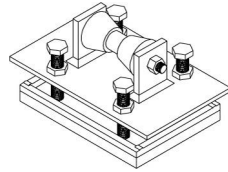

FIG. 487  
ADJUSTABLE PIPE  
ROLLER STAND  
WITH BASE  
PAGE 61

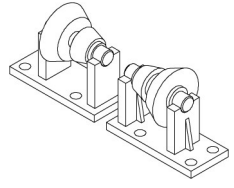

FIG. 488  
FABRICATED  
ROLLER FOR  
LARGE PIPING  
PAGE 62

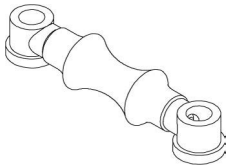

FIG. 490  
PIPE ROLLER  
WITH SOCKETS  
PAGE 63

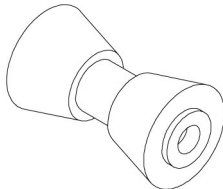

FIG. 485  
SHORT PIPE ROLLER  
PAGE 64

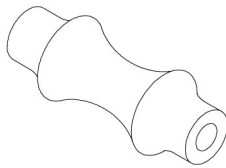

FIG. 495  
LONG PIPE ROLLER  
PAGE 65

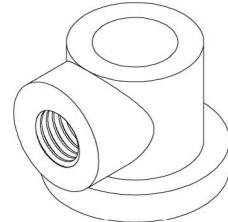

FIG. 496  
ROLLER SOCKET  
PAGE 65

## SPLIT RING HANGERS

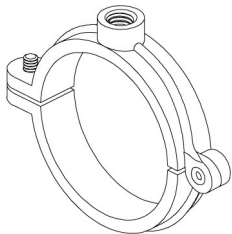

FIG. 508R  
HINGED EXTENSION  
SPLIT CLAMP  
PAGE 67

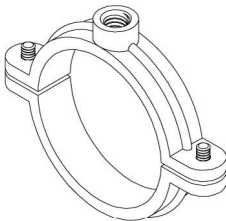

FIG. 510R  
EXTENSION  
SPLIT CLAMP  
PAGE 67

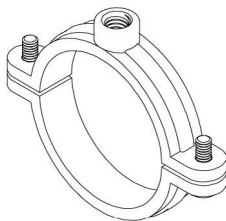

FIG. 512  
COPPER TUBING  
EXTENSION SPLIT  
CLAMP  
PAGE 68

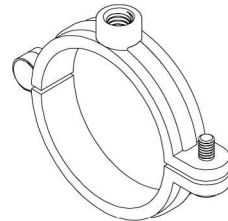

FIG. 512H  
HINGED COPPER  
TUBING EXTENSION  
SPLIT CLAMP  
PAGE 68

# PICTORIAL INDEX

## PIPE CLAMPS

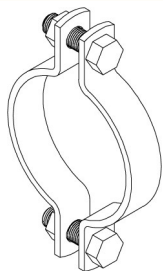

FIG. 520 & 521  
STANDARD  
PIPE CLAMP  
PAGE 69

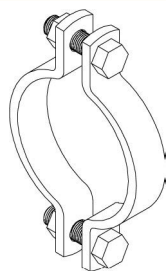

FIG. 522  
HEAVY DUTY  
PIPE CLAMP  
PAGE 70

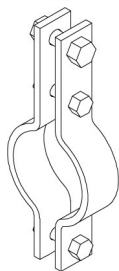

FIG. 525  
DOUBLE BOLT  
PIPE CLAMP  
PAGE 71

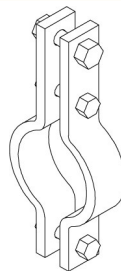

FIG. 526  
HEAVY DUTY  
DOUBLE BOLT  
PIPE CLAMP  
PAGE 72

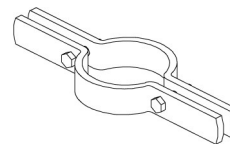

FIG. 550, 551 & 553  
RISER CLAMP  
PAGE 73

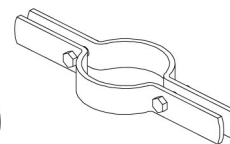

FIG. 552 & 554  
COPPER TUBING  
RISER CLAMP  
PAGE 74

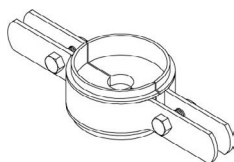

FIG. R087100-R412150  
INSULATION  
RISER CLAMP  
PAGE 75

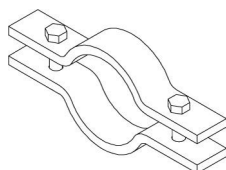

FIG. 580  
TWO BOLT  
UNDERGROUND  
PIPE CLAMP  
PAGE 76

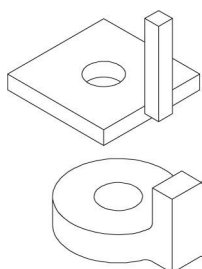

FIG. 585  
WASHER FOR  
FIG. 580  
PAGE 76

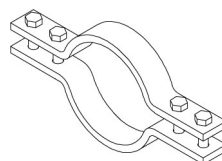

FIG. 590  
FOUR BOLT  
UNDERGROUND  
PIPE CLAMP  
PAGE 77

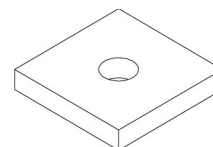

FIG. 595  
WASHER FOR  
FIG. 590  
PAGE 77

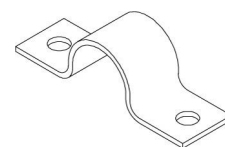

FIG. 825 & 826  
TWO HOLE STRAP  
PAGE 78

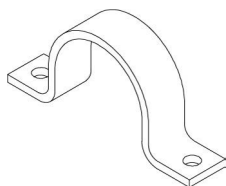

FIG. 830  
SHORT PIPE STRAP  
PAGE 78



FIG. 835-837  
ONE HOLE STRAP  
PAGE 79

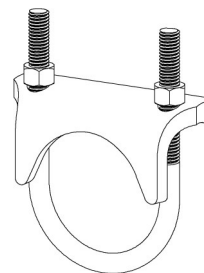

FIG. 840  
RIGHT ANGLE  
CLAMP  
PAGE 79

## CENTER LOAD CLAMPS

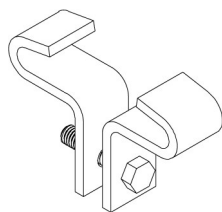

FIG. 610 & 620  
STEEL CENTER  
LOAD BEAM  
CLAMP  
PAGE 80

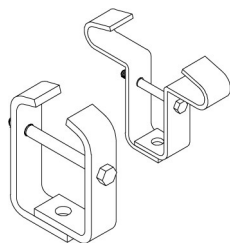

FIG. 625  
STEEL CENTER  
LOAD BEAM  
CLAMP  
PAGE 81

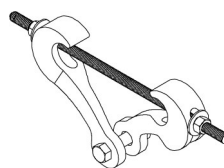

FIG. 630  
MALLEABLE  
CENTER LOAD  
BEAM CLAMP  
PAGE 81

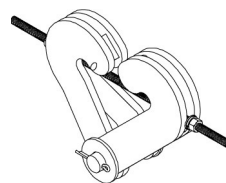

FIG. 632 - 633  
STEEL CENTER  
LOAD BEAM  
CLAMP  
PAGE 82

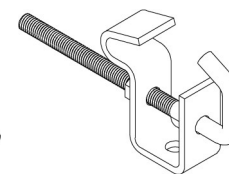

FIG. 635  
ADJUSTABLE STEEL  
BEAM CLAMP  
PAGE 83

# PICTORIAL INDEX

## SHIELDS, INSULATION, & PIPE SADDLES

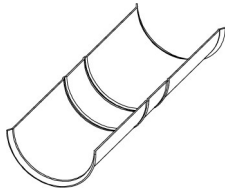

FIG. 160  
SELF CENTERING  
INSULATION  
SHIELD  
PAGE 84

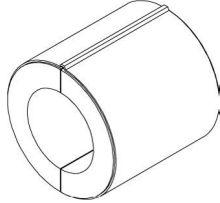

FIG. 165-166  
SELF-LOCKING  
PIPE & TUBE  
INSULATION  
PAGE 87

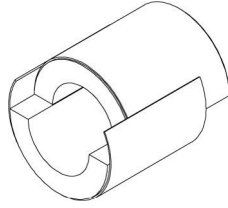

FIG. 167-168  
NON-LOCKING  
PIPE & TUBE  
INSULATION  
PAGE 88

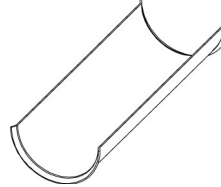

FIG. 170  
INSULATION  
SHIELD  
PAGE 85

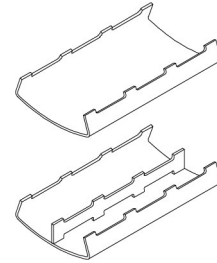

FIG. 651 & 658  
PIPE SADDLE  
PAGE 89 - 91

## PIPE GUIDES & SLIDES

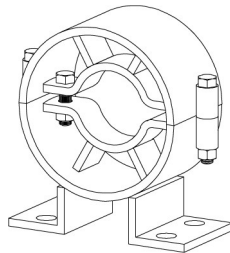

FIG. 670 - 678  
PIPE ALIGNMENT  
GUIDE  
PAGE 92

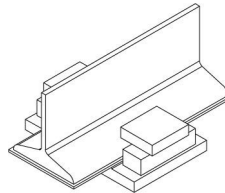

FIG. 690  
PIPE SLIDE  
PAGE 94-95

## WALL BRACKETS

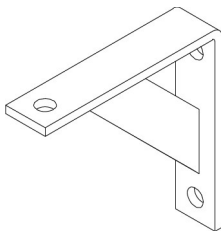

FIG. 850  
LIGHT DUTY  
WALL BRACKET  
PAGE 96

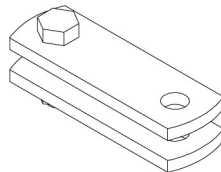

FIG. 850C  
CLIP FOR FIG. 850  
WALL BRACKET  
PAGE 96

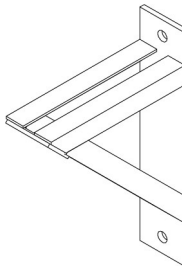

FIG. 855  
MEDIUM DUTY  
WALL BRACKET  
PAGE 97

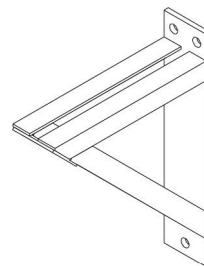

FIG. 860  
HEAVY DUTY  
WALL BRACKET  
PAGE 97

# PICTORIAL INDEX

## PIPE SUPPORTS

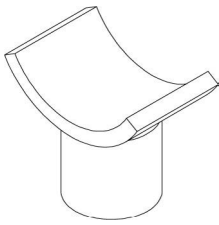

FIG. 870  
PIPE SADDLE  
SUPPORT WITH  
COUPLING  
PAGE 98

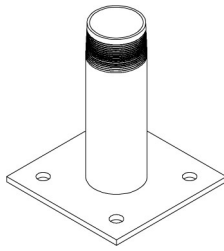

FIG. 871  
THREADED BASE  
STAND  
PAGE 98

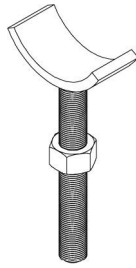

FIG. 874  
PIPE SADDLE SUP-  
PORT WITH STUD  
PAGE 99

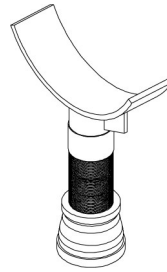

FIG. 875  
ADJUSTABLE PIPE  
SADDLE SUPPORT  
PAGE 99

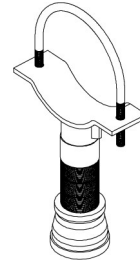

FIG. 876  
ADJUSTABLE PIPE  
SADDLE SUPPORT  
WITH U-BOLT  
PAGE 100

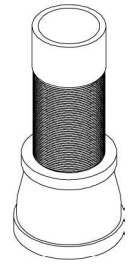

FIG. 877  
PIPE SUPPORT  
ADJUSTER  
PAGE 100

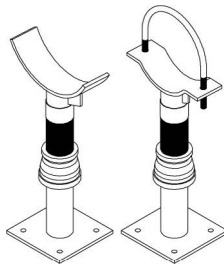

FIG. 878 & 879  
PIPE SUPPORT  
ADJUSTER  
PAGE 101

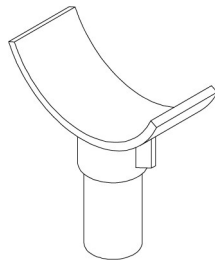

FIG. 880  
PIPE SADDLE  
SUPPORT  
PAGE 102

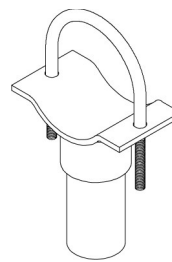

FIG. 882  
PIPE SADDLE  
SUPPORT WITH  
U-BOLT  
PAGE 103

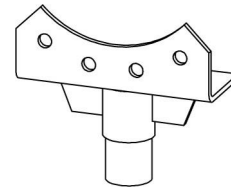

FIG. 883  
PIPE FLANGE  
SUPPORT  
PAGE 104

## STRUCTURAL ATTACHMENTS

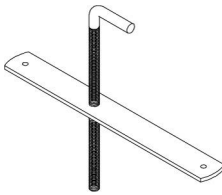

FIG. 885  
ADJUSTABLE  
Q-DECK INSERT  
PAGE 105

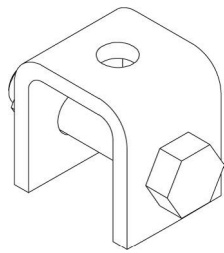

FIG. 900 & 900-1  
WELDED BEAM  
ATTACHMENT  
PAGE 106

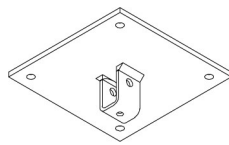

FIG. 903  
CONCRETE ROD  
ATTACHMENT PLATE  
PAGE 107

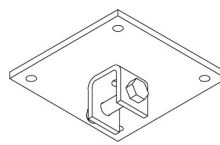

FIG. 904  
CONCRETE  
CLEVIS PLATE  
PAGE 108

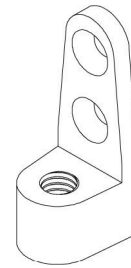

FIG. 905  
SIDE BEAM  
CONNECTOR  
PAGE 109

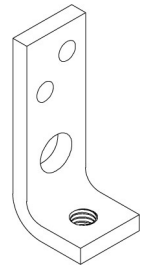

FIG. 906  
STEEL SIDE BEAM  
CONNECTOR  
PAGE 109

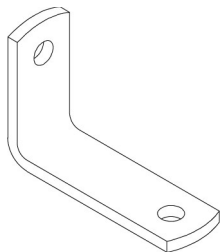

FIG. 910  
REVERSIBLE  
ANGLE BRACKET  
PAGE 109

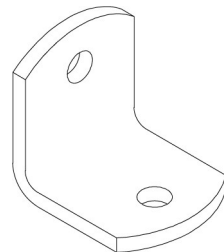

FIG. 920  
SIDE BEAM  
ANGLE BRACKET  
PAGE 110

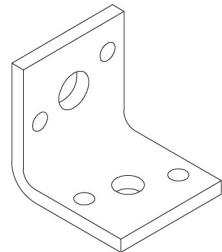

FIG. 925  
REVERSIBLE SIDE  
BEAM ANGLE  
BRACKET  
PAGE 110

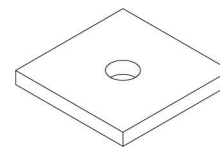

FIG. 930  
SQUARE PLATE  
WASHER  
PAGE 111

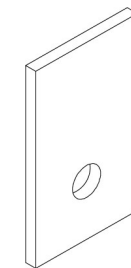

FIG. 935 & 936  
WELDING LUG  
PAGE 111

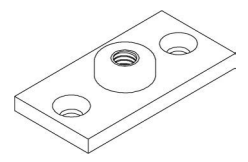

FIG. 940 - 942  
CEILING FLANGE  
PAGE 112

# PICTORIAL INDEX

## STRUCTURAL ATTACHMENTS (CONT'D)

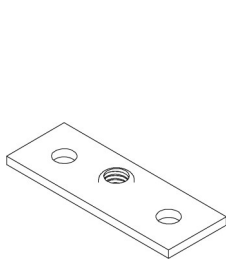

FIG. 945 & 946  
STEEL CEILING  
PLATE  
PAGE 112

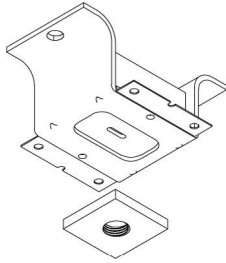

FIG. 950 - 951N  
CONCRETE INSERT  
PAGE 113

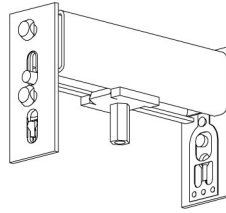

FIG. 990  
ADJUSTABLE  
IN-RACK FLUE  
HANGER  
PAGE. 114

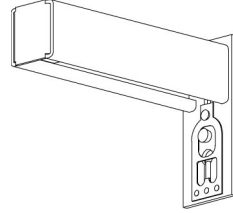

FIG. 995  
SINGLE IN-RACK  
FLUE HANGER  
PAGE. 114

## SEISMIC

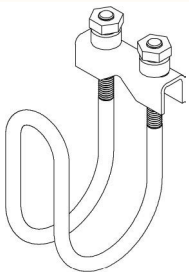

FIG. 010  
SWAY BRACE PIPE  
ATTACHMENT  
PAGE 115

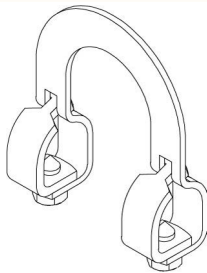

FIG. 015  
LARGE SWAY  
BRACE PIPE  
ATTACHMENT  
PAGE 116

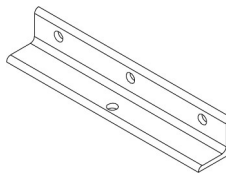

FIG. 025  
MULTI-FASTENER  
ADAPTER  
PAGE 117

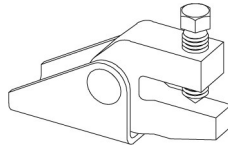

FIG. 030  
C-CLAMP  
STRUCTURAL  
ATTACHMENT  
PAGE 118

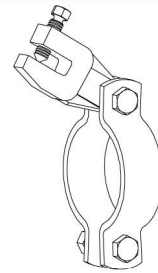

FIG. 031  
CLAMPING PIPE  
ATTACHMENT  
PAGE 119

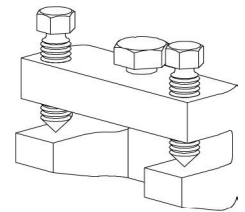

FIG. 035  
SWAY BRACE  
BAR JOIST  
ADAPTER  
PAGE 120

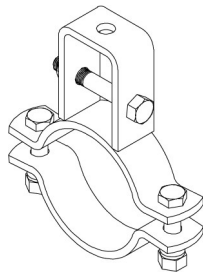

FIG. 040  
SUPPORTING PIPE  
ATTACHMENT  
PAGE 121

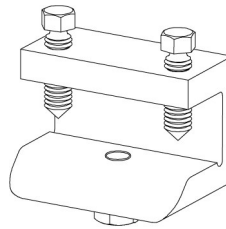

FIG. 045  
SWAY BRACE  
STRUCTURAL  
ADAPTER  
PAGE 122

## PIPE HANGERS & DEVICES

**Cast Iron:**

-Grey Cast Iron, ANSI/ASTM A48, Class #20

**Malleable Iron:**

-ANSI/ASTM A47, Grade Number 32510

**Ductile Iron:**

-ASTM A536 Grade 65-45-12

**Forged Steel:**

-ASTM A668 or A1030

**Spring Steel:**

-SAE 1066-65Mn

**Carbon Steel:** (3 Gauge Thickness and Below)

-ASTM A1011 CS Type A, B, or C

**Carbon Steel:** ( $\frac{1}{4}$ " Thickness and Above)

-ASTM A36, Structural Quality

**Pre-Galvanized Steel:**

-ASTM A653, Grade 33 Steel Sheet Coated by Hot Dip Process

**Stainless Steel:**

-ASTM A240, Type 304

-ASTM A240, Type 316

## ALUMINUM

The high strength to weight ratio of PHD Manufacturing, Inc. products made of aluminum greatly reduces the overall cost of installation through ease of handling and field cutting.

Aluminum owes its excellent corrosion resistance to its ability to form an aluminum oxide film that immediately reforms when scratched or cut. In most outdoor applications, aluminum has excellent resistance to "weathering". The resistance to chemicals, indoor or outdoor, can best be determined by tests conducted by the user with exposure to the specific conditions for which it is intended.

To determine the approximate load data for strut, multiply the load data found in this catalog by a factor of 0.38.

## CARBON STEEL

PHD Manufacturing, Inc. products made from high-quality carbon steel are cold formed to precise dimensions. By cold working the steel mechanical properties are increased, allowing lightweight structures to carry the required load. Corrosion resistance of carbon steel varies widely with coating and alloy. See "Finishes" for more detailed information.

## STAINLESS STEEL

Because of its corrosion resistance, stainless steel is recommended for applications where corrosion is a problem. Load data for PHD Manufacturing, Inc. stainless steel products is the same as the load data in this catalog.

Stainless steel products are available in ASTM A-240, Type 304 or 316 material. Both are low-magnetic and belong to the austenitic stainless steels group, based on alloy content and crystallographic structure. Like carbon steel, stainless steel exhibits increased strength when cold worked.

Several conditions make the use of stainless steel ideal. These include reducing long term maintenance costs, high ambient temperatures, appearance, and stable structural properties such as yield strength, and high creep strength.

Type 304 resists most organic chemicals, dyestuffs and a wide variety of inorganic chemicals at elevated or cryogenic temperatures. Type 316 contains slightly more nickel and adds molybdenum to give it better corrosion resistance in chloride and sulfuric acid environments.

# FINISHES & CORROSION

## PLAIN (PL)

Plain finish designation means that the product retains the oiled surface applied to the raw steel during the forming process. The fittings have the original oiled surface of the bar-stock material.

## PVC COATING (PVC)

PVC coating helps reduce noise and protect the pipe or tubing from the metal surface of the hanger. Corrosion resistance protection is minimal. PVC coating is not compatible with CPVC pipe.

## COPPER COLOR EPOXY FINISH (CCEF)

Designed for use with copper tubing. This coating provides a better level of corrosion resistance than the traditional copper plated finish. It also acts as a protective barrier, avoiding contact between dissimilar metals. The copper color epoxy powder is applied by an electrostatic method, and the coated parts are baked at 180 degrees for 20 minutes.

## POWDER COATING (PTD)

PHD Manufacturing, Inc. offers a polyester powder coating that utilizes powder material conforming to ASTM D3451. It is applied by means of an electrostatic spray at ambient temperature.

## CHANNEL GREEN: POLYESTER

### POWDER PROPERTIES

Test Method	Powder Properties	Tolerances
ASTM D3451 (18.30)	Specific Gravity	1.33 ± 0.03
ASTM D3451 (18.30)	Theoretical Coverage	144.58 ± 4.0 FT <sup>2</sup> /Lb./Mil.
ASTM D3451 (13)	Volatile Content	Max. 2.5%
ASTM D3451 (13)	Storage Temperature Max	80°F

### COATING PROPERTIES

All tests performed on substrate 0.032 CRS Pretreatment Bonderite 1000

Test Method	Coating Properties	Tolerances/Specifications
ASTM D523	Gloss 20°/60°	70-80
ASTM D2454	Over Bake Resistance Time	100%
ASTM D3363	Pencil Hardness	H - 2H
ASTM D2794 (Modified)	Direct Impact (Gardner)	80 in. Lbs.
ASTM D2794 (Modified)	Reverse Impact (Gardner)	80 in. Lbs.
ASTM D3359	Adhesion (Cross Hatch)	Pass No Adhesion Loss
ASTM D522	Flexibility (Mandrel)	1/8 Bend No Fracture
ASTM B117	Salt Spray	1000 Hrs.
ASTM D2247	Humidity	500 Hrs.

### APPLICATION

Test Method	Application	Cure Schedule
Electrostatic Spray	Ambient Temperature	15' @ 375°F (190°C) Recommended Minimum Film Thickness 1.5

## EPOXY E-COAT

PHD Manufacturing's epoxy E-Coat offers state of the art corrosion resistance without the use of heavy metals such as lead, chrome, and zinc. It is applied to our products by a controlled cathodic electro-deposition process. This process is accomplished by transporting the product through several cleaning, phosphatizing, rinsing, and application stages prior to being baked for 20 minutes at 375°F (190°C).

### EPOXY PROPERTIES

Property	Test Method	Performance
Color	---	Various
Film Thickness	---	0.5 - 1.5 Mils
Gloss - 60 Degree	ASTM D523	65 - 85
Pencil Hardness	ASTM D3363	2H Minimum
Direct Impact	ASTM D2794	120 in-lb. Minimum
Reverse Impact	ASTM D2794	100 in-lb. Minimum
Cross-Hatch Adhesion	ASTM D3359	4B - 5B
Humidity	ASTM D1735	1000 Hours Minimum
Water Immersion	ASTM D870	250 Hours Minimum
Gravelometer	GM 9508P	6 Minimum
Throwpower	GM 9535P	12 - 15 Inches

All tests performed on Cold Rolled Steel Lab Panels, Zinc Phosphate Pretreatment, 0.6 Mil Average Film Thickness, Cure 20 Minutes @ 375°F

Property	Substrate / Pretreatment	Salt Spray* 500 hrs.	Salt Spray* 1000 hrs.	20 Cycle** Scab
Corrosion Resistance	CRS/Zinc Phos/Non-Chrome	0 in. (0 mm)	0 - 0.039 in. (0 - 1 mm)	0.039 - 0.079 in. (1 - 2 mm)

(Average Total Scribe Creep). \* Salt Spray - ASTM B117  
\*\* Cycle Scab - GM9511P, Cold Rolled Steel Lab Panels  
Cure 20 Minutes @ 375°F (190°C)



## ZINC COATING

PHD offers 3 basic forms of zinc coating on its products:

- 1) **Electro-Galvanized** (Electro-Plated Zinc)
- 2) **Pre-Galvanized**
- 3) **Hot Dipped Galvanized**

For best results, a zinc rich paint should be applied to field cuts. The zinc rich paint will provide immediate protection for these areas and eliminate the short time period for galvanic action to “heal” the damaged coating.

*Note: The corrosion resistance of zinc is based on its thickness, the environment, and the coating process used. The acceptability of galvanized coatings at temperatures above 450°F is at the discretion of the end user.*

### Zinc offers two types of protection:

- **Barrier:** The zinc coating protects the steel substrate from direct contact with the environment
- **Sacrificial:** The zinc coating will protect scratches, cut edges, etc... through an anodic sacrificial process.

### ELECTRO-GALVANIZED “EG” (ASTM B633 SC1 & SC3)

This type of coating is recommended for use indoors in relatively dry areas. The steel is submersed in a bath of zinc salts, through the process of electrolysis, a coating of pure zinc adheres to the steel with a molecular bond. A maximum of 0.5 mils of zinc per side can be applied using this method.

SC1 (Mild) is the standard finish thickness which has a zinc coating of 0.2 mils per side. SC3 (Severe) has a zinc coating of 0.5 mils per side.

### PRE-GALVANIZED “PG” (ASTM A653 COATING G90)

This type of coating is suitable for extended exposure in dry or mildly corrosive atmospheres but not generally recommended for use outdoors in industrial environments. Also known as “mill galvanized” or “hot-dipped mill galvanized” pre-galvanized zinc coatings are produced by rolling the steel coils or sheets through molten zinc, at the steel mill, the material is then cut or slit to size. Zinc near the uncoated edges or weld areas becomes a sacrificial anode which protects the bare areas.

The pre-galvanized material conforms to ASTM A653 with a G90 zinc coating. The zinc thickness per side is nominally 0.75 mils thick or 0.45 oz /sq. ft.

### HOT-DIP GALVANIZED “HDG” (ASTM 123)

Recommended for prolonged outdoor exposure and will usually protect steel in most atmospheric environments. After fabrication the part is immersed in a bath of molten zinc. A metallurgical bond is formed resulting in a zinc coating that coats all surfaces including edges. Please note that some items cannot be hot-dipped galvanized due to design, tolerances, or threaded components. Check with the PHD factory or your local representative when questionable. Threaded components on hot dipped galvanized products will be electro-galvanized.

The hot-dip galvanized coating is typically 2.6 mils or 1.5 oz /sq. ft per side.

As shown in the graph, when the zinc coating is double, the service life is double under most conditions.

Life of Protection vs. Thickness of Zinc  
And Type of Atmosphere

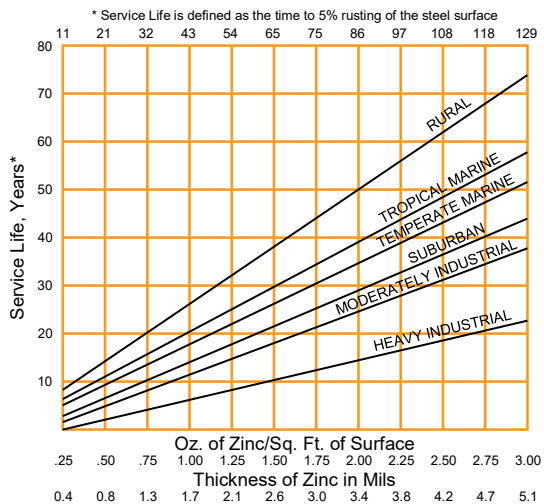

Comparison of Zinc Finishing	
Finish	Zinc Thickness (mils)
Hot-Dip Galvanized	2.6
Pre-Galvanized	0.75
Electro-Galvanized (SC1)	0.2
Electro-Galvanized (SC3)	0.5

# FINISHES & CORROSION

## CORROSION

All metal surfaces are affected by corrosion. Depending on the physical properties of the metal and the environment to which it is exposed, chemical or electromechanical corrosion may occur.

### Atmospheric Corrosion

Atmospheric corrosion occurs when metal is exposed to airborne liquids, solids or gases. Some sources of atmospheric corrosion are moisture, salt, dirt and sulphuric acid. This form of corrosion is typically more severe outdoors, especially near marine environments.

### Chemical Corrosion

Chemical corrosion takes place when metal comes in direct contact with a corrosive solution. Some factors which affect the severity of chemical corrosion include: chemical concentration level, duration of contact, frequency of washing, and operating temperature.

### Galvanic Corrosion

Galvanic corrosion occurs when two or more dissimilar metals are in contact in the presence of an electrolyte (i.e. moisture). An electrolytic cell is created and the metals form an anode or a cathode depending on their relative position on the Galvanic Series Table. The anodic material will be the one to corrode. Anodic or cathodic characteristics of two dissimilar metals will depend on the type of each material. For example: If zinc and steel are in contact, the zinc acts as the anode and will corrode; the steel acts as the cathode, and will be protected. If steel and copper are in contact, the steel is now the anode and will corrode. The rate at which galvanic corrosion occurs depends on several factors:

1. The relative position on the Galvanic Series Table - the further apart materials are in the Galvanic Series Table, the greater the potential for corrosion of the anodic material.
2. The amount and concentration of electrolyte present - an indoor, dry environment will have little or no galvanic corrosion compared to a wet atmosphere.
3. The relative size of the materials – a small amount of anodic material in contact with a large cathodic material will result in greater corrosion. Likewise, a large anode in contact with a small cathode will decrease the rate of attack.

### Storage Corrosion

Wet storage stain (white rust) is caused by the entrapment of moisture between surfaces of closely packed and poorly ventilated material for an extended period. Wet storage stain is usually superficial, having no affect on the properties of the metal.

Light staining normally disappears with weathering. Medium to heavy buildup should be removed in order to allow the formation of normal protective film. Proper handling and storage will help to assure stain-free material. If product arrives wet, it should be unpacked and dried before storage. Dry material should be stored in a well ventilated “low moisture” environment to avoid condensation formation. Outdoor storage is undesirable, and should be avoided whenever possible.

### GALVANIC SERIES IN SEA WATER

 More Anodic	Anodic End
	Magnesium
	Magnesium Alloys
	Zinc (Galvanized Coating)
	Beryllium
	Aluminum - Zinc Alloys
	Aluminum - Magnesium Alloys
	Aluminum
	Aluminum - Magnesium Alloys
	Aluminum - Magnesium - Silicon Alloys
	Cadmium
	Aluminum - Copper Alloys
	Low Carbon Steel, Cast Iron, Wrought Iron
	Austenitic Nickel Cast Iron
	Type 410 Stainless Steel (active)
	Type 316 Stainless Steel (active)
	Type 304 Stainless Steel (active)
	Naval Brass, Yellow Brass, Red Brass
	Tin
	Copper
	Lead-Tin Solders
	Admiralty Brass, Aluminum Brass
	Manganese Bronze
	Silicon Bronze
	Tin Bronze
	Type 410 Stainless Steel (passive)
	Nickel - Silver
	Copper Nickel Alloys
	Lead
	Nickel - Aluminum Bronze
	Silver Solder
	Nickel 200
	Silver
	Type 316 Stainless Steel (passive)
	Type 304 Stainless Steel (passive)
	Incoloy 825
	Hastelloy B
	Titanium
	Hastelloy C
	Platinum
Graphite	
	Cathodic End

Metals in descending order of activity in the presence of an electrolyte.

## CORROSION

The corrosion data given in this table is for general comparison only.

The presence of contaminants and the effect of temperature in chemical environments can greatly affect the corrosion of any material.

PHD Manufacturing, Inc. strongly suggests that field service tests or simulated laboratory tests using actual environmental conditions are conducted in order to determine the proper materials and finishes to be selected.

Chemical	Aluminum	Channel Green	Type 304 Stainless	Type 316 Stainless	Zinc Coated Steel
Acetic Acid 10%	R	NR	R	R	NR
Acetic Acid 2%	R	F	R	R	NR
Acetone	R	R	R	R	R
Ammonium Hydroxide-Conc.	R	R	R	R	-
Ammonium Hydroxide 10%	F	R	R	R	-
Ammonium Hydroxide 2%	R	R	R	R	-
Benzene	R	R	R	R	-
Bromine Water	NR	R	NR	NR	-
Butanol (Butyl Alcohol)	R	R	R	R	R
Carbon Disulfide	R	R	R	R	-
Carbon Tetrachloride	F	R	R	R	-
Chlorine Water	R	R	NR	F	R
Cutting Oil	-	R	-	-	-
Diethanolamine	R	R	-	-	NR
Ethanol	R	R	R	R	R
Ethyl Acetate	R	R	-	-	R
Ethylene Dichloride	F	R	-	-	R
Formaldehyde 20%	R	R	R	R	R
Gasoline	R	R	R	R	R
Glycerine	R	R	R	R	R
Household Detergent 10%	F	R	R	R	-
Hydrochloric Acid 40%	NR	NR	NR	NR	NR
Hydrochloric Acid 10%	NR	F	NR	NR	NR
Hydrochloric Acid 2%	NR	F	NR	NR	NR
Hydrogen Peroxide 30%	R	NR	R	R	-
Hydrogen Peroxide 3%	R	R	R	R	-
Hydrogen Sulfide (Gas)	R	R	F	R	-
JP-4 Jet Fuel	R	R	R	R	-
Lactic Acid 85%	F	R	NR	-	-
Latex	R	R	R	R	NR
Linseed Oil Fatty Acid	R	F	R	R	-
Methanol	R	R	R	R	R
Methyl Ethyl Ketone	R	R	-	-	R
Methyl Isobutyl Ketone	R	R	-	-	R
Mineral Spirits	R	R	-	-	-
Motor Oil - 10W	R	R	R	R	R
Naphtha, VM&P	R	R	R	R	R
Nitric Acid 2%	F	NR	R	R	-
Perchloroethylene	R	R	-	-	NR
Petroleum Ether	-	R	R	R	R
Phenol 10%	R	R	R	R	R
Phosphoric Acid 2%	F	NR	R	R	NR
Potassium Hydroxide 50%	NR	R	R	R	-
Potassium Hydroxide 10%	NR	R	R	R	-
Potassium Hydroxide 2%	NR	R	R	R	-
Sodium Chloride 25%	F	R	R	R	F
Sodium Hydroxide 50%	NR	R	R	R	NR
Sodium Hydroxide 10%	NR	R	R	R	F
Sodium Hydroxide 2%	NR	R	-	-	-
Sodium Hypochlorite-C1. 10%	F	R	-	-	-
Sodium Hypochlorite-C1. 6%	F	R	NR	R	-
Sulfuric Acid 50%	F	NR	NR	R	NR
Tall Oil Fatty Acid 50%	R	R	-	-	-
Tannic Acid 50%	F	R	R	R	-
Water-Deionized	R	R	R	R	F
Water-Sea	F	F	R	R	F
Water-Tap	R	R	F	F	R
Xyol	R	R	-	-	-

R = Recommended

F = May be used under some conditions

NR = Not Recommended

- = Information not available

# THREADED ACCESSORIES

**FIG. 10**

## THREADED STUDS

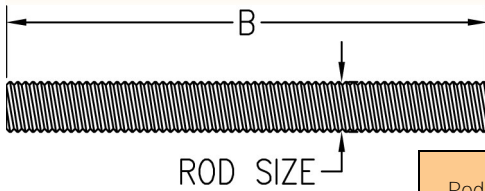

**Function:** Designed for use in pipe hanger assemblies.  
**Material:** Carbon steel (Type 304 or 316 Stainless Steel upon request)  
**Finish:** Plain or electro-galvanized (Hot dipped galvanized upon request)  
**Ordering:** Specify figure number, rod size, length (B), material, and finish.

Rod Size	Max. Rec. Load				Wt. Per Inch	
	650°F (343°C)		750°F (399°C)		lbs.	kg
	lbs.	kN	lbs.	kN		
3/8 x B	730	(3.25)	572	(2.54)	.02	(.01)
1/2 x B	1350	(6.01)	1057	(4.70)	.04	(.02)
5/8 x B	2160	(9.61)	1692	(7.52)	.07	(.03)
3/4 x B	3230	(14.37)	2530	(11.25)	.11	(.05)
7/8 x B	4480	(19.93)	3508	(15.61)	.14	(.06)

**FIG. 15 & 15L**

## MACHINE THREAD HANGER ROD

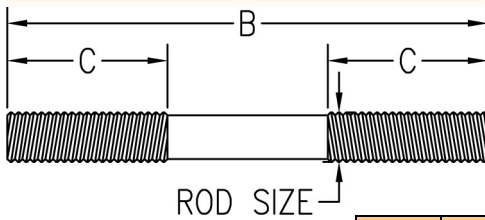

**Function:** Designed for use in pipe hanger assemblies.  
**Right-Hand Threads (Fig. 15) or Right and Left-Hand Threads (Fig. 15L).**  
**Material:** Carbon steel (Type 304 or 316 Stainless Steel upon request)  
**Finish:** Plain or electro-galvanized (Hot dipped galvanized upon request)  
**Ordering:** Specify figure number, rod size, length (B), material, and finish.

Rod Size	Thread Length C	Max. Rec. Load				Wt. Per Inch	
		650°F (343°C)		750°F (399°C)		lbs.	kg
		lbs.	kN	lbs.	kN		
3/8 x B	2 1/2 (63.5)	730	(3.25)	572	(2.54)	.03	(.01)
1/2 x B	2 1/2 (63.5)	1350	(6.01)	1057	(4.70)	.06	(.03)
5/8 x B	2 1/2 (63.5)	2160	(9.61)	1692	(7.52)	.09	(.04)
3/4 x B	3 (76.2)	3230	(14.37)	2530	(11.25)	.13	(.06)
7/8 x B	3 1/2 (88.9)	4480	(19.93)	3508	(15.61)	.17	(.08)
1 x B	4 (101.6)	5900	(26.24)	4620	(20.55)	.22	(.10)

**FIG. 20 & 21**

## CONTINUOUS THREADED ROD

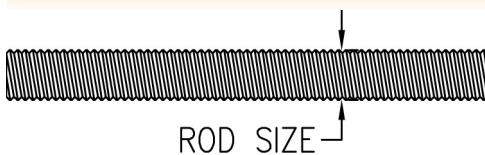

**Function:** Useful in applications where stud lengths cannot be predetermined.  
**Material:** Carbon steel (Type 304 or 316 Stainless Steel upon request)  
**Finish:** Plain (Fig. 20) or electro-galvanized Finish (Fig. 21) (Hot dipped galvanized upon request)  
**Ordering:** Specify figure number, rod size, length, material, and finish.

Rod Size	Packaging Feet Per Bundle						Max. Rec. Load				Wt. Per Foot	
	6ft. (1.83)		10ft. (3.05)		12ft. (3.66)		650°F (343°C)		750°F (399°C)		lbs.	kg
	lbs.	kN	lbs.	kN	lbs.	kN	lbs.	kN				
1/4-20	300	(91.44)	500	(152.4)	600	(182.88)	240	(1.07)	188	(0.84)	.12	(.05)
3/8-16	150	(45.72)	250	(76.2)	240	(73.15)	730	(3.25)	572	(2.54)	.29	(.13)
1/2-13	72	(21.95)	120	(36.58)	144	(43.90)	1350	(6.01)	1057	(4.70)	.54	(.25)
5/8-11	48	(14.63)	80	(24.38)	96	(29.26)	2160	(9.61)	1692	(7.52)	.83	(.38)
3/4-10	30	(9.14)	50	(15.24)	60	(18.29)	3230	(14.37)	2530	(11.25)	1.25	(.57)
7/8-9	24	(7.32)	40	(12.19)	48	(14.63)	4480	(19.93)	3508	(15.61)	1.65	(.75)
1-8	12	(3.66)	20	(6.10)	24	(7.32)	5900	(26.24)	4620	(20.55)	2.25	(1.02)

Unless otherwise specified, all dimensions on drawings and in charts are in inches and dimensions shown in parentheses are in millimeters.

# THREADED ACCESSORIES



## ROD SWIVEL ATTACHMENT

**FIG. 020**

**Function:** May be used as a branch line restraint for structural attachment. May be used in a pitched or sloped roof application, to meet requirements of NFPA 13, or may be used as an upper attachment with short hanger rod to omit seismic bracing.

**Size:**  $\frac{3}{8}$ "

**Material:** Carbon steel

**Finish:** Electro-galvanized

**Install:** Insert a #2 screwdriver through the tapped hole to access the head of attachment fastener. Tighten attachment fastener to desired attachment point, then remove screwdriver and thread  $\frac{3}{8}$ -16 threaded rod into Fig. 020.

**Approvals:** Underwriters' Laboratories Listed in the U.S. (UL) and Canada (CUL).

**Ordering:** Specify figure number.

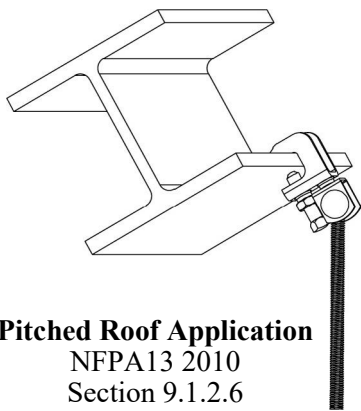
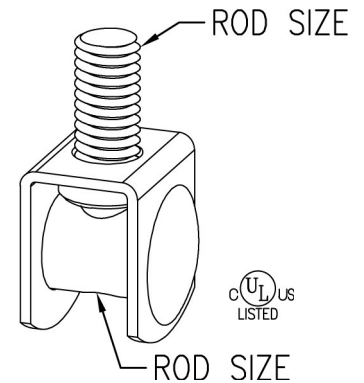

Rod Size	Max. Pipe Size		Max. Rec. Load		Wt. Each	
			lbs.	kN	lbs.	kg
$\frac{3}{8}$	4	(100)	730	(3.25)	.10	(.05)

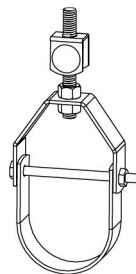

Used as an upper attachment with a short hanger rod to omit seismic bracing

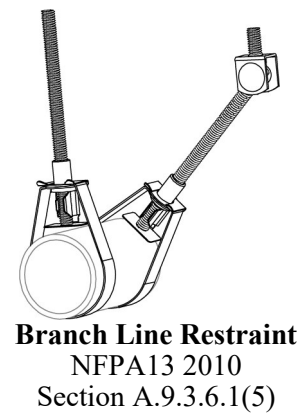

## EXTENSION PIECE

**FIG. 25**

**Function:** Designed for attaching hanger rod to various types of attachments. Allows for vertical adjustment of the rod. Frequently used in conjunction with Fig. 630 malleable iron beam clamp.

**Material:** Malleable iron

**Finish:** Plain or electro-galvanized

**Ordering:** Specify figure number, rod size, and finish.

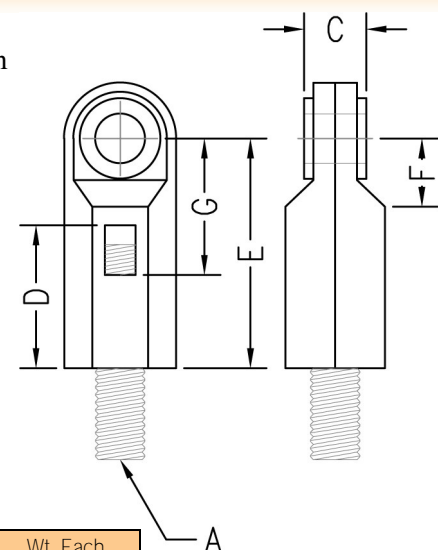

Rod Size A	For Pipe Sizes		B	C	D	
$\frac{3}{8}$	$\frac{1}{2}$ to 2	(15 to 50)	$\frac{1}{2}$ (12.7)	$\frac{1}{2}$ (12.7)	$1\frac{1}{4}$ (31.75)	
$\frac{1}{2}$	$2\frac{1}{2}$ to $3\frac{1}{2}$	(65 to 90)	$\frac{1}{2}$ (12.7)	$\frac{5}{8}$ (15.88)	$1\frac{3}{8}$ (34.93)	
$\frac{5}{8}$	4 & 5	(100 & 125)	$\frac{1}{2}$ (12.7)	$\frac{5}{8}$ (15.88)	$1\frac{1}{2}$ (38.1)	
$\frac{3}{4}$	6 & 8	(150 & 200)	$\frac{1}{2}$ (12.7)	$\frac{5}{8}$ (15.88)	$1\frac{3}{4}$ (44.45)	
$\frac{7}{8}$	10 & 12	(250 & 300)	$\frac{9}{16}$ (14.29)	$\frac{3}{4}$ (19.05)	$1\frac{7}{8}$ (47.63)	

Rod Size A	E		F		G		Max. Rec. Load		Wt. Each	
	lbs.	kg	lbs.	kg	lbs.	kg	lbs.	kg	lbs.	kg
$\frac{3}{8}$	$2\frac{1}{16}$ (52.39)	$\frac{9}{16}$ (14.29)	$1\frac{1}{4}$ (31.75)	730 (3.25)	.20 (.09)					
$\frac{1}{2}$	$2\frac{9}{16}$ (58.74)	$1\frac{11}{16}$ (17.46)	$1\frac{3}{8}$ (34.93)	1350 (6.01)	.43 (.20)					
$\frac{5}{8}$	$2\frac{7}{16}$ (61.91)	$\frac{3}{4}$ (19.05)	$1\frac{7}{16}$ (36.51)	1550 (6.89)	.46 (.21)					
$\frac{3}{4}$	$2\frac{7}{8}$ (73.03)	$\frac{7}{8}$ (22.23)	$1\frac{11}{16}$ (42.86)	2100 (9.34)	.63 (.29)					
$\frac{7}{8}$	3 (76.2)	$\frac{7}{8}$ (22.23)	$1\frac{3}{4}$ (44.45)	2350 (10.45)	.67 (.30)					

Unless otherwise specified, all dimensions on drawings and in charts are in inches and dimensions shown in parentheses are in millimeters.

THREADED ACCESSORIES  
 CPVC STRAPS  
 BAND HANGERS  
 BEAM CLAMPS  
 CLEVIS HANGERS  
 PIPE ROLLER SUPPORTS  
 SPLIT RING HANGERS  
 PIPE CLAMPS  
 CENTER LOAD BEAM CLAMPS  
 PIPE SHIELDS, INSULATION, & SADDLES  
 PIPE GUIDES & SLIDES  
 WALL BRACKETS  
 PIPE SUPPORTS  
 STRUCTURAL ATTACHMENTS  
 SEISMIC BRACING

# THREADED ACCESSORIES

**FIG. 30**

## EYE SOCKET

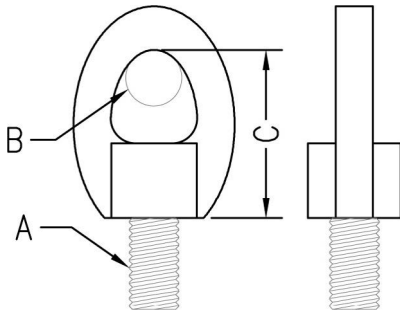

- Function:** Designed for attaching hanger rod to various types of hanger attachments.
- Material:** Malleable iron
- Finish:** Plain or electro-galvanized
- Approvals:** Complies with Federal Specifications A-A-1192A (Type 16) and Manufacturers' Standardization Society ANSI/MSS SP-58 (Type 16) which supersedes ANSI/MSS SP-69.
- Ordering:** Specify figure number, rod size, and finish.

Rod Size A	For Pipe Sizes		Max. Bolt Size B		C		Max. Rec. Load		Wt. Each	
							lbs.	kN	lbs.	kg
1/4	3/8	(10)	1/4	(6.35)	1 3/8	(34.93)	240	(1.07)	.08	(.04)
3/8	1/2 to 2	(15 to 50)	1/4	(6.35)	1 3/8	(34.93)	610	(2.71)	.08	(.04)
1/2	2 1/2 to 3 1/2	(65 to 90)	1/4	(6.35)	1 9/16	(39.69)	1000	(4.45)	.11	(.05)
5/8	4 & 5	(100 & 125)	3/8	(9.53)	1 3/4	(44.45)	1400	(6.23)	.22	(.10)
3/4	6 & 8	(150 & 200)	1/2	(12.7)	2 1/4	(57.15)	2200	(9.79)	.30	(.14)
7/8	10 & 12	(250 & 300)	1/2	(12.7)	2 7/16	(61.91)	2300	(10.23)	.32	(.15)

**FIG. 35 & 35L**

## WELDLESS EYE NUT

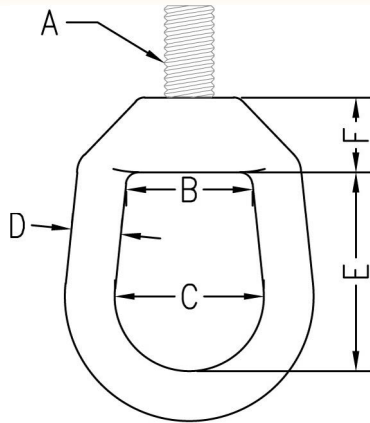

- Function:** Designed for use in high strength and high temperature piping applications. Fig. 35L is designed to be used in conjunction with Fig. 960 forged steel turnbuckle, in applications where a vertical adjustment may be necessary.
- Material:** Forged steel (Type 316 Stainless Steel upon request)
- Finish:** Plain or electro-galvanized (Hot dipped galvanized upon request)
- Approvals:** Complies with Federal Specifications A-A-1192A (Type 17) and Manufacturers' Standardization Society ANSI/MSS SP-58 (Type 17) which supersedes ANSI/MSS SP-69.
- Ordering:** Specify figure number, rod size, material, and finish.

*NOTE: Supports loads equal to the full limitation of the hanger rod.*

Rod Size A	B		C		D		E		F		Max. Rec. Load				Wt. Each	
											650°F (343°C)		750°F (399°C)			
											lbs.	kN	lbs.	kN	lbs.	kg
3/8	1 1/4	(31.75)	1 1/2	(38.1)	1/2	(12.7)	2	(50.8)	1 1/16	(17.46)	730	(3.25)	572	(2.54)	.64	(.29)
1/2	1 1/4	(31.75)	1 1/2	(38.1)	1/2	(12.7)	2	(50.8)	1 1/16	(17.46)	1350	(6.01)	1057	(4.70)	.61	(.28)
5/8	1 1/4	(31.75)	1 1/2	(38.1)	1/2	(12.7)	2	(50.8)	1 1/16	(17.46)	2160	(9.61)	1692	(7.52)	.59	(.27)
3/4	1 1/4	(31.75)	1 1/2	(38.1)	1/2	(12.7)	2	(50.8)	1 1/16	(17.46)	3230	(14.37)	2530	(11.25)	.57	(.26)
7/8	1 1/16	(42.86)	2	(50.8)	3/4	(19.05)	2 5/8	(66.68)	1	(25.4)	4480	(19.93)	3508	(15.61)	1.67	(.76)
1	1 1/16	(42.86)	2	(50.8)	3/4	(19.05)	2 5/8	(66.68)	1	(25.4)	5900	(26.24)	4620	(20.55)	1.65	(.75)
1 1/8	2 1/4	(57.15)	2 1/2	(63.5)	1	(25.4)	3 3/8	(85.73)	1 1/4	(31.75)	7450	(33.14)	5834	(25.95)	3.68	(1.67)
1 1/4	2 1/4	(57.15)	2 1/2	(63.5)	1	(25.4)	3 3/8	(85.73)	1 1/4	(31.75)	9500	(42.26)	7440	(33.09)	3.57	(1.62)
1 1/2	2 1/4	(57.15)	2 1/2	(63.5)	1	(25.4)	3 3/8	(85.73)	1 1/4	(31.75)	13800	(61.39)	10807	(48.07)	3.43	(1.56)

Unless otherwise specified, all dimensions on drawings and in charts are in inches and dimensions shown in parentheses are in millimeters.

# THREADED ACCESSORIES



## STEEL EYE SOCKET

- Function:** Designed for attaching hanger rod to structures. Secured with listed fasteners.
- Material:** Carbon steel
- Finish:** Electro-galvanized
- Approvals:** Underwriters' Laboratories Listed in the U.S. (UL), Canada (CUL), and Factory Mutual Approved.
- Ordering:** Specify figure number and rod size.

**FIG. 36**

Rod Size A	Max. Pipe Size		Screw Size	B		C		Max. Rec. Load		Wt. Each	
								lbs.	kN	lbs.	kg
3/8	2	(50)	3/8 X 2 1/2 Lag	2 5/8	(66.68)	1 1/16	(26.99)	400	(1.78)	.08	(.04)
3/8	4	(100)	3/8 Bolt	2 5/8	(66.68)	1 1/16	(26.99)	730	(3.25)	.08	(.04)

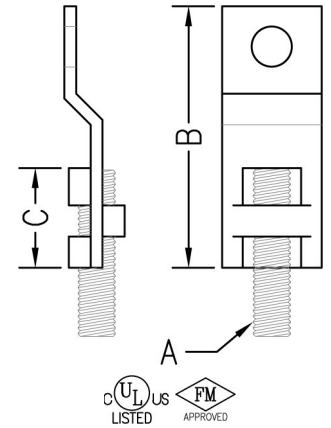

## STEEL EYE SOCKET

- Function:** Designed for attaching hanger rod to wood structures. Secured with Fig. 45 lag screw or two Fig. 48 wood drive screws, see chart.
- Material:** Carbon steel
- Finish:** Electro-galvanized
- Approvals:** Underwriters' Laboratories Listed in the U.S. (UL) and Canada (CUL) for 3/8" and 1/2" rod sizes. Factory Mutual Approved for 3/8" rod size only.
- Ordering:** Specify figure number and rod size.

**FIG. 37**

*NOTE: The 3/8" offset design provides full vertical rod adjustment.*

Rod Size A	Max. Pipe Size		Screw Size	B		C		Max. Rec. Load		Wt. Each	
								lbs.	kN	lbs.	kg
3/8	2	(50)	(2) #16 x 2	3 1/4	(82.55)	1 1/4	(31.75)	400	(1.78)	.11	(.05)
3/8	4	(100)	1/2 x 2 1/2	3 1/4	(82.55)	1 1/4	(31.75)	730	(3.25)	.11	(.05)
1/2	8	(200)	5/8 x 3	2 3/4	(69.85)	1 3/16	(30.16)	1350	(6.01)	.15	(.07)

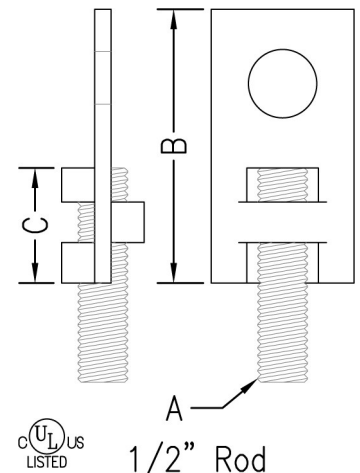
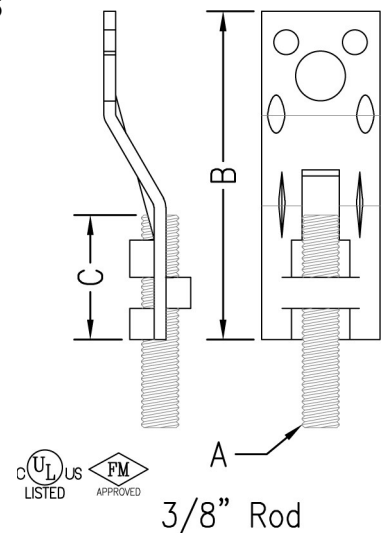

Unless otherwise specified, all dimensions on drawings and in charts are in inches and dimensions shown in parentheses are in millimeters.

THREADED ACCESSORIES  
CPVC STRAPS  
BAND HANGERS  
BEAM CLAMPS  
CLEVIS HANGERS  
PIPE ROLLER SUPPORTS  
SPLIT RING HANGERS  
PIPE CLAMPS  
CENTER LOAD BEAM CLAMPS  
PIPE SHIELDS, INSULATION, & SADDLES  
PIPE GUIDES & SLIDES  
WALL BRACKETS  
PIPE SUPPORTS  
STRUCTURAL ATTACHMENTS  
SEISMIC BRACING

# THREADED ACCESSORIES

**FIG. 38**

## FORGED STEEL CLEVIS

**Function:** Designed for use as a convenient method of connecting hanger rods to pipe lugs, angles, etc. As a structural attachment it is most commonly used in conjunction with Fig. 935 welding lug.

Right-Hand Threads (**Fig. 38**) or Left-Hand Threads (**Fig. 38L**).

**Material:** Forged steel (Type 316 Stainless Steel upon request)

**Finish:** Plain or electro-galvanized (Hot dipped galvanized upon request)

**Approvals:** Complies with Federal Specifications A-A-1192A (Type 14) and Manufacturers' Standardization Society ANSI/MSS SP-58 (Type 14) which supersedes ANSI/MSS SP-69.

**Ordering:** Specify figure number, size number, rod size, with or without pin, and finish. If other than standard combination is required, specify size number, rod size, pin size and grip.

*NOTE: Regularly furnished with pin and cotter pins, unless specified otherwise.*

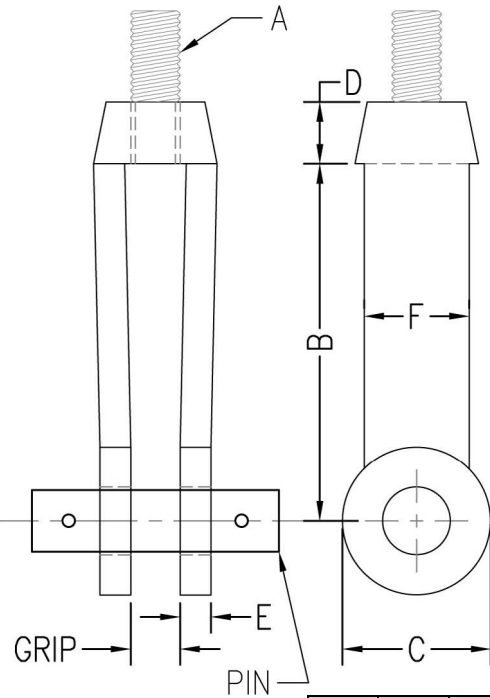

Size No.	Rod Size A	Pin Size		Grip		B		C		D	
2	3/8	1/2	(12.70)	1/2	(12.70)	3 5/8	(92.08)	1 1/2	(38.10)	5/8	(15.88)
2	1/2	5/8	(15.88)	1/2	(12.70)	3 5/8	(92.08)	1 1/2	(38.10)	5/8	(15.88)
2	5/8	3/4	(19.05)	5/8	(15.88)	3 5/8	(92.08)	1 1/2	(38.10)	5/8	(15.88)
2 1/2	3/4	7/8	(22.23)	3/4	(19.05)	5	(127.00)	2	(50.80)	7/8	(22.23)
2 1/2	7/8	1	(25.40)	7/8	(22.23)	5	(127.00)	2	(50.80)	7/8	(22.23)
3	1	1 1/8	(28.58)	1	(25.40)	5	(127.00)	3	(76.20)	1 5/16	(33.34)
3	1 1/4	1 3/8	(34.93)	1 1/4	(31.75)	5	(127.00)	3	(76.20)	1 5/16	(33.34)
3 1/2	1 1/2	1 5/8	(41.28)	1 1/2	(38.10)	6	(152.40)	3 1/2	(88.90)	1 5/8	(41.28)
4	1 3/4	1 7/8	(47.63)	1 1/2	(38.10)	6	(152.40)	4	(101.60)	1 3/4	(44.45)
5	2	2 1/4	(57.15)	2 1/2	(63.50)	7	(177.80)	5	(127.00)	2 1/4	(57.15)
6	2 1/4	2 1/2	(63.50)	2 1/2	(63.50)	8	(203.20)	6	(152.40)	2 3/4	(69.85)
6	2 1/2	2 3/4	(69.85)	2 1/2	(63.50)	8	(203.20)	6	(152.40)	2 3/4	(69.85)
7	2 3/4	3	(76.20)	2 1/2	(63.50)	8	(203.20)	7	(177.80)	3	(76.20)
7	3	3 1/4	(82.55)	2 1/2	(63.50)	9	(228.60)	7	(177.80)	3	(76.20)

Supports loads equal to the full limitation of the hanger rod.

Size No.	Rod Size A	E		F		Max Rec. Load				Wt. Each			
						650°F (343°C)		750°F (399°C)		w/o pin		with pin	
						lbs.	kN	lbs.	kN	lbs.	kg	lbs.	kg
2	3/8	5/16	(7.94)	1 1/16	(26.99)	730	(3.25)	572	(2.54)	.9	(0.41)	1.0	(.45)
2	1/2	5/16	(7.94)	1 1/16	(26.99)	1350	(6.01)	1057	(4.70)	.7	(0.32)	.9	(.41)
2	5/8	5/16	(7.94)	1 1/16	(26.99)	2160	(9.61)	1692	(7.52)	.7	(0.32)	.9	(.41)
2 1/2	3/4	3/8	(9.53)	1 1/4	(31.75)	3230	(14.37)	2530	(11.25)	2.5	(1.13)	3.0	(1.36)
2 1/2	7/8	3/8	(9.53)	1 1/4	(31.75)	4480	(19.93)	3508	(15.61)	2.5	(1.13)	3.4	(1.54)
3	1	1/2	(12.70)	1 1/2	(38.10)	5900	(26.24)	4620	(20.55)	4.0	(1.81)	5.1	(2.31)
3	1 1/4	1/2	(12.70)	1 1/2	(38.10)	9500	(42.26)	7440	(33.09)	3.8	(1.72)	5.5	(2.49)
3 1/2	1 1/2	1/2	(12.70)	1 3/4	(44.45)	13800	(61.39)	10807	(48.07)	6.0	(2.72)	8.5	(3.86)
4	1 3/4	1/2	(12.70)	2	(50.80)	18600	(82.74)	14566	(64.79)	8.0	(3.63)	12.9	(5.85)
5	2	5/8	(15.88)	2 1/2	(63.50)	24600	(109.43)	19265	(85.70)	16.0	(7.26)	23.3	(10.57)
6	2 1/4	3/4	(19.05)	3	(76.20)	32300	(143.68)	25295	(112.52)	26.0	(11.79)	35.1	(15.92)
6	2 1/2	3/4	(19.05)	3	(76.20)	39800	(177.04)	31169	(138.65)	25.5	(11.57)	36.0	(16.33)
7	2 3/4	7/8	(22.23)	3 1/2	(88.90)	49400	(219.74)	38687	(172.09)	36.0	(16.33)	50.0	(22.68)
7	3	7/8	(22.23)	3 1/2	(88.90)	60100	(267.34)	47066	(209.36)	35.0	(15.88)	51.5	(23.36)

Unless otherwise specified, all dimensions on drawings and in charts are in inches and dimensions shown in parentheses are in millimeters.



# THREADED ACCESSORIES



## COACH SCREW ROD

FIG. 40

- Function:** Designed for use as a vertical hanger attachment to wood structures.  
**Material:** Carbon steel  
**Finish:** Plain or electro-galvanized  
**Ordering:** Specify figure number, rod size, length (D), and finish.

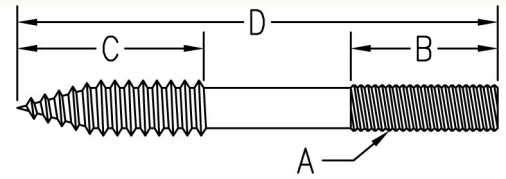

Rod Size A	Minimum Length				Max. Rec Load		Wt. Each									
	Machine B		Coach C		lbs.	kN	Length D									
							4 (101.6)		6 (152.4)		8 (203.2)		10 (254.0)		12 (304.8)	
						lbs.	kg	lbs.	kg	lbs.	kg	lbs.	kg	lbs.	kg	
3/8	2	(50.80)	2	(50.80)	390	(1.73)	.12	(0.05)	.19	(0.09)	.25	(0.11)	.31	(0.14)	.37	(0.17)
1/2	2	(50.80)	2 1/2	(63.50)	640	(2.85)	.22	(0.10)	.34	(0.15)	.44	(0.20)	.56	(0.25)	.67	(0.30)

## HEX HEAD BOLT

FIG. 41

- Function:** Designed for use as a fastening device.  
**Material:** Carbon steel (Type 304 or 316 Stainless Steel upon request)  
**Finish:** Plain or electro-galvanized (Hot dipped galvanized upon request)  
**Ordering:** Specify figure number, diameter, length (B), material, and finish. If nuts are required, refer to Fig. 110 or 110H.

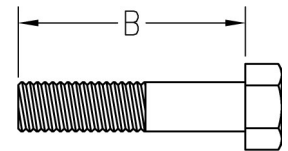

*NOTE: Regularly furnished without nut.*

Length B		Wt. Each							
		5/8" Dia.		3/4" Dia.		7/8" Dia.		1" Dia.	
		lbs.	kg	lbs.	kg	lbs.	kg	lbs.	kg
2	(50.80)	.23	(0.10)	.35	(0.16)	--	--	--	--
2 1/4	(57.15)	.25	(0.11)	.39	(0.18)	--	--	--	--
2 1/2	(63.50)	.27	(0.12)	.42	(0.19)	.60	(0.27)	--	--
2 3/4	(69.85)	.29	(0.13)	.45	(0.20)	.64	(0.29)	.85	(0.39)
3	(76.20)	.32	(0.15)	.48	(0.22)	.68	(0.31)	.92	(0.42)
3 1/4	(82.55)	.34	(0.15)	.51	(0.23)	.72	(0.33)	.94	(0.43)
3 1/2	(88.90)	.36	(0.16)	.54	(0.24)	.76	(0.34)	.96	(0.44)
3 3/4	(95.25)	.38	(0.17)	.57	(0.26)	.80	(0.36)	1.10	(0.50)
4	(101.60)	.40	(0.18)	.60	(0.27)	.85	(0.39)	1.11	(0.50)

THREADED ACCESSORIES  
 CPVC STRAPS  
 BAND HANGERS  
 BEAM CLAMPS  
 CLEVIS HANGERS  
 PIPE ROLLER SUPPORTS  
 SPLIT RING HANGERS  
 PIPE CLAMPS  
 CENTER LOAD BEAM CLAMPS  
 PIPE SHIELDS, INSULATION, & SADDLES  
 PIPE GUIDES & SLIDES  
 WALL BRACKETS  
 PIPE SUPPORTS  
 STRUCTURAL ATTACHMENTS  
 SEISMIC BRACING

# THREADED ACCESSORIES

**FIG. 47**

## CONCRETE ANCHORS

**Fig. 47S**  
STEEL DROP-IN

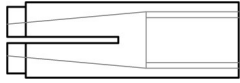

**Function:** Designed to be inserted into a pre-drilled hole and set into place by means of a setting tool.  
**Material:** Carbon steel  
**Finish:** Electro-galvanized  
**Ordering:** Specify figure number and rod size.

Rod Size	Hole Size		Anchor Length		Thread Length		Wt. Each	
	in.	mm	in.	mm	in.	mm	lbs.	kg
3/8	1/2	(12.70)	1 1/16	(39.69)	5/8	(15.88)	.07	(.03)
1/2	5/8	(15.88)	2	(50.80)	3/4	(19.05)	.13	(.06)
5/8	3/4	(19.05)	2 1/2	(63.50)	1	(25.40)	.28	(.13)

**Fig. 47W**  
WEDGE

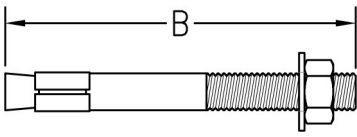

**Function:** Designed to be driven into a pre-drilled hole. The expansion of the case is controlled by the tightening of the nut, this eliminates the need for an exact hole size. Useful in applications where a high resistance to vibratory loads is desired.  
**Material:** Carbon steel  
**Finish:** Electro-galvanized  
**Ordering:** Specify figure number, length (B), and rod size.

Rod Size	Thread Length		Minimum Embedment		Wt. Each	
	in.	mm	in.	mm	lbs.	kg
3/8 x B	1 1/8	(28.58)	1 5/8	(41.28)	.03	(.01)
1/2 x B	1 1/4	(31.75)	2 1/4	(57.15)	.06	(.03)
5/8 x B	1 1/2	(38.10)	2 3/4	(69.85)	.11	(.05)

**FIG. 48**

## WOOD DRIVE SCREW

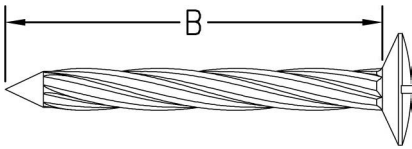

**Function:** Designed for use as a fastening device to wood structures.  
**Material:** Carbon steel  
**Finish:** Plain or electro-galvanized  
**Ordering:** Specify figure number, size number, length (B), and finish.

Size No.	Length B		Wt. Each	
	in.	mm	lbs.	kg
14	1 1/2	(38.10)	.016	(.007)
16	2	(50.80)	.025	(.011)

# THREADED ACCESSORIES



## EYE RODS

## FIG. 50 - 55L

**Function:** Designed for use in hanger assemblies. The welded design allows the eye to develop the full strength of the rod.

Right-Hand Threads (**Fig. 50 & 55**) or Left-Hand Threads (**Fig. 50L & 55L**).

**Material:** Carbon steel (Type 304 or 316 Stainless Steel upon request)

**Finish:** Plain or electro-galvanized (Hot dipped galvanized upon request)

**Ordering:** Specify figure number, length (D), rod size, material, and finish.

**Fig. 50 & 50L**  
EYE ROD

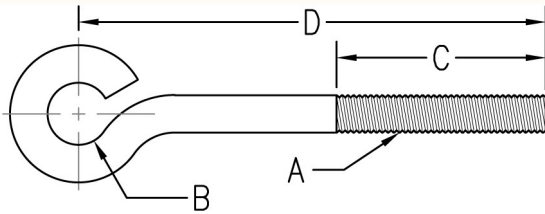

**Fig. 55 & 55L**  
WELDED EYE ROD

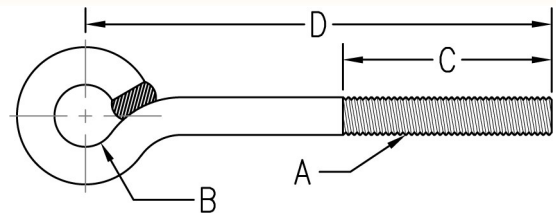

Rod Size A	B		Thread Length C		Max. Rec. Load	
					650°F (343°C)	
					lbs.	kN
3/8	5/8	(15.88)	2 1/2	(63.50)	240	(1.07)
1/2	3/4	(19.05)	2 1/2	(63.50)	440	(1.96)
5/8	7/8	(22.23)	2 1/2	(63.50)	705	(3.14)
3/4	1	(25.40)	3	(76.20)	1050	(4.67)
7/8	1 1/8	(28.58)	3 1/2	(88.90)	1470	(6.54)
1	1 1/4	(31.75)	4	(101.60)	1940	(8.63)

Rod Size A	B		Thread Length C		Max. Rec. Load			
					650°F (343°C)		750°F (399°C)	
					lbs.	kN	lbs.	kN
3/8	5/8	(15.88)	2 1/2	(63.50)	730	(3.25)	572	(2.54)
1/2	3/4	(19.05)	2 1/2	(63.50)	1350	(6.01)	1057	(4.70)
5/8	7/8	(22.23)	2 1/2	(63.50)	2160	(9.61)	1692	(7.52)
3/4	1	(25.40)	3	(76.20)	3230	(14.37)	2530	(11.25)
7/8	1 1/8	(28.58)	3 1/2	(88.90)	4480	(19.93)	3508	(15.61)
1	1 1/4	(31.75)	4	(101.60)	5900	(26.24)	4620	(20.55)

Rod Size A	Wt. Each													
	Length D													
	8 (203.2)		10 (254.0)		12 (304.8)		14 (355.6)		18 (457.2)		24 (609.6)		30 (762.0)	
	lbs.	kg	lbs.	kg	lbs.	kg	lbs.	kg	lbs.	kg	lbs.	kg	lbs.	kg
3/8	.32	(0.15)	.38	(0.17)	.44	(0.20)	.50	(0.23)	.63	(0.29)	.80	(0.36)	1.00	(0.45)
1/2	.60	(0.27)	.70	(0.32)	.82	(0.37)	.94	(0.43)	1.16	(0.53)	1.50	(0.68)	1.83	(0.83)
5/8	.97	(0.44)	1.14	(0.52)	1.31	(0.59)	1.49	(0.68)	1.84	(0.83)	2.36	(1.07)	2.88	(1.31)
3/4	1.44	(0.65)	1.68	(0.76)	1.94	(0.88)	2.19	(0.99)	2.68	(1.22)	3.44	(1.56)	4.19	(1.90)
7/8	2.04	(0.93)	2.32	(1.05)	2.68	(1.22)	3.02	(1.37)	3.73	(1.69)	4.72	(2.14)	5.74	(2.60)
1	2.67	(1.21)	3.11	(1.41)	3.56	(1.61)	4.00	(1.81)	4.89	(2.22)	6.78	(3.08)	8.18	(3.71)

Rod Size A	Wt. Each													
	Length D													
	36 (914.4)		42 (1066.8)		48 (1219.2)		54 (1371.6)		60 (1524.0)		66 (1676.4)		72 (1828.8)	
	lbs.	kg	lbs.	kg	lbs.	kg	lbs.	kg	lbs.	kg	lbs.	kg	lbs.	kg
3/8	1.18	(0.54)	1.39	(0.63)	1.58	(0.72)	1.76	(0.80)	1.95	(0.88)	2.14	(0.97)	2.33	(1.06)
1/2	2.17	(0.98)	2.49	(1.13)	2.83	(1.28)	3.16	(1.43)	3.49	(1.58)	3.83	(1.74)	4.06	(1.84)
5/8	3.40	(1.54)	3.92	(1.78)	4.44	(2.01)	4.96	(2.25)	5.48	(2.49)	6.00	(2.72)	6.52	(2.96)
3/4	4.94	(2.24)	5.70	(2.59)	6.45	(2.93)	7.20	(3.27)	7.95	(3.61)	8.70	(3.95)	9.45	(4.29)
7/8	6.76	(3.07)	7.81	(3.54)	8.83	(4.01)	9.85	(4.47)	10.87	(4.93)	11.89	(5.39)	12.91	(5.86)
1	8.89	(4.03)	10.48	(4.75)	11.87	(5.38)	13.19	(5.98)	14.51	(6.58)	15.91	(7.22)	17.25	(7.82)

Unless otherwise specified, all dimensions on drawings and in charts are in inches and dimensions shown in parentheses are in millimeters.

THREADED ACCESSORIES  
CPVC STRAPS  
BAND HANGERS  
BEAM CLAMPS  
CLEVIS HANGERS  
PIPE ROLLER SUPPORTS  
PIPE RING HANGERS  
SPLIT RING HANGERS  
PIPE CLAMPS  
CENTER LOAD BEAM CLAMPS  
PIPE SHIELDS, INSULATION, & SADDLES  
PIPE GUIDES & SLIDES  
WALL BRACKETS  
PIPE SUPPORTS  
STRUCTURAL ATTACHMENTS  
SEISMIC BRACING

# THREADED ACCESSORIES

## FIG. 90, 91, 93, 94, & 90S

## STANDARD U-BOLT

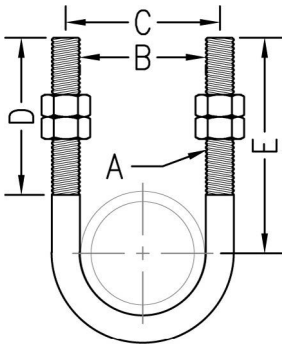

**Function:** Designed for use as a support, anchor, or guide for various types of pipe. The PVC coating on Fig. 93 protects the surface of the pipe from contact with the metal surface of the U-Bolt.

**Material:** Carbon steel or Type 304 & 316 Stainless Steel (**Fig. 94**)

**Finish:** Plain (**Fig. 90**), Electro-Galvanized (**Fig. 91**), or PVC (**Fig. 93**) (Hot dipped galvanized upon request)

**Approvals:** Complies with Federal Specifications A-A-1192A (Type 24) and Manufacturers' Standardization Society ANSI/MSS SP-58 (Type 24) which supersedes ANSI/MSS SP-69.

**Ordering:** Specify figure number, pipe size, material, and finish.

*NOTE: Regularly furnished with nuts.*

Pipe Size		Rod Size A	B		C		D		Tangent E	Max. Rec. Load				Wt. Each		
										650°F (343°C)		750°F (399°C)		lbs.	kg	
										lbs.	kN	lbs.	kN			
1/2	(15)	1/4	15/16	(23.81)	1 3/16	(30.16)	2 3/8	(60.33)	2 3/4	(69.85)	580	(2.58)	454	(2.02)	.11	(.05)
3/4	(20)	1/4	1 1/8	(28.58)	1 3/8	(34.93)	2 3/8	(60.33)	2 3/4	(69.85)	580	(2.58)	454	(2.02)	.12	(.05)
1	(25)	1/4	1 3/8	(34.93)	1 5/8	(41.28)	2 3/8	(60.33)	2 3/4	(69.85)	580	(2.58)	454	(2.02)	.12	(.05)
1 1/4	(32)	3/8	1 11/16	(42.86)	2 1/16	(52.39)	2 3/8	(60.33)	2 7/8	(73.03)	1460	(6.49)	1143	(5.09)	.28	(.13)
1 1/2	(40)	3/8	2	(50.80)	2 3/8	(60.33)	2 1/2	(63.50)	3	(76.20)	1460	(6.49)	1143	(5.09)	.30	(.14)
2	(50)	3/8	2 7/16	(61.91)	2 13/16	(71.44)	2 1/2	(63.50)	3 1/4	(82.55)	1460	(6.49)	1143	(5.09)	.33	(.15)
2 1/2	(65)	1/2	2 5/16	(74.61)	3 7/16	(87.31)	3	(76.20)	3 3/4	(95.25)	2700	(12.01)	2114	(9.41)	.73	(.33)
3	(80)	1/2	3 9/16	(90.49)	4 1/16	(103.19)	3	(76.20)	4	(101.60)	2700	(12.01)	2114	(9.41)	.78	(.35)
3 1/2	(90)	1/2	4 1/16	(103.19)	4 9/16	(115.89)	3	(76.20)	4 1/4	(107.95)	2700	(12.01)	2114	(9.41)	.84	(.38)
4	(100)	1/2	4 9/16	(115.89)	5 1/16	(128.59)	3	(76.20)	4 1/2	(114.30)	2700	(12.01)	2114	(9.41)	.90	(.41)
5	(125)	1/2	5 5/8	(142.88)	6 1/8	(155.58)	3	(76.20)	5	(127.00)	2700	(12.01)	2114	(9.41)	1.01	(.46)
6	(150)	5/8	6 3/4	(171.45)	7 3/8	(187.33)	3 3/4	(95.25)	6 1/8	(155.58)	4320	(19.22)	3383	(15.05)	2.00	(.91)
8	(200)	5/8	8 3/4	(222.25)	9 3/8	(238.13)	3 3/4	(95.25)	7 1/8	(180.98)	4320	(19.22)	3383	(15.05)	2.33	(1.06)
10	(250)	3/4	10 7/8	(276.23)	11 5/8	(295.28)	4	(101.60)	8 3/8	(212.73)	6460	(28.74)	5059	(22.50)	4.91	(2.23)
12	(300)	7/8	12 7/8	(327.03)	13 3/4	(349.25)	4 1/4	(107.95)	9 5/8	(244.48)	8960	(39.86)	7017	(31.21)	7.73	(3.51)
14	(350)	7/8	14 1/8	(358.78)	15	(381.00)	4 1/4	(107.95)	10 1/4	(260.35)	8960	(39.86)	7017	(31.21)	8.30	(3.76)
16	(400)	7/8	16 1/8	(409.58)	17	(431.80)	4 1/4	(107.95)	11 1/4	(285.75)	8960	(39.86)	7017	(31.21)	9.20	(4.17)
18	(450)	1	18 1/8	(460.38)	19 1/8	(485.78)	4 3/4	(120.65)	12 5/8	(320.68)	11800	(52.49)	9241	(41.11)	13.5	(6.12)
20	(500)	1	20 1/8	(511.18)	21 1/8	(536.58)	4 3/4	(120.65)	13 5/8	(346.08)	11800	(52.49)	9241	(41.11)	14.6	(6.62)
24	(600)	1	24 1/8	(612.78)	25 1/8	(638.18)	4 3/4	(120.65)	15 5/8	(396.88)	11800	(52.49)	9241	(41.11)	16.9	(7.67)
30	(750)	1	30 1/8	(765.18)	31 1/8	(790.58)	4 3/4	(120.65)	18 5/8	(473.08)	11800	(52.49)	9241	(41.11)	19.1	(8.66)
36	(900)	1	36 1/8	(917.58)	37 1/8	(942.98)	4 3/4	(120.65)	21 5/8	(549.28)	11800	(52.49)	9241	(41.11)	23.2	(10.52)

**Fig. 90S**  
SPECIAL U-BOLT

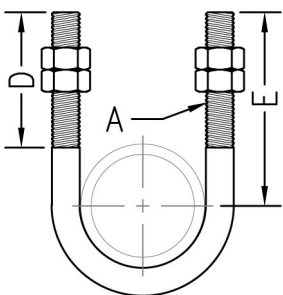

Fig. 90S Special U-Bolts are available upon request. Please specify:

- Figure Number
- Pipe Size
- Rod Size "A"
- Length of Threads "D"
- Tangent "E"
- Material
- Finish

Unless otherwise specified, all dimensions on drawings and in charts are in inches and dimensions shown in parentheses are in millimeters.

# THREADED ACCESSORIES



## LIGHT DUTY U-BOLT

FIG. 95

- Function:** Designed for use as a support, anchor, or guide for various types of pipe in light duty applications.
- Material:** Carbon steel (Type 304 or 316 Stainless Steel upon request)
- Finish:** Plain or electro-galvanized (Hot dipped galvanized upon request)
- Ordering:** Specify figure number, pipe size, material, and finish. If nuts are required, order Fig. 110 separately.

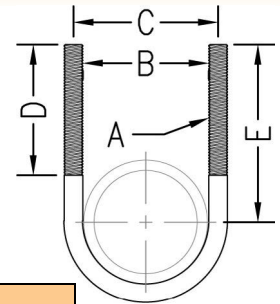

*NOTE: Regularly furnished without nuts unless specified otherwise.*

Pipe Size		Rod Size A		B		C		D		Tangent E		Max. Rec. Load		Wt. Each	
												lbs.	kN	lbs.	kg
1/2	(15)	1/4	15/16	(23.81)	1 3/16	(30.16)	1 3/4	(44.45)	1 15/16	(49.21)	580	(2.58)	.06	(0.03)	
3/4	(20)	1/4	1 1/8	(28.58)	1 3/8	(34.93)	1 3/4	(44.45)	2 1/16	(52.39)	580	(2.58)	.07	(0.03)	
1	(25)	1/4	1 3/8	(34.93)	1 5/8	(41.28)	1 3/4	(44.45)	2 3/16	(55.56)	580	(2.58)	.07	(0.03)	
1 1/4	(32)	1/4	1 11/16	(42.86)	1 15/16	(49.21)	1 3/4	(44.45)	2 3/8	(60.33)	580	(2.58)	.08	(0.04)	
1 1/2	(40)	1/4	2	(50.80)	2 1/4	(57.15)	1 3/4	(44.45)	2 7/16	(61.91)	580	(2.58)	.09	(0.04)	
2	(50)	1/4	2 7/16	(61.91)	2 11/16	(68.26)	1 3/4	(44.45)	2 11/16	(68.26)	580	(2.58)	.10	(0.05)	
2 1/2	(65)	3/8	2 5/16	(74.61)	3 5/16	(84.14)	2	(50.80)	3 1/16	(77.79)	1460	(6.49)	.28	(0.13)	
3	(80)	3/8	3 9/16	(90.49)	3 15/16	(100.01)	2	(50.80)	3 3/8	(85.73)	1460	(6.49)	.31	(0.14)	
3 1/2	(90)	3/8	4 1/16	(103.19)	4 7/16	(112.71)	2	(50.80)	3 5/8	(92.08)	1460	(6.49)	.35	(0.16)	
4	(100)	3/8	4 9/16	(115.89)	4 15/16	(125.41)	2	(50.80)	3 7/8	(98.43)	1460	(6.49)	.38	(0.17)	
5	(125)	3/8	5 5/8	(142.88)	6	(152.40)	2 1/4	(57.15)	4 9/16	(115.89)	1460	(6.49)	.45	(0.20)	
6	(150)	1/2	6 3/4	(171.45)	7 1/4	(184.15)	2 1/4	(57.15)	5 1/16	(128.59)	2700	(12.01)	.95	(0.43)	
8	(200)	1/2	8 3/4	(222.25)	9 1/4	(234.95)	2 1/4	(57.15)	6 1/16	(153.99)	2700	(12.01)	1.20	(0.54)	
10	(250)	5/8	10 7/8	(276.23)	11 1/2	(292.10)	2 1/2	(63.50)	7 1/4	(184.15)	4320	(19.22)	2.30	(1.04)	

## STANDARD ROD COUPLING

FIG. 100

- Function:** Designed to provide a means of connecting two lengths of threaded rod with equal diameters.
- Material:** Carbon steel (Type 304 or 316 Stainless Steel upon request)
- Finish:** Plain or electro-galvanized
- Ordering:** Specify figure number, rod size, material, and finish.

Rod Size	Length		Hex Width		Max. Rec. Load		Wt. Each	
	lbs.	mm	lbs.	mm	lbs.	kN	lbs.	kg
1/4	7/8	(22.23)	3/8	(9.53)	240	(1.07)	.06	(0.03)
3/8	1 3/4	(44.45)	5/8	(15.88)	730	(3.25)	.11	(0.05)
1/2	1 3/4	(44.45)	1 1/16	(17.46)	1350	(6.01)	.11	(0.05)
5/8	2 1/8	(53.98)	1 3/16	(20.64)	2160	(9.61)	.17	(0.08)
3/4	2 1/4	(31.75)	1	(25.40)	3230	(14.37)	.28	(0.13)
7/8	2 1/2	(63.50)	1 1/4	(31.75)	4480	(19.93)	.56	(0.25)
1	2 3/4	(69.85)	1 3/8	(34.93)	5900	(26.24)	.72	(0.33)

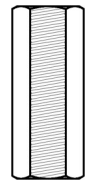

## SHORT PATTERN ROD COUPLING

FIG. 104

- Function:** Designed to provide a means of connecting two lengths of threaded rod with equal diameters.
- Material:** Carbon steel
- Finish:** Plain or electro-galvanized
- Ordering:** Specify figure number, rod size, and finish.

Rod Size	Length		Hex Width		Max. Rec. Load		Wt. Each	
	lbs.	mm	lbs.	mm	lbs.	kN	lbs.	kg
3/8	1 1/8	(28.58)	1/2	(12.70)	730	(3.25)	.04	(0.02)
1/2	1 1/4	(31.75)	5/8	(15.88)	1350	(6.01)	.06	(0.03)

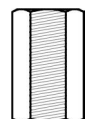

Unless otherwise specified, all dimensions on drawings and in charts are in inches and dimensions shown in parentheses are in millimeters.

THREADED ACCESSORIES  
CPVC STRAPS  
BAND HANGERS  
BEAM CLAMPS  
CLEVIS HANGERS  
PIPE ROLLER SUPPORTS  
SPLIT RING HANGERS  
PIPE CLAMPS  
CENTER LOAD BEAM CLAMPS  
PIPE SHIELDS, INSULATION, & SADDLES  
PIPE GUIDES & SLIDES  
WALL BRACKETS  
PIPE SUPPORTS  
STRUCTURAL ATTACHMENTS  
SEISMIC BRACING

# THREADED ACCESSORIES

**FIG. 105**

## REDUCING ROD COUPLING

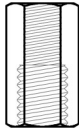

**Function:** Designed to provide a means of connecting two lengths of threaded rod with different diameters.

**Material:** Carbon steel  
**Finish:** Plain or electro-galvanized  
**Ordering:** Specify figure number, rod size, and finish.

Rod Size	Length		Hex Width		Max. Rec. Load		Wt. Each	
					lbs.	kN	lbs.	kg
3/8 x 1/4	1	(25.40)	1/2	(12.70)	240	(1.07)	.04	(0.02)
1/2 x 3/8	1 1/4	(31.75)	5/8	(15.88)	730	(3.25)	.07	(0.03)
5/8 x 1/2	1 1/4	(31.75)	13/16	(20.64)	1350	(6.01)	.14	(0.06)
3/4 x 5/8	1 1/2	(38.10)	1	(25.40)	2160	(9.61)	.13	(0.06)
7/8 x 3/4	1 3/4	(44.45)	1 1/4	(31.75)	3230	(14.37)	.26	(0.12)

**FIG. 110 & 110H**

## HEX NUT

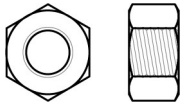

**Function:** Designed for use as a fastening device.

**Material:** Carbon steel (Type 304 or 316 Stainless Steel upon request)  
**Finish:** Plain or electro-galvanized (Hot dipped galvanized upon request)  
**Ordering:** Specify figure number, rod size, material, and finish.  
 Standard Hex Nut (**Fig. 110**) or Heavy Hex Nut (**Fig. 110H**).

Rod Size	Wt. Each																					
	1/4		5/16		3/8		1/2		5/8		3/4		7/8		1		1 1/8		1 1/4		1 1/2	
	lbs.	kg	lbs.	kg	lbs.	kg	lbs.	kg	lbs.	kg	lbs.	kg	lbs.	kg	lbs.	kg	lbs.	kg	lbs.	kg	lbs.	kg
Fig. 110	.01	(.01)	.01	(.01)	.02	(.01)	.04	(.02)	.07	(.03)	.12	(.05)	.19	(.09)	.28	(.13)	.40	(.18)	.54	(.24)	.94	(.43)
Fig. 110H	--	--	--	--	.03	(.01)	.07	(.03)	.12	(.05)	.19	(.09)	.30	(.14)	.43	(.20)	.59	(.27)	.79	(.36)	1.31	(.59)

**FIG. 130**

## FLAT WASHER

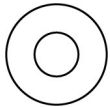

**Function:** Designed to provide a greater bearing surface diameter.  
**Material:** Carbon steel (Type 304 or 316 Stainless Steel upon request)  
**Finish:** Plain or electro-galvanized (Hot dipped galvanized upon request)  
**Ordering:** Specify figure number, rod size, material, and finish.

Rod Size	1/4		3/8		1/2		5/8		3/4		7/8		1		1 1/8		1 1/4		1 1/2	
	I.D.	O.D.	I.D.	O.D.	I.D.	O.D.	I.D.	O.D.	I.D.	O.D.	I.D.	O.D.	I.D.	O.D.	I.D.	O.D.	I.D.	O.D.	I.D.	O.D.
I.D.	5/16 (7.94)	7/16 (11.11)	9/16 (14.29)	11/16 (17.46)	13/16 (20.64)	15/16 (23.81)	1 1/16 (26.99)	1 1/4 (31.75)	1 3/8 (34.93)	1 5/8 (41.28)										
O.D.	3/4 (19.05)	1 (25.40)	1 3/8 (34.93)	1 3/4 (44.45)	2 (50.80)	2 1/4 (57.15)	2 1/2 (63.50)	2 3/4 (69.85)	3 (76.20)	3 1/2 (88.90)										
Wt. Each	lbs.	.01	.02	.04	.08	.11	.15	.19	.22	.26	.38									
	kg	(.01)	(.01)	(.02)	(.04)	(.05)	(.07)	(.09)	(.10)	(.12)	(.17)									

**FIG. 134**

## LOCK WASHER



**Function:** Designed to prevent threaded fasteners from un-threading over time.  
**Material:** Carbon steel (Type 304 or 316 Stainless Steel upon request)  
**Finish:** Plain or electro-galvanized (Hot dipped galvanized upon request)  
**Ordering:** Specify figure number, rod size, material, and finish.

Rod Size	I.D.		O.D.		Wt. Each	
	lbs.	kg	lbs.	kg	lbs.	kg
3/8	7/16	(11.11)	11/16	(17.46)	.007	(.003)
1/2	9/16	(14.29)	7/8	(22.23)	.015	(.007)
5/8	11/16	(17.46)	1 1/16	(26.99)	.026	(.012)
3/4	13/16	(20.64)	1 1/4	(31.75)	.043	(.020)

Unless otherwise specified, all dimensions on drawings and in charts are in inches and dimensions shown in parentheses are in millimeters.

# THREADED ACCESSORIES



## BEVEL WASHER

**FIG. 135**

- Function:** Designed to be used on a tapered surface to permit the fastening of a bolt at a right angle.  
**Material:** Malleable iron  
**Finish:** Plain or electro-galvanized  
**Ordering:** Specify figure number, rod size, and finish.

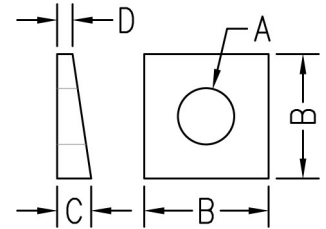

Rod Size	B		C		D		Wt. Each	
	in.	mm	in.	mm	in.	mm	lbs.	kg
3/8	1 1/4	(31.75)	1 1/32	(8.73)	5/32	(3.97)	.09	(.04)
1/2	1 1/4	(31.75)	1 1/32	(8.73)	5/32	(3.97)	.09	(.04)
5/8	1 3/4	(44.45)	1 3/32	(10.32)	5/32	(3.97)	.14	(.06)
3/4	1 1/2	(38.10)	1 5/32	(11.91)	7/32	(5.56)	.16	(.07)
7/8	2	(50.80)	9/16	(14.29)	7/32	(5.56)	.33	(.15)

## FENDER WASHER

**FIG. 136**

- Function:** Designed to provide a greater bearing surface diameter.  
**Material:** Carbon steel  
**Finish:** Electro-galvanized  
**Ordering:** Specify figure number and rod size.

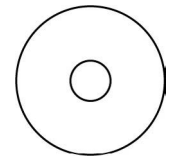

Rod Size	I.D.		O.D.		Wt. Each	
	in.	mm	in.	mm	lbs.	kg
3/8	1 3/32	(10.32)	1 1/2	(38.10)	.03	(.01)
1/2	1 7/32	(13.49)	2	(50.80)	.03	(.01)

## TURNBUCKLE

**FIG. 960**

- Function:** Designed for use as a hanger rod connection on heavy loads when an adjustment of up to 6 (152.4) inches is required.  
**Material:** Forged steel (Type 316 Stainless Steel upon request)  
**Finish:** Plain or electro-galvanized (Hot dipped galvanized upon request)  
**Approvals:** Complies with Federal Specification A-A-1192A (Type 13) and Manufacturers' Standardization Society ANSI/MSS SP-58 (Type 13) which supersedes ANSI/MSS SP-69.  
**Ordering:** Specify figure number, rod size, and finish.

*NOTE: Openings of 3" (76.2), 9" (228.6) and 12" (304.8) are available upon request.*

Rod Size A	Max. Rec. Load				Wt. Each	
	650°F (343°C)		750°F (399°C)		lbs.	kg
	lbs.	kN	lbs.	kN		
3/8	730	(3.25)	572	(2.54)	.50	(.23)
1/2	1350	(6.01)	1057	(4.70)	.75	(.34)
5/8	2160	(9.61)	1692	(7.52)	1.12	(.51)
3/4	3230	(14.37)	2530	(11.25)	1.75	(.79)
7/8	4480	(19.93)	3508	(15.61)	1.83	(.83)
1	5900	(26.24)	4620	(20.55)	2.60	(1.18)
1 1/8	7450	(33.14)	5834	(25.95)	3.68	(1.67)
1 1/4	9500	(42.26)	7440	(33.09)	4.75	(2.15)
1 1/2	13800	(61.39)	10807	(48.07)	6.25	(2.83)

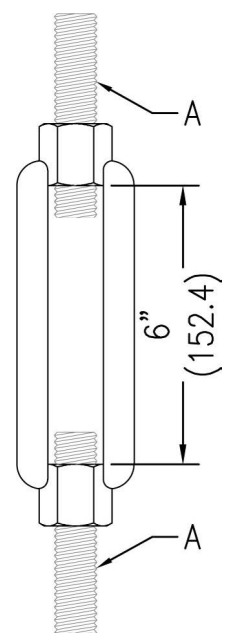

THREADED ACCESSORIES  
 CPVC STRAPS  
 BAND HANGERS  
 BEAM CLAMPS  
 CLEVIS HANGERS  
 PIPE ROLLER SUPPORTS  
 PIPE RING HANGERS  
 PIPE CLAMPS  
 CENTER LOAD BEAM CLAMPS  
 PIPE SHIELDS, INSULATION, & SADDLES  
 PIPE GUIDES & SLIDES  
 WALL BRACKETS  
 PIPE SUPPORTS  
 STRUCTURAL ATTACHMENTS  
 SEISMIC BRACING

**FIG. 070**

## CPVC TWO-HOLE PIPE STRAP

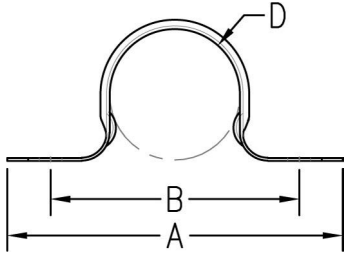

**Function:** Designed to support CPVC pipe horizontally from the side or bottom of beam. Fig. 070 can only be used as a guide on top of beam or on vertical piping. Fig. 070 also acts as a restrainer to prevent the thrust of a sprinkler head during activation when mounted on top of structure. Fig. 070 may be installed onto wood using supplied fasteners or into, minimum 20 gauge, steel using two 1/4" X 1" tek type screws (not included). Features flared edges to protect piping as it slides through the installed fitting and retaining dimples to allow for easy installation onto pipe.

**Size:** 3/4" (20) through 2" (50) CPVC pipe.

**Material:** Carbon Steel

**Finish:** Pre-galvanized

**Approvals:** Underwriters Laboratories listed for US and Canada.

**Ordering:** Specify figure number and pipe size.

Pipe Size		A		B		D Nominal		Box Qty.	Max. Spacing		Appx. Wt. Per 100	
									ft.	m	lbs.	kg
3/4	(20)	3 1/16	(77.79)	2 3/16	(55.56)	1.050	(26.67)	100	5.5	(1.68)	7.50	(3.40)
1	(25)	3 3/8	(85.73)	2 1/2	(63.50)	1.315	(33.40)	100	6	(1.83)	8.20	(3.72)
1 1/4	(32)	3 3/4	(95.25)	2 7/8	(73.03)	1.660	(42.16)	100	6.5	(1.98)	9.40	(4.26)
1 1/2	(40)	4 1/8	(104.78)	3 1/4	(82.55)	1.900	(48.26)	100	7	(2.13)	10.40	(4.72)
2	(50)	4 3/8	(111.13)	3 1/2	(88.90)	2.375	(60.33)	100	8	(2.44)	11.90	(5.40)

**FIG. 075**

## CPVC ONE-HOLE WRAP AROUND

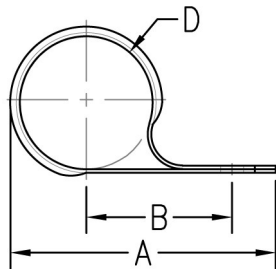

**Function:** Designed to support CPVC pipe horizontally from the side of a beam. Fig. 075 must be installed with the mounting tab oriented over top of piping on the side of a beam. Fig. 075 can only be used as a guide on top of beam or on vertical piping. Fig. 075 may be installed onto wood using supplied fasteners or into, minimum 20 gauge, steel using one 1/4" X 1" tek type screw (not included). Features flared edges to protect piping as it slides through the installed fitting.

**Size:** 3/4" (20) through 2" (50) CPVC pipe.

**Material:** Carbon Steel

**Finish:** Pre-galvanized

**Approvals:** Underwriters Laboratories listed for US and Canada.

**Ordering:** Specify figure number and pipe size.

Pipe Size		A		B		D Nominal		Box Qty.	Max. Spacing		Appx. Wt. Per 100	
									ft.	m	lbs.	kg
3/4	(20)	2 3/8	(60.33)	1 3/8	(34.93)	1.050	(26.67)	100	5.5	(1.68)	8.70	(3.95)
1	(25)	2 5/8	(66.68)	1 7/16	(36.51)	1.315	(33.40)	100	6	(1.83)	9.40	(4.26)
1 1/4	(32)	2 7/8	(73.03)	1 9/16	(39.69)	1.660	(42.16)	100	6.5	(1.98)	11.00	(4.99)
1 1/2	(40)	3 1/16	(77.79)	1 5/8	(41.28)	1.900	(48.26)	100	7	(2.13)	11.90	(5.40)
2	(50)	3 7/16	(87.31)	1 13/16	(46.04)	2.375	(60.33)	100	8	(2.44)	14.10	(6.40)



# CPVC STRAPS



## CPVC TWO-HOLE STAND OFF STRAP

**FIG. 076**

**Function:** Designed to support CPVC pipe horizontally from the side or bottom of beam, or composite wood joists with a minimum of  $\frac{3}{8}$ " web thickness. Fig. 076 can only be used as a guide on top of beam or on vertical piping. Fig. 076 may be installed onto wood using supplied fasteners. Intended for attachment to concrete, steel structural members, and sheet metal, with fasteners and fastening methods that comply with NFPA13 requirements. Features flared edges to protect piping as it slides through the installed fitting.

**Size:**  $\frac{3}{4}$ " (20) through 2" (50) CPVC pipe.  
**Material:** Carbon Steel  
**Finish:** Pre-galvanized  
**Approvals:** Underwriters Laboratories listed for US and Canada.  
**Ordering:** Specify figure number and pipe size.

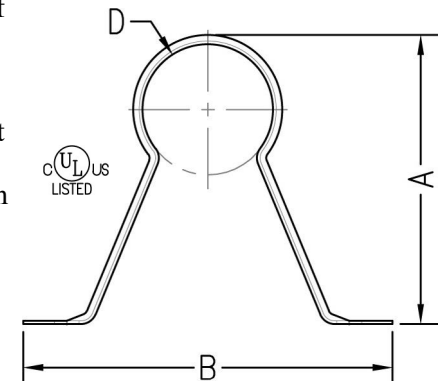

Pipe Size	A		B		D Nominal		Box Qty.	Max. Spacing		Appx. Wt. Per 100		
	in.	mm	in.	mm	in.	mm		ft.	m	lbs.	kg	
$\frac{3}{4}$	(20)	$2\frac{9}{16}$	(65.09)	$4\frac{1}{4}$	(107.95)	1.050	(26.67)	100	5.5	(1.68)	12.10	(5.49)
1	(25)	$2\frac{13}{16}$	(71.44)	$4\frac{1}{2}$	(114.30)	1.315	(33.40)	100	6	(1.83)	12.80	(5.81)
$1\frac{1}{4}$	(32)	$3\frac{3}{16}$	(80.96)	$4\frac{5}{8}$	(117.48)	1.660	(42.16)	100	6.5	(1.98)	14.10	(6.40)
$1\frac{1}{2}$	(40)	$3\frac{7}{16}$	(87.31)	5	(127.00)	1.900	(48.26)	100	7	(2.13)	15.20	(6.89)
2	(50)	$3\frac{7}{8}$	(98.43)	5	(127.00)	2.375	(60.33)	100	8	(2.44)	16.40	(7.44)

## CPVC TWO-HOLE SIDE MOUNT STRAP

**FIG. 077**

**Function:** Designed to support CPVC pipe horizontally from the side or bottom of beam. Fig. 077 can only be used as a guide on top of beam or on vertical piping. Fig. 077 also acts as a restrainer to prevent the thrust of a sprinkler head during activation when mounted on top of structure. Fig. 077 may be installed onto wood using supplied fasteners or into, minimum 20 gauge, steel using two  $\frac{1}{4}$ " X 1" tek type screws (not included). Features flared edges to protect piping and retaining dimples to allow for easy installation onto pipe.

**Size:**  $\frac{3}{4}$ " (20) through 2" (50) CPVC pipe.  
**Material:** Carbon Steel  
**Finish:** Pre-galvanized  
**Approvals:** Underwriters Laboratories listed for US and Canada.  
**Ordering:** Specify figure number and pipe size.

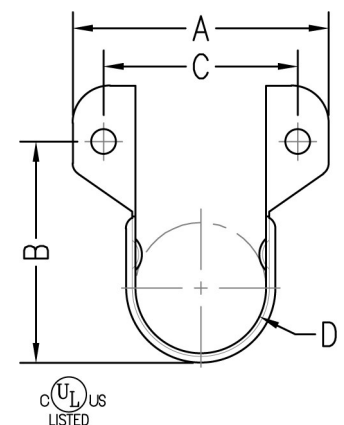

Pipe Size	A		B		C		D Nominal		Box Qty.	Max. Spacing		Appx. Wt. Per 100		
	in.	mm	in.	mm	in.	mm	in.	mm		ft.	m	lbs.	kg	
$\frac{3}{4}$	(20)	$2\frac{5}{16}$	(58.74)	$1\frac{7}{8}$	(47.63)	$1\frac{11}{16}$	(42.86)	1.050	(26.67)	100	5.5	(1.68)	8.50	(3.86)
1	(25)	$2\frac{9}{16}$	(65.09)	$2\frac{3}{16}$	(55.56)	$1\frac{5}{16}$	(49.21)	1.315	(33.40)	100	6	(1.83)	9.40	(4.26)
$1\frac{1}{4}$	(32)	$2\frac{15}{16}$	(74.61)	$2\frac{1}{2}$	(63.50)	$2\frac{5}{16}$	(58.74)	1.660	(42.16)	100	6.5	(1.98)	10.40	(4.72)
$1\frac{1}{2}$	(40)	$3\frac{1}{4}$	(82.55)	$2\frac{13}{16}$	(71.44)	$2\frac{5}{8}$	(66.68)	1.900	(48.26)	100	7	(2.13)	11.30	(5.13)
2	(50)	$3\frac{5}{8}$	(92.08)	$3\frac{1}{4}$	(82.55)	3	(76.20)	2.375	(60.33)	100	8	(2.44)	13.20	(5.99)

THREADED ACCESSORIES  
 CPVC STRAPS  
 BAND HANGERS  
 BEAM CLAMPS  
 CLEVIS HANGERS  
 PIPE ROLLER SUPPORTS  
 SPLIT RING HANGERS  
 PIPE CLAMPS  
 CENTER LOAD BEAM CLAMPS  
 PIPE SHIELDS, INSULATION, & SADDLES  
 PIPE GUIDES & SLIDES  
 WALL BRACKETS  
 PIPE SUPPORTS  
 STRUCTURAL ATTACHMENTS  
 SEISMIC BRACING



THIS PAGE IS  
INTENTIONALLY  
LEFT BLANK

# BAND HANGERS



## NFPA SWIVEL RING HANGER

## FIG. 141 & 141F

**Function:** Designed for the suspension of non-insulated stationary pipe lines. The knurled insert nut that allows a vertical adjustment after installation, is tapped to NFPA reduced rod size standards. Captured knurled insert nut present on pipe sizes 1/2" (15mm) to 2" (50mm). The capture is permanent in the bottom portion of the band, allowing the hanger to be opened during installation if desired, but preventing the knurled insert nut from falling completely out. Fig. 141F has a layer of felt which separates the pipe from the hanger to reduce vibration and sound.

**Material:** Carbon steel

**Finish:** Pre-galvanized (**Fig. 141**) or pre-galvanized with felt lining (**Fig. 141F**)

**Approvals:** Underwriters' Laboratories Listed in the U.S. (UL), Canada (CUL), for use with standard steel pipe sizes 3/4" (20mm) to 8" (200mm) and CPVC pipe size 3/4" (20mm) to 4" (100mm). Factory Mutual Approved for steel pipe sizes 3/4" (20mm) to 8" (200mm). Complies with Federal Specifications A-A-1192A (Type 10), and Manufacturers' Standardization Society ANSI/MSS SP-58 (Type 10) which supersedes ANSI/MSS SP-69.

**Ordering:** Specify figure number and pipe size.

**NOTE:** If ordering Fig. 141F felt lined hangers for pipe sizes of 3 1/2" (90mm) or under, order the next largest size to allow for the thickness of the felt lining. Metric knurl insert nuts available upon request.

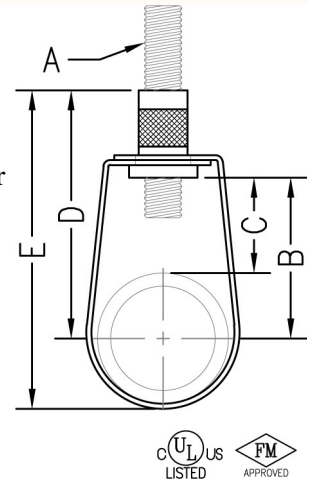

Pipe Size	Rod Size	B		Adj. C		D		E		Max. Rec. Load		Wt. Each		
										lbs.	kN	lbs.	kg	
1/2	(15)	3/8	1 7/8	(47.63)	1 7/16	(36.51)	2 3/4	(69.85)	3 1/16	(77.79)	300	(1.33)	.10	(.05)
3/4	(20)	3/8	1 11/16	(42.86)	1 1/8	(28.58)	2 1/2	(63.50)	3 1/16	(77.79)	300	(1.33)	.10	(.05)
1	(25)	3/8	1 5/8	(41.28)	1	(25.40)	2 1/2	(63.50)	3 3/16	(80.96)	300	(1.33)	.10	(.05)
1 1/4	(32)	3/8	1 15/16	(49.21)	1 1/16	(26.99)	2 13/16	(71.44)	3 9/16	(90.49)	300	(1.33)	.11	(.05)
1 1/2	(40)	3/8	2 1/8	(53.98)	1 1/16	(26.99)	3 1/8	(79.38)	3 7/8	(98.43)	300	(1.33)	.11	(.05)
2	(50)	3/8	2 7/16	(61.91)	1 1/8	(28.58)	3 5/16	(84.14)	4 3/8	(111.13)	300	(1.33)	.14	(.06)
2 1/2	(65)	3/8	3 1/16	(77.79)	1 5/8	(41.28)	3 15/16	(100.01)	5 3/8	(136.53)	525	(2.34)	.19	(.09)
3	(80)	3/8	3 11/16	(93.66)	1 7/8	(47.63)	4 9/16	(115.89)	6 5/16	(160.34)	525	(2.34)	.23	(.10)
3 1/2	(90)	3/8	3 3/4	(95.25)	1 7/8	(47.63)	4 5/8	(117.48)	6 5/8	(168.28)	525	(2.34)	.25	(.11)
4	(100)	3/8	4 3/16	(106.36)	1 7/8	(47.63)	5 1/16	(128.59)	7 5/16	(185.74)	650	(2.89)	.30	(.14)
5	(125)	1/2	4 5/8	(117.48)	1 5/8	(41.28)	5 5/8	(142.88)	8 3/8	(212.73)	1000	(4.45)	.50	(.23)
6	(150)	1/2	5 5/8	(142.88)	2 1/4	(57.15)	6 1/2	(165.10)	9 13/16	(249.24)	1000	(4.45)	.58	(.26)
8	(200)	1/2	6 13/16	(173.04)	2 7/16	(61.91)	7 15/16	(201.61)	12 1/4	(311.15)	1000	(4.45)	.90	(.41)

## SURGE RESTRAINT

## FIG. 055

**Function:** Designed to restrict the upward movement of activated fire sprinkler systems. Grips ring hanger, NOT THE NUT, and allows for fine tuning adjustments. Listed for use with PHD Manufacturing, Inc. Figure 141 ring hangers only.

**Material:** Spring Steel

**Finish:** Powder Coated

**Install:** Installs easily before or after pipe installation and without tools. Simply clip Fig. 055 onto Fig. 141 ring hanger and run the hanger rod down to the bottom plate surface to ensure proper restraint.

**Approvals:** Underwriters Laboratories listed for US and Canada.

**Ordering:** Specify figure number.

**NOTE:** For use up to 2" (50) pipe, one size fits all.

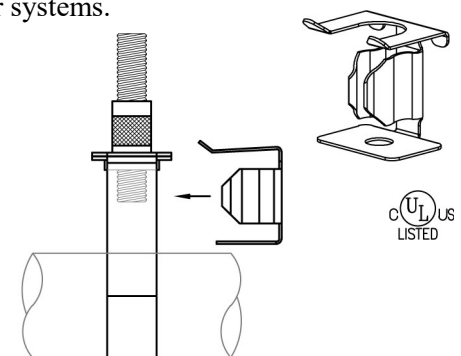
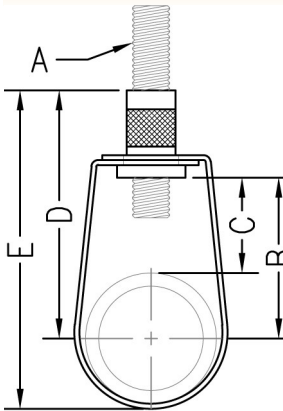

**Fig. 055**  
(Pictured With Fig. 141)

# BAND HANGERS

**FIG. 143**

## PVC COATED SWIVEL RING HANGER



**Function:** Designed for the suspension of non-insulated stationary pipe lines. The PVC coating on Fig. 143 protects the pipe from contact with the metal surface of the hanger. Frequently used with Aluminum, Glass, Plastic, Brass, or Copper pipe lines. This product is NOT compatible with CPVC pipe.

**Material:** Carbon steel

**Finish:** Pre-galvanized with PVC coating

**Approvals:** Underwriters' Laboratories Listed in the U.S. (UL), Canada (CUL), and Factory Mutual Approved for sizes  $\frac{3}{4}$ " (20mm) to 8" (200mm). Complies with Federal Specifications A-A-1192A (Type 10), and Manufacturers' Standardization Society ANSI/MSS SP-58 (Type 10) which supersedes ANSI/MSS SP-69.

**Ordering:** Specify figure number and pipe size.

*NOTE: Metric knurl insert nuts available upon request*

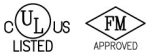

Pipe Size		Rod Size	B		Adj. C		D		E		Max. Rec. Load		Wt. Each	
											lbs.	kN	lbs.	kg
1/2	(15)	3/8	1 7/8	(47.63)	1 7/16	(36.51)	2 3/4	(69.85)	3 1/16	(77.79)	300	(1.33)	.11	(.05)
3/4	(20)	3/8	1 11/16	(42.86)	1 1/8	(28.58)	2 1/2	(63.50)	3 1/16	(77.79)	300	(1.33)	.13	(.06)
1	(25)	3/8	1 5/8	(41.28)	1	(25.40)	2 1/2	(63.50)	3 3/16	(80.96)	300	(1.33)	.13	(.06)
1 1/4	(32)	3/8	1 15/16	(49.21)	1 1/16	(26.99)	2 13/16	(71.44)	3 9/16	(90.49)	300	(1.33)	.15	(.07)
1 1/2	(40)	3/8	2 1/8	(53.98)	1 1/16	(26.99)	3 1/8	(79.38)	3 7/8	(98.43)	300	(1.33)	.17	(.08)
2	(50)	3/8	2 7/16	(61.91)	1 1/8	(28.58)	3 5/16	(84.14)	4 3/8	(111.13)	300	(1.33)	.18	(.08)
2 1/2	(65)	3/8	3 1/16	(77.79)	1 5/8	(41.28)	3 15/16	(100.01)	5 3/8	(136.53)	525	(2.34)	.19	(.09)
3	(80)	3/8	3 11/16	(93.66)	1 7/8	(47.63)	4 9/16	(115.89)	6 5/16	(160.34)	525	(2.34)	.23	(.10)
3 1/2	(90)	3/8	3 3/4	(95.25)	1 7/8	(47.63)	4 5/8	(117.48)	6 5/8	(168.28)	525	(2.34)	.25	(.11)
4	(100)	3/8	4 3/16	(106.36)	1 7/8	(47.63)	5 1/16	(128.59)	7 5/16	(185.74)	650	(2.89)	.30	(.14)
5	(125)	1/2	4 5/8	(117.48)	1 5/8	(41.28)	5 5/8	(142.88)	8 3/8	(212.73)	1000	(4.45)	.50	(.23)
6	(150)	1/2	5 5/8	(142.88)	2 1/4	(57.15)	6 1/2	(165.10)	9 13/16	(249.24)	1000	(4.45)	.58	(.26)
8	(200)	1/2	6 13/16	(173.04)	2 7/16	(61.91)	7 15/16	(201.61)	12 1/4	(311.15)	1000	(4.45)	.90	(.41)

# BAND HANGERS



## SWIVEL RING HANGER

**FIG. 151 & 151F**

**Function:** Designed for the suspension of non-insulated stationary pipe lines. The knurled insert nut, allows for vertical adjustment after installation. Fig. 151F has a layer of felt which separates the pipe from the hanger to reduce vibration and sound.

**Material:** Carbon steel

**Finish:** Pre-galvanized (**Fig. 151**) or pre-galvanized with felt lining (**Fig. 151F**)

**Approvals:** Underwriters' Laboratories Listed in the U.S. (UL) and Canada (CUL), and Factory Mutual Approved for all sizes. Complies with Federal Specification A-A-1192A (Type 10), and Manufacturers' Standardization Society ANSI/MSS SP-58 (Type 10) which supersedes ANSI/MSS SP-69.

**Ordering:** Specify figure number and pipe size.

*NOTE: If ordering Fig. 151F felt lined hangers for pipe sizes of 3 1/2" (90mm) or under, order the next largest size to allow for the thickness of the felt lining.*

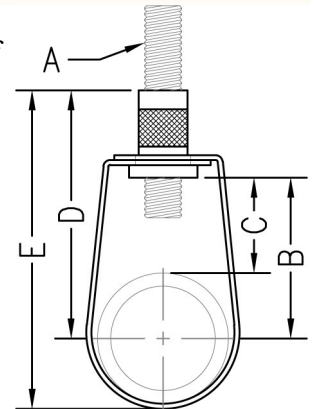

Pipe Size	Rod Size	B		Adj. C		D		E		Max. Rec. Load		Wt. Each	
		in	mm	in	mm	in	mm	in	mm	lbs.	kN	lbs.	kg
2 1/2	(65)	1/2	2 3/4 (69.85)	1 1/4	(31.75)	3 11/16	(93.66)	5 1/8	(130.18)	600	(2.67)	.33	(.15)
3	(80)	1/2	3 1/8 (79.38)	1 1/8	(28.58)	4	(101.60)	5 7/8	(149.23)	600	(2.67)	.35	(.16)
3 1/2	(90)	1/2	3 5/8 (92.08)	1 1/2	(38.10)	4 5/16	(109.54)	6 5/8	(168.28)	600	(2.67)	.37	(.17)
4	(100)	5/8	3 7/8 (98.43)	1 1/4	(31.75)	4 15/16	(125.41)	7 1/8	(180.98)	1000	(4.45)	.48	(.22)
5	(125)	5/8	3 3/8 (85.73)	1 3/8	(34.93)	5 5/8	(142.88)	8 1/2	(215.90)	1000	(4.45)	.57	(.26)
6	(150)	3/4	5 5/16 (134.94)	2	(50.80)	6 11/16	(169.86)	10 1/8	(257.18)	1250	(5.56)	1.06	(.48)
8	(200)	3/4	6 15/16 (176.21)	2 5/8	(66.68)	8 5/16	(211.14)	12 7/8	(327.03)	1250	(5.56)	1.32	(.60)

## COPPER TUBING SWIVEL RING HANGER

**FIG. 152 & 154**

**Function:** Designed for the suspension of non-insulated stationary copper tubing. The knurled insert allows for vertical adjustment after installation. The PVC coating on Fig. 154 protects the tubing from contact with the metal surface of the hanger.

**Material:** Carbon steel

**Finish:** Copper color epoxy (**Fig. 152**) Copper color epoxy with PVC coating (**Fig. 154**)

**Approvals:** Complies with Federal Specification A-A-1192A (Type 10) and Manufacturers' Standardization Society ANSI/MSS SP-58 (Type 10) which supersedes ANSI/MSS SP-69.

**Ordering:** Specify figure number and tube size.

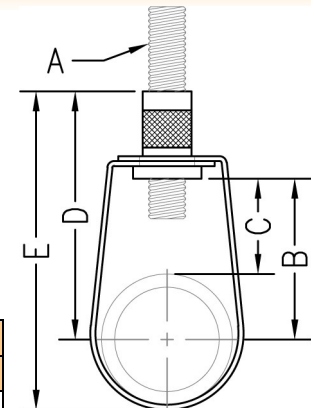

Tube Size	Rod Size	B		Adj. C		D		E		Max. Rec. Load		Wt. Each	
		in	mm	in	mm	in	mm	in	mm	lbs.	kN	lbs.	kg
1/2	(15)	3/8	1 13/16 (46.04)	1 1/2	(38.10)	2 11/16	(68.26)	3	(76.20)	300	(1.33)	.08	(.04)
3/4	(20)	3/8	1 5/8 (41.28)	1 3/16	(30.16)	2 1/2	(63.50)	2 15/16	(74.61)	300	(1.33)	.08	(.04)
1	(25)	3/8	1 9/16 (39.69)	1	(25.40)	2 9/16	(65.09)	3	(76.20)	300	(1.33)	.08	(.04)
1 1/4	(32)	3/8	1 5/8 (41.28)	1 5/16	(23.81)	2 1/2	(63.50)	3 3/16	(80.96)	300	(1.33)	.09	(.04)
1 1/2	(40)	3/8	1 11/16 (42.86)	7/8	(22.23)	2 9/16	(65.09)	3 3/8	(85.73)	300	(1.33)	.09	(.04)
2	(50)	3/8	2 7/16 (61.91)	1 3/8	(34.93)	3 5/16	(84.14)	4 3/8	(111.13)	300	(1.33)	.11	(.05)
2 1/2	(65)	3/8	2 13/16 (71.44)	1 1/2	(38.10)	3 7/8	(98.43)	5 9/16	(141.29)	525	(2.34)	.26	(.12)
3	(80)	3/8	3 1/8 (79.38)	1 9/16	(39.69)	4 3/16	(106.36)	5 3/4	(146.05)	525	(2.34)	.28	(.13)
3 1/2	(90)	3/8	3 1/2 (88.90)	1 11/16	(42.86)	4 9/16	(115.89)	6 3/8	(161.93)	525	(2.34)	.33	(.15)
4	(100)	3/8	3 3/4 (95.25)	1 11/16	(42.86)	4 13/16	(122.24)	6 15/16	(176.21)	650	(2.89)	.33	(.15)
5	(125)	1/2	4 1/8 (104.78)	1 9/16	(39.69)	5 3/16	(131.76)	7 13/16	(198.44)	1000	(4.45)	.56	(.25)
6	(150)	1/2	4 5/8 (117.48)	1 9/16	(39.69)	5 11/16	(144.46)	8 15/16	(227.01)	1000	(4.45)	.65	(.29)

Unless otherwise specified, all dimensions on drawings and in charts are in inches and dimensions shown in parentheses are in millimeters.

# BAND HANGERS

## FIG. 145 & 155 ADJUSTABLE SWIVEL RING HANGER WITH SECURED INSULATION SHIELD

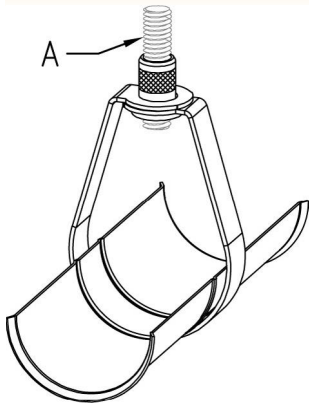

**Function:** Designed for the suspension of insulated pipe lines. Fig 145 is a combination of our Fig. 160 shield welded to a Fig. 141 hanger & the Fig 155 is a combination of our Fig. 160 shield welded to a Fig. 151 hanger, which ensures that the shield will be installed in conjunction with the hanger. Fig. 145 & 155 allows vertical adjustment after installation and offers maximum protection from crushing of the insulation by the hanger.

**Material:** Carbon steel

**Finish:** Pre-galvanized

**Ordering:** Specify figure number and size.

*NOTE: All shields furnished with flared ends. To determine proper size consult shield selection guide.*

Size No.	Rod Size A		Shield I.D.		Shield Length	Shield Gauge	Hanger Size	Max Rec. Load				Wt. Each					
	145	155						145		155		145		155			
	lbs.	kN	lbs.	kN	lbs.	kg	lbs.	kg									
1	3/8	3/8	23/8	(60.33)	8	(203.2)	18	2	(50)	300	(1.33)	300	(1.33)	.55	(.25)	.55	(.25)
2	3/8	1/2	25/8	(66.68)	8	(203.2)	18	2 1/2	(65)	525	(2.34)	600	(2.67)	.66	(.30)	.80	(.36)
3	3/8	1/2	27/8	(73.03)	8	(203.2)	18	2 1/2	(65)	525	(2.34)	600	(2.67)	.7	(.32)	.84	(.38)
4	3/8	1/2	3 1/2	(88.90)	8	(203.2)	18	3	(80)	525	(2.34)	600	(2.67)	.87	(.39)	.99	(.45)
5	3/8	1/2	4	(101.60)	8	(203.2)	18	3 1/2	(90)	525	(2.34)	600	(2.67)	1	(.45)	1.12	(.51)
6	3/8	5/8	4 1/2	(114.30)	8	(203.2)	18	4	(100)	650	(2.89)	1000	(4.45)	1.08	(.49)	1.26	(.57)
7	1/2	5/8	5	(127.00)	8	(203.2)	18	5	(125)	1000	(4.45)	1000	(4.45)	1.51	(.68)	1.58	(.72)
8	1/2	5/8	5 5/8	(142.88)	8	(203.2)	18	5	(125)	1000	(4.45)	1000	(4.45)	1.63	(.74)	1.70	(.77)
9	1/2	3/4	6	(152.40)	8	(203.2)	18	6	(150)	1000	(4.45)	1250	(5.56)	1.72	(.78)	2.20	(1.00)
10	1/2	3/4	6 5/8	(168.28)	8	(203.2)	18	6	(150)	1000	(4.45)	1250	(5.56)	1.87	(.85)	2.35	(1.07)
11	1/2	3/4	7 5/8	(193.68)	12	(304.8)	18	8	(200)	1000	(4.45)	1250	(5.56)	2.98	(1.35)	3.40	(1.54)
12	1/2	3/4	8 5/8	(219.08)	12	(304.8)	18	8	(200)	1000	(4.45)	1250	(5.56)	3.25	(1.47)	3.67	(1.66)

## FIG. 180, 180F, & 181

## BAND HANGER

**Function:** Designed for the suspension of non-insulated stationary pipe lines. Fig. 180F has a layer of felt which separates the pipe from the hanger to reduce vibration and sound.

**Material:** Carbon steel (Type 304 or 316 Stainless Steel upon request)

**Finish:** Plain (**Fig. 180**), plain with felt (**Fig. 180F**), or electro-galvanized (**Fig. 181**)

**Approvals:** Complies with Federal Specifications A-A-1192A (Type 7) and Manufacturers' Standardization Society ANSI/MSS SP-58 (Type 7), which supersedes ANSI/MSS SP-69.

**Ordering:** Specify figure number and pipe size.

*NOTE: Use of an upper locknut ensures proper performance. If ordering felt lined hangers for 3 1/2" (90) pipe or less, order the next largest size to allow for the thickness of the felt lining.*

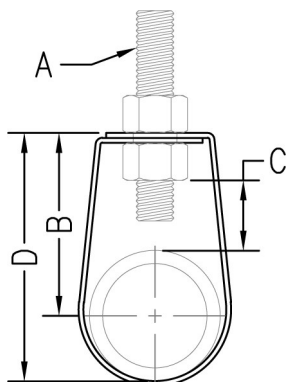

Pipe Size		Rod Size	B		Adj. C		D		Max. Rec. Load		Wt. Each	
									lbs.	kN	lbs.	kg
1/2	(15)	3/8	2 1/4	(57.15)	1 3/8	(34.93)	2 11/16	(68.26)	610	(2.71)	.13	(.06)
3/4	(20)	3/8	2 1/8	(53.98)	1 1/8	(28.58)	2 11/16	(68.26)	610	(2.71)	.13	(.06)
1	(25)	3/8	2 1/8	(53.98)	1 1/16	(26.99)	2 3/16	(71.44)	610	(2.71)	.14	(.06)
1 1/4	(32)	3/8	2 5/16	(58.74)	1	(25.40)	3 3/16	(80.96)	610	(2.71)	.16	(.07)
1 1/2	(40)	3/8	2 7/16	(61.91)	1 1/16	(26.99)	3 7/16	(87.31)	610	(2.71)	.18	(.08)
2	(50)	3/8	2 7/8	(73.03)	1 3/16	(30.16)	4 1/16	(103.19)	610	(2.71)	.20	(.09)
2 1/2	(65)	1/2	3 1/8	(79.38)	7/8	(22.23)	4 7/16	(112.71)	970	(4.31)	.37	(.17)
3	(80)	1/2	3 3/4	(95.25)	1 3/8	(34.93)	5 1/2	(139.70)	970	(4.31)	.43	(.20)
3 1/2	(90)	1/2	3 7/8	(98.43)	1 1/4	(31.75)	5 7/8	(149.23)	970	(4.31)	.47	(.21)
4	(100)	1/2	4 1/4	(107.95)	1 3/8	(34.93)	6 1/2	(165.10)	1250	(5.56)	.69	(.31)
5	(125)	1/2	4 13/16	(122.24)	1 1/2	(38.10)	7 5/8	(193.68)	1250	(5.56)	.82	(.37)
6	(150)	3/4	5 5/16	(150.81)	1 11/16	(42.86)	9 1/4	(234.95)	1600	(7.12)	1.50	(.68)
8	(200)	3/4	7 5/16	(201.61)	2 1/2	(63.50)	12 1/4	(311.15)	1800	(8.01)	1.89	(.86)

Unless otherwise specified, all dimensions on drawings and in charts are in inches and dimensions shown in parentheses are in millimeters.

# BAND HANGERS



## COPPER TUBING BAND HANGER

**FIG. 182**

**Function:** Designed for the suspension of non-insulated stationary copper tubing. When proper adjustment has been obtained, the hanger should be locked in place with an upper locknut.

**Material:** Carbon steel

**Finish:** Copper color epoxy finish

**Approvals:** Complies with Federal Specifications A-A-1192A (Type 7) and Manufacturers' Standardization Society ANSI/MSS SP-58 (Type 7) which supersedes ANSI/MSS SP-69.

**Ordering:** Specify figure number and pipe size.

*NOTE: Use of an upper locknut ensures proper performance.*

Tube Size	Rod Size	B		Adj. C		D		Max. Rec. Load		Wt. Each		
								lbs.	kN	lbs.	kg	
1/2	(15)	3/8	2 <sup>5</sup> / <sub>16</sub>	(58.74)	1 <sup>9</sup> / <sub>16</sub>	(39.69)	2 <sup>5</sup> / <sub>8</sub>	(66.68)	610	(2.71)	.12	(.05)
3/4	(19)	3/8	2 <sup>1</sup> / <sub>8</sub>	(53.98)	1 <sup>1</sup> / <sub>4</sub>	(31.75)	2 <sup>9</sup> / <sub>16</sub>	(65.09)	610	(2.71)	.12	(.05)
1	(25)	3/8	2	(50.80)	1	(25.40)	2 <sup>9</sup> / <sub>16</sub>	(65.09)	610	(2.71)	.12	(.05)
1 1/4	(32)	3/8	2 <sup>1</sup> / <sub>16</sub>	(52.39)	1 <sup>5</sup> / <sub>16</sub>	(23.81)	2 <sup>13</sup> / <sub>16</sub>	(71.44)	610	(2.71)	.13	(.06)
1 1/2	(40)	3/8	2 <sup>5</sup> / <sub>16</sub>	(58.74)	1 <sup>1</sup> / <sub>16</sub>	(26.99)	3 <sup>1</sup> / <sub>8</sub>	(79.38)	610	(2.71)	.14	(.06)
2	(50)	3/8	2 <sup>5</sup> / <sub>8</sub>	(66.68)	1 <sup>1</sup> / <sub>8</sub>	(28.58)	3 <sup>1</sup> / <sub>16</sub>	(93.66)	610	(2.71)	.16	(.07)
2 1/2	(65)	1/2	3 <sup>3</sup> / <sub>16</sub>	(80.96)	1 <sup>1</sup> / <sub>4</sub>	(31.75)	4 <sup>1</sup> / <sub>2</sub>	(114.30)	610	(2.71)	.28	(.13)
3	(80)	1/2	3 <sup>1</sup> / <sub>2</sub>	(88.90)	1 <sup>5</sup> / <sub>16</sub>	(33.34)	5	(127.00)	970	(4.31)	.35	(.16)
3 1/2	(90)	1/2	3 <sup>13</sup> / <sub>16</sub>	(96.84)	1 <sup>3</sup> / <sub>8</sub>	(34.93)	5 <sup>9</sup> / <sub>16</sub>	(141.29)	970	(4.31)	.46	(.21)
4	(100)	1/2	4	(101.60)	1 <sup>5</sup> / <sub>16</sub>	(33.34)	6 <sup>1</sup> / <sub>16</sub>	(153.99)	1130	(5.03)	.54	(.24)

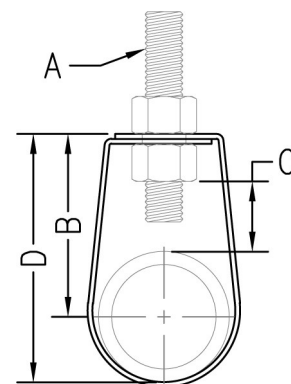

## TRH HANGING SYSTEM

**FIG. TRH 2 - TRH 5**

**Function:** Supports a pair of insulated flow and return refrigerant lines on 1/4" to 3/8" threaded rod. Simply fold the lock-tab over to secure the lines into the strap. The spring steel hanger grips the rod tightly, and the black zinc coating offers corrosion resistance while matching the insulation color. The clamp can be detached from the rod hanger and used to secure lines to flat surfaces.

**Material:** Spring Steel

**Finish:** Powder Coated

**Ordering:** Specify figure number.

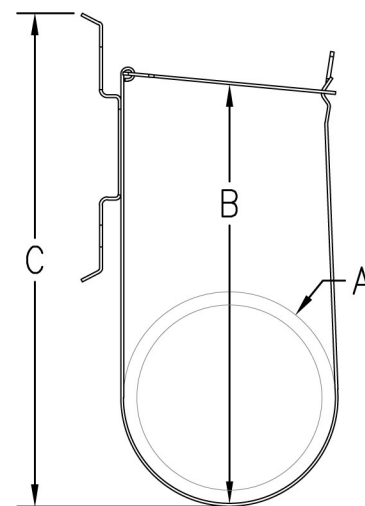
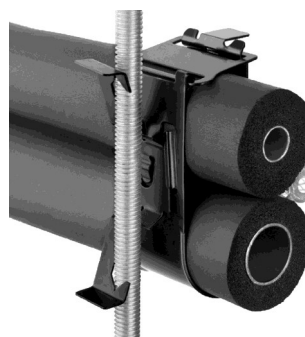

Fig. Number	Rod Size	A		B		C		Wt. Each	
								lbs.	kg
TRH 2	1/4 - 3/8	1.28	(32.51)	3.12	(79.25)	3.82	(97.03)	.148	(.07)
TRH 3	1/4 - 3/8	1.40	(35.56)	3.28	(83.31)	3.70	(93.98)	.152	(.07)
TRH 4	1/4 - 3/8	2.40	(60.96)	4.17	(105.92)	5.00	(127.00)	.209	(.09)
TRH 5	1/4 - 3/8	3.38	(85.85)	6.26	(159.00)	7.03	(178.56)	.316	(.14)

Unless otherwise specified, all dimensions on drawings and in charts are in inches and dimensions shown in parentheses are in millimeters.

# BEAM CLAMPS

**FIG. 250**

## STEEL C-CLAMP WITH LOCKNUT

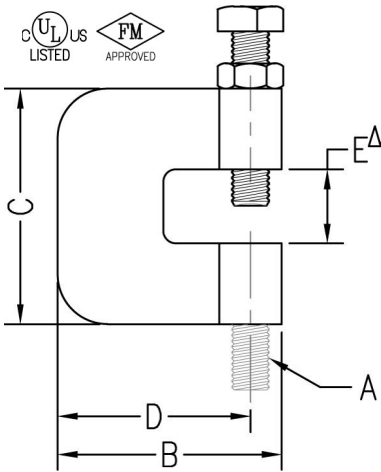

- Function:** Designed for attaching hanger rod to the bottom flange of a beam. The hanger rod should make contact with the beam flange to ensure full engagement.
- Material:** Carbon steel with hardened steel cup point set screw (Type 304 or 316 Stainless Steel upon request)
- Finish:** Plain or electro-galvanized
- Approvals:** Underwriters' Laboratories Listed in the U.S. (UL) and Canada (CUL) for  $3/8$ " and  $1/2$ " sizes only. Factory Mutual Approved for  $3/8$ " rod size only. Complies with Federal Specifications A-A-1192A (Type 23) and Manufacturers' Standardization Society ANSI/MSS SP-58 (Type 23) which supersedes ANSI/MSS SP-69. (Approvals are only for Fig. 250 with locknut).
- Ordering:** Specify figure number, rod size, material, and finish.

**NOTE:** When a torque wrench is unavailable, the setscrew should be tightened so it contacts the I-beam and then an additional  $1/4$  to  $1/2$  turn.

Set Screw Torque					
Nominal Thread Size	$3/8$	$5/8$	$3/4$	Caution should be taken not to over tighten the set screw	
Rec. Torque	in-lbs.	60	250		400
	N-m	(6.8)	(28.2)		(45.2)

Rod Size A	B	C	D	E <sup>A</sup>	Max. Pipe Size	Max. Rec. Load		Wt. Each			
						lbs.	kN	w/o nut		with nut	
								lbs.	kg	lbs.	lbs.
$3/8$	$2 1/4$ (57.15)	$2 3/8$ (60.33)	$7/8$ (22.23)	$3/4$ (19.05)	4 (100)	400 (1.78)	.36 (.16)	.38 (.17)	.38 (.17)	.38 (.17)	
$1/2$	$2 1/4$ (57.15)	$2 3/8$ (60.33)	$7/8$ (22.23)	$3/4$ (19.05)	4 (100)	500 (2.22)	.36 (.16)	.38 (.17)	.38 (.17)	.38 (.17)	
$5/8$	$2 3/8$ (60.33)	$2 3/8$ (60.33)	$3/4$ (19.05)	$3/4$ (19.05)	5 (125)	550 (2.45)	.63 (.29)	.68 (.31)	.68 (.31)	.68 (.31)	
$3/4$	$2 1/4$ (57.15)	$2 3/8$ (60.33)	$3/4$ (19.05)	$3/4$ (19.05)	6 (150)	600 (2.67)	.72 (.33)	.79 (.36)	.79 (.36)	.79 (.36)	
$7/8$	$3 1/4$ (57.15)	3 (76.20)	$1 1/4$ (31.75)	1 (25.40)	8 (200)	900 (4.00)	1.65 (.75)	1.83 (.83)	1.83 (.83)	1.83 (.83)	

<sup>A</sup> Reduced by  $1/8$ " (3.18mm) when used in conjunction with Fig. 259 retaining strap.

**FIG. 259**

## RETAINING STRAP (For Fig. 250 & 270)

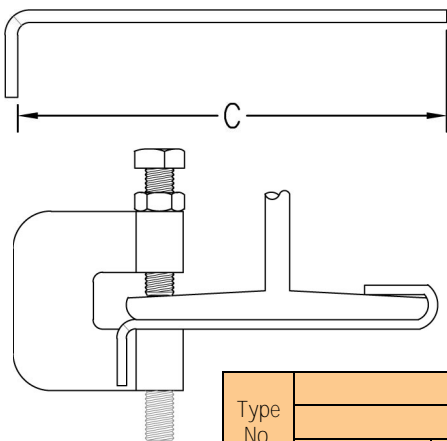

- Function:** Designed for use with Fig. 250 and 270 to eliminate possible movement of the beam clamp due to vibration.
- Material:** Carbon steel (Type 304 or 316 Stainless Steel upon request)
- Finish:** Plain or electro-galvanized
- Ordering:** Specify figure number, type number, length, material, and finish.

**NOTE:** 1" (25.4) should be added to beam flange width to determine length.

Type No.	Wt. Each											
	Length C											
	$4 1/2$ (114.3)	6 (152.4)	8 (203.2)	10 (254.0)	12 (304.8)	14 (355.6)						
1	.15 (3.81)	.22 (5.59)	.33 (8.38)	.36 (9.14)	.43 (10.92)	.50 (12.70)						
2	.21 (5.33)	.28 (7.11)	.36 (9.14)	.45 (11.43)	.52 (13.21)	.59 (14.99)						

Type No. Selection Chart		
Size	Model No.	
	250	270
$3/8$	1	2
$1/2$	1	2
$5/8$	1	2
$3/4$	1	2

Unless otherwise specified, all dimensions on drawings and in charts are in inches and dimensions shown in parentheses are in millimeters.



# BEAM CLAMPS



## MALLEABLE IRON C-CLAMP

**FIG. 270**

**Function:** Designed for attaching hanger rod to the bottom flange of a beam. The hanger rod should make contact with the beam flange to ensure full engagement.

**Material:** Malleable iron with hardened steel cup point set screw and locknut

**Finish:** Plain or electro-galvanized

**Approvals:** Complies with Federal Specifications A-A-1192A (Type 23) and Manufacturers' Standardization Society ANSI/MSS SPSP-58 (Type 23) which supersedes ANSI/MSS SP-69.

**Ordering:** Specify figure number, rod size, and finish.

*NOTE: When a torque wrench is unavailable, the setscrew should be tightened so it contacts the I-beam and then an additional 1/4 to 1/2 turn.*

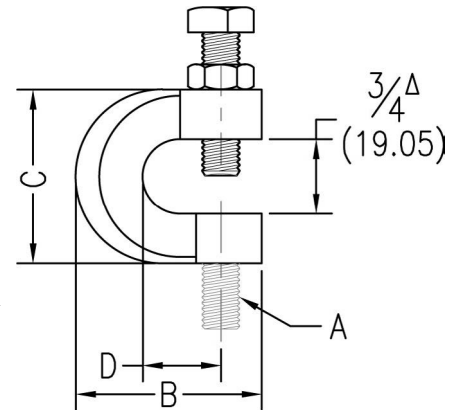

Set Screw Torque				Caution should be taken not to over tighten the set screw
Nominal Thread Size	3/8	1/2		
Rec. Torque	in-lbs.	60	125	
	N-m	(6.8)	(14.1)	

Rod Size A	B	C	D	Max. Pipe Size	Max. Rec. Load		Wt. Each	
					lbs.	kN	lbs.	kg
3/8	1 3/4 (44.45)	1 3/4 (44.45)	5/8 (15.88)	2 (50)	400	(1.78)	.33	(.15)
1/2	1 3/4 (44.45)	1 3/4 (44.45)	5/8 (15.88)	3 1/2 (90)	400	(1.78)	.39	(.18)
5/8	2 (50.80)	2 (50.80)	3/4 (19.05)	5 (125)	440	(1.96)	.46	(.21)
3/4	2 (50.80)	2 (50.80)	3/4 (19.05)	6 (150)	500	(2.22)	.52	(.24)

Δ Reduced by 1/8" (3.18mm) when used in conjunction with Fig. 259 retaining strap.

## PURLIN CLAMP

**FIG. 290**

**Function:** Designed for use with large-lip rolled steel purlins to eliminate the need to modify steel purlin for standard C-clamp.

**Material:** Malleable iron with hardened steel cup point set screw and locknut

**Finish:** Plain or electro-galvanized

**Approvals:** Underwriters' Laboratories Listed in the U.S. (UL) and Canada (CUL), and Factory Mutual Approved. Complies with Federal Specifications A-A-1192A (Type 23) and Manufacturers' Standardization Society ANSI/MSS SP-58 (Type 23) which supersedes ANSI/MSS SP-69.

**Ordering:** Specify figure number and finish.

*NOTE: When a torque wrench is unavailable, the setscrew should be tightened so it contacts the I-beam and then an additional 1/4 to 1/2 turn.*

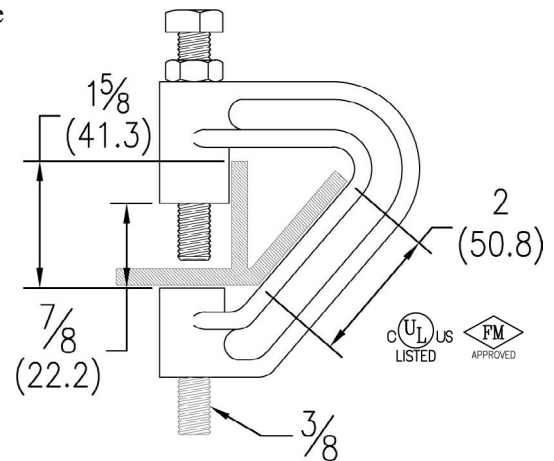

Set Screw Torque			Caution should be taken not to over tighten the set screw
Nominal Thread Size	3/8		
Rec. Torque	in-lbs.	60	
	N-m	(6.8)	

Rod Size	Max. Pipe Size	Max. Rec. Load		Wt. Each	
		lbs.	kN	lbs.	kg
3/8	4 (100)	400	(1.78)	.82	(.37)

THREADED ACCESSORIES  
CPVC STRAPS  
BAND HANGERS  
BEAM CLAMPS  
CLEVIS HANGERS  
PIPE ROLLER SUPPORTS  
PIPE RING HANGERS  
PIPE CLAMPS  
CENTER LOAD BEAM CLAMPS  
PIPE SHIELDS, INSULATION, & SADDLES  
PIPE GUIDES & SLIDES  
WALL BRACKETS  
PIPE SUPPORTS  
STRUCTURAL ATTACHMENTS  
SEISMIC BRACING

# BEAM CLAMPS

**FIG. 345**

## TOP BEAM CLAMP

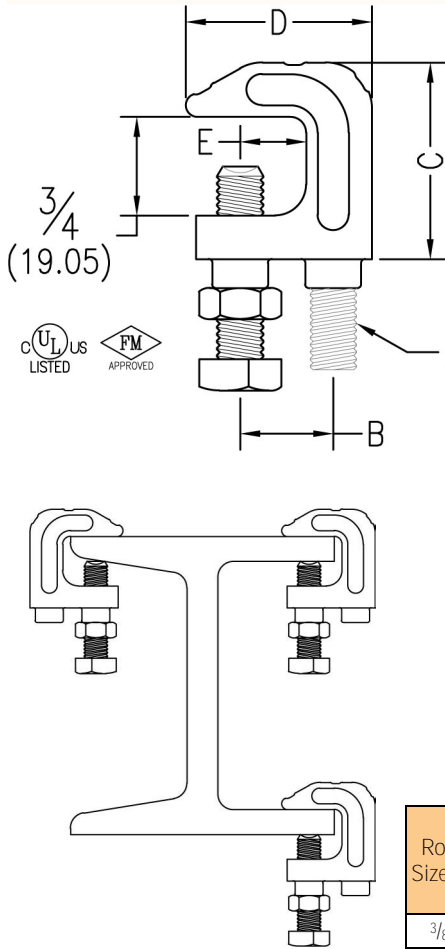

**Function:** Designed for attaching hanger rod to the top flange of a beam or bar joist where the flange thickness does not exceed  $\frac{3}{4}$ " (19.05mm). The open U design permits rod adjustment.

**Material:** Carbon steel with hardened steel cup point set screw and locknut

**Finish:** Pre-galvanized

**Approvals:** Underwriters' Laboratories Listed in the U.S. (UL), Canada (CUL) and Factory Mutual Approved. Complies with Federal Specifications A-A-1192A (Type 19) and Manufacturers' Standardization Society ANSI/MSS SP-58 (Type 19) which supersedes ANSI/MSS SP-69.

**Ordering:** Specify figure number.

**NOTE:** When a torque wrench is unavailable, the setscrew should be tightened so it contacts the I-beam and then an additional  $\frac{1}{4}$  to  $\frac{1}{2}$  turn. Set screw must contact the sloped side of the I-beam, channel, or other applicable building structure. Clamp must always be installed in top orientation, with the arrow mark on clamp pointing up. The following illustration displays the only acceptable installation positions. On parallel flange surfaces, the clamp may be attached to the upper or lower flange but must be in the top orientation as shown.

Set Screw Torque			Caution should be taken not to over tighten the set screw
Nominal Thread Size	$\frac{3}{8}$		
Rec. Torque	in-lbs.	60	
	N-m	(6.8)	

Rod Size A	B	C	D	E	Max. Pipe Size	Max. Rec. Load		Wt. Each with nut	
						lbs.	kN	lbs.	lbs.
$\frac{3}{8}$	$\frac{3}{4}$ (19.05)	$1\frac{1}{16}$ (39.69)	$1\frac{1}{2}$ (38.10)	$\frac{9}{16}$ (14.29)	4 (100)	610	(2.71)	.20	(.09)

**FIG. 358**

## RETROFIT RETAINING STRAP

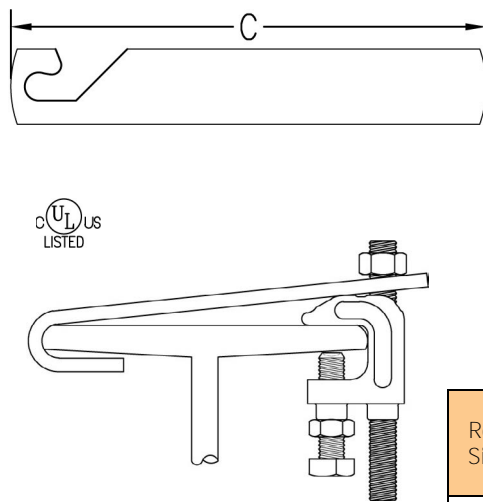

**Function:** Designed for use with Fig. 345, Fig. 350, and Fig. 360 to offer more secure fastening of beam clamps to beam where seismic protection is provided.

**Material:** Carbon steel (Type 304 or 316 Stainless Steel upon request)

**Finish:** Pre-galvanized

**Approvals:** Underwriters' Laboratories Listed in the U.S. (UL) and Canada (CUL) for  $\frac{3}{8}$ " and  $\frac{1}{2}$ " rod sizes only. Meets NFPA13 requirements for hangers and fasteners subject to earthquakes.

**Ordering:** Specify figure number, length, rod size, and material.

**NOTE:** Use jam nut over hanger rod to secure retaining strap. 2 inches (50.8) should be added to beam flange width to determine length.

Rod Size	Wt. Each									
	Length C									
	4 $\frac{1}{2}$ (114.3)	6 (152.4)	8 (203.2)	10 (254.0)	12 (304.8)	14 (355.6)	*16 (406.4)	*18 (457.2)		
$\frac{3}{8}$	.06 (.027)	.08 (.036)	.11 (.050)	.14 (.064)	.17 (.077)	.21 (.095)	.32 (.145)	.35 (.159)		
$\frac{1}{2}$	.06 (.027)	.08 (.036)	.11 (.050)	.14 (.064)	.17 (.077)	.20 (.091)	.32 (.145)	.35 (.159)		

\* Size Not UL Listed

# BEAM CLAMPS



## RETAINING STRAP (For Fig. 345, 350 & 360)

**FIG. 359**

**Function:** Designed for use with Fig. 345, Fig. 350, and Fig. 360 to offer more secure fastening of beam clamps to beam where seismic protection is provided.

**Material:** Carbon steel (Type 304 or 316 Stainless Steel upon request)

**Finish:** Pre-galvanized

**Approvals:** Underwriters' Laboratories Listed in the U.S. (UL) and Canada (CUL) for 3/8" and 1/2" rod sizes only. Meets NFPA13 requirements for hangers and fasteners subject to earthquakes.

**Ordering:** Specify figure number, length, rod size, and material.

*NOTE: Use jam nut over hanger rod to secure retaining strap. 2 inches (50.8) should be added to beam flange width to determine length.*

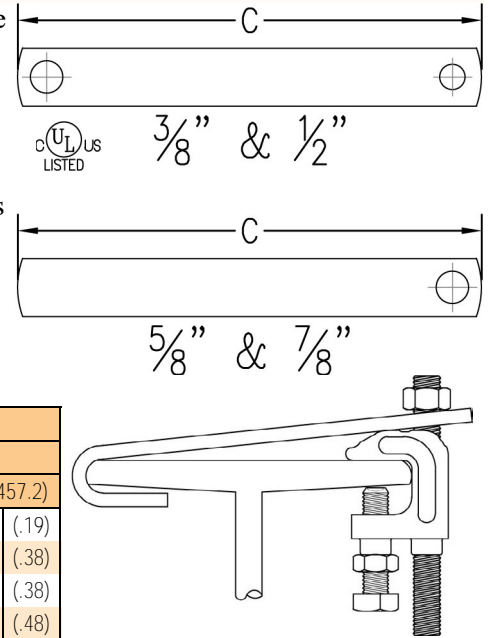

Rod Size	Wt. Each															
	Length C															
	4 1/2 (114.3)		6 (152.4)		8 (203.2)		10 (254.0)		12 (304.8)		14 (355.6)		*16 (406.4)		*18 (457.2)	
3/8 & 1/2	.09	(.04)	.12	(.05)	.15	(.07)	.21	(.10)	.22	(.10)	.29	(.13)	.38	(.17)	.42	(.19)
* 5/8	.19	(.09)	.25	(.11)	.34	(.15)	.42	(.19)	.50	(.23)	.59	(.27)	.74	(.33)	.83	(.38)
* 3/4	.19	(.09)	.25	(.11)	.33	(.15)	.41	(.19)	.49	(.22)	.57	(.26)	.74	(.33)	.83	(.38)
* 7/8	.28	(.23)	.37	(.17)	.50	(.23)	.62	(.28)	.75	(.34)	.87	(.39)	.94	(.43)	1.05	(.48)

\* Size Not UL Listed

## IMPORT BEAM CLAMP

**FIG. 350**

**Function:** Designed for attaching hanger rod to the top flange of a beam or bar joist, where the flange thickness does not exceed 3/4 inch (19.05mm). The open U design permits rod adjustment.

**Material:** Malleable iron with hardened steel cup point set screw and locknut (Type 304 or 316 Stainless Steel upon request for 1/4", 3/8", and 1/2" only)

**Finish:** Plain or electro-galvanized

**Approvals:** Underwriters' Laboratories Listed in the U.S. (UL), Canada (CUL), for sizes 3/8" to 7/8" malleable iron only. Factory Mutual Approved for rod size 3/8" & 1/2" malleable iron only. Complies with Federal Specifications A-A-1192A (Type 19) and Manufacturers' Standardization Society ANSI/MSS SPSP-58 (Type 19) which supersedes ANSI/MSS SP-69. (Approvals are only valid for beam clamps with locknut).

**Ordering:** Specify figure number, rod size, material, and finish.

*NOTE: When a torque wrench is unavailable, the setscrew should be tightened so it contacts the I-beam and then an additional 1/4 to 1/2 turn.*

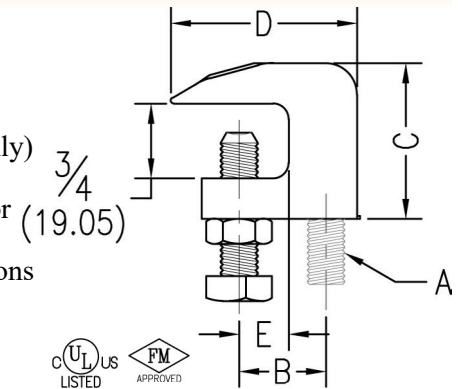

Set Screw Torque				Caution should be taken not to over tighten the set screw
Nominal Thread Size	3/8	1/2		
Rec. Torque	in-lbs. 60	125		
	N-m (6.8)	(14.1)		

Rod Size A	B	C	D	E	Max. Pipe Size	Max. Rec. Load		Wt. Each						
						lbs.	kN	lbs.	kg					
* 1/4	7/8	(22.23)	1 1/2	(38.10)	1 5/8	(41.28)	1/2	(12.70)	N/A	N/A	250	(1.11)	.34	(.15)
▲ 3/8	7/8	(22.23)	1 1/2	(38.10)	1 5/8	(41.28)	1/2	(12.70)	4	(100)	400	(1.78)	.33	(.15)
1/2	1	(25.40)	1 1/2	(38.10)	1 11/16	(42.86)	1/2	(12.70)	8	(200)	500	(2.22)	.34	(.15)
5/8	1 1/16	(26.99)	1 1/2	(38.10)	1 7/8	(47.63)	5/8	(15.88)	8	(200)	600	(2.67)	.39	(.18)
3/4	1 5/16	(33.34)	1 3/4	(44.45)	2 3/8	(60.33)	5/8	(15.88)	8	(200)	800	(3.56)	.63	(.29)
7/8	1 5/16	(33.34)	1 3/4	(44.45)	2 3/8	(60.33)	5/8	(15.88)	8	(200)	1200	(5.34)	.60	(.27)

\* 1/4" Not UL or FM approved. Available in type 304 or 316 stainless steel only. For non stainless steel 1/4" rod sizes, see Fig. 350 - 1/4" Malleable Domestic Beam Clamp.

▲ 3/8" Fig. 350 Reversible design approved for bottom beam use.

Unless otherwise specified, all dimensions on drawings and in charts are in inches and dimensions shown in parentheses are in millimeters.

THREADED ACCESSORIES  
CPVC STRAPS  
BAND HANGERS  
BEAM CLAMPS  
CLEVIS HANGERS  
PIPE ROLLER SUPPORTS  
SPLIT RING HANGERS  
PIPE CLAMPS  
CENTER LOAD BEAM CLAMPS  
PIPE SHIELDS, INSULATION, & SADDLES  
PIPE GUIDES & SLIDES  
WALL BRACKETS  
PIPE SUPPORTS  
STRUCTURAL ATTACHMENTS  
SEISMIC BRACING

# BEAM CLAMPS

**FIG. 360**

## IMPORT WIDE MOUTH BEAM CLAMP

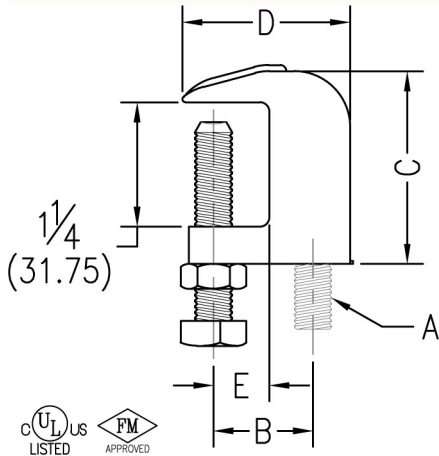

**Function:** Designed for attaching hanger rod to the top flange of a beam or bar joist, where the flange thickness does not exceed 1 1/4" (31.75mm). The open U design permits rod adjustment.

**Material:** Malleable iron with hardened steel cup point set screw and locknut

**Finish:** Plain or electro-galvanized

**Approvals:** Underwriters' Laboratories Listed in the U.S. (UL), Canada (CUL), and Factory Mutual Approved for rod sizes 3/8" and 1/2" only. Complies with Federal Specifications A-A-1192A (Type 19) and Manufacturers' Standardization Society ANSI/MSS SP-58 (Type 19) which supersedes ANSI/MSS SP-69. (Approvals are only valid for beam clamps with locknut).

**Ordering:** Specify figure number, rod size, and finish.

**NOTE:** When a torque wrench is unavailable, the setscrew should be tightened so it contacts the I-beam and then an additional 1/4 to 1/2 turn.

Set Screw Torque			Caution should be taken not to over tighten the set screw
Nominal Thread Size	3/8		
Rec. Torque	in-lbs.	60	
	N-m	(6.8)	

Rod Size A	B		C		D		E		Max. Pipe Size		Max. Rec. Load		Wt. Each	
		(mm)		(mm)		(mm)		(mm)		(mm)	lbs.	kN	lbs.	kg
3/8	1	(25.40)	1 7/8	(47.63)	1 5/8	(41.28)	1/2	(12.70)	4	(100)	400	(1.78)	.37	(.17)
1/2	1	(25.40)	1 7/8	(47.63)	1 5/8	(41.28)	1/2	(12.70)	8	(200)	500	(2.22)	.35	(.16)
5/8	1 3/8	(34.93)	2 5/16	(58.74)	2 1/4	(57.15)	3/4	(19.05)	8	(200)	850	(3.78)	.74	(.34)
3/4	1 1/2	(38.10)	2 3/8	(60.33)	2 3/8	(60.33)	3/4	(19.05)	8	(200)	900	(4.00)	.87	(.39)

# BEAM CLAMPS



## DOMESTIC BEAM CLAMP FIG. 350, 353, 354, 355, 356, & 357

**Function:** Designed for attaching hanger rod to the top flange of a beam or bar joist, where the flange thickness does not exceed  $\frac{3}{4}$ " (19.05mm). The open U design permits rod adjustment. The universal design of the  $\frac{3}{8}$ " Fig. 353 allows it to be used in an inverted position on the bottom flange of a beam as well.

**Material:** Malleable iron with hardened steel cup point set screw and locknut  
**Finish:** Plain or electro-galvanized (Hot dipped galvanized with electro-galvanized hardware upon request)

**Approvals:** Underwriters' Laboratories Listed in the U.S. (UL), Canada (CUL), for sizes  $\frac{3}{8}$ " to  $\frac{7}{8}$ " only. Factory Mutual Approved for rod sizes  $\frac{3}{8}$ " and  $\frac{1}{2}$ " only. Complies with Federal Specifications A-A-1192A (Type 19) and Manufacturers' Standardization Society ANSI/MSS SPSP-58 (Type 19) which supersedes ANSI/MSS SP-69. Fig. 353 sized for  $\frac{3}{8}$ " rod can be used in an inverted position (bottom of beam) and follows the same U.S. (UL), Canada (CUL), and Factory Mutual Approvals. Used in this manner the  $\frac{3}{8}$ " Fig. 353 also complies with Federal Specifications A-A-1192A (Type 23) and Manufacturers' Standardization Society ANSI/MSS SPSP-58 (Type 23) which supersedes ANSI/MSS SP-69. (Approvals are only valid for beam clamps with locknut). Buy American Act compliant

**Ordering:** Specify figure number, rod size, and finish.

**NOTE:** When a torque wrench is unavailable, the setscrew should be tightened so it contacts the I-beam and then an additional  $\frac{1}{4}$  to  $\frac{1}{2}$  turn.

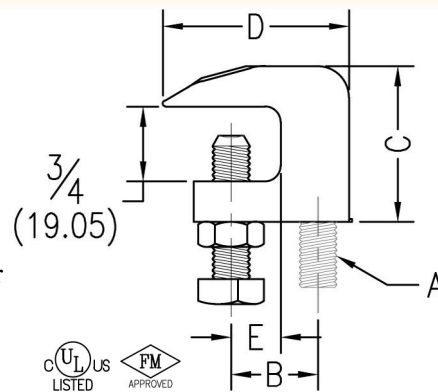

Set Screw Torque				Caution should be taken not to over tighten the set screw
Nominal Thread Size	$\frac{3}{8}$	$\frac{1}{2}$		
Rec. Torque	in-lbs.	60	125	
	N-m	(6.8)	(14.1)	

Figure Numbers	Rod Size A	B		C		D		E		Max. Pipe Size		Max. Rec. Load		Wt. Each	
			(mm)		(mm)		(mm)		(mm)		(in)	lbs.	kN	lbs.	kg
* 350	$\frac{1}{4}$	$\frac{7}{8}$	(22.23)	$1\frac{1}{2}$	(38.10)	$1\frac{5}{8}$	(41.28)	$\frac{1}{2}$	(12.70)	N/A	N/A	250	(1.11)	.34	(.15)
$\Delta$ 353	$\frac{3}{8}$	$\frac{7}{8}$	(22.23)	$1\frac{1}{2}$	(38.10)	$1\frac{5}{8}$	(41.28)	$\frac{1}{2}$	(12.70)	4	(100)	400	(1.78)	.33	(.15)
354	$\frac{1}{2}$	1	(25.40)	$1\frac{1}{2}$	(38.10)	$1\frac{11}{16}$	(42.86)	$\frac{1}{2}$	(12.70)	8	(200)	500	(2.22)	.34	(.15)
355	$\frac{5}{8}$	$1\frac{1}{16}$	(26.99)	$1\frac{1}{2}$	(38.10)	$1\frac{7}{8}$	(47.63)	$\frac{5}{8}$	(15.88)	8	(200)	600	(2.67)	.39	(.18)
356	$\frac{3}{4}$	$1\frac{5}{16}$	(33.34)	$1\frac{3}{4}$	(44.45)	$2\frac{3}{8}$	(60.33)	$\frac{5}{8}$	(15.88)	8	(200)	800	(3.56)	.63	(.29)
357	$\frac{7}{8}$	$1\frac{5}{16}$	(33.34)	$1\frac{3}{4}$	(44.45)	$2\frac{3}{8}$	(60.33)	$\frac{5}{8}$	(15.88)	8	(200)	1200	(5.34)	.60	(.27)

\*  $\frac{1}{4}$ " Fig. 350 Not UL or FM approved.

$\Delta$   $\frac{3}{8}$ " Fig. 353 Reversible design approved for bottom beam use.

THREADED ACCESSORIES  
 CPVC STRAPS  
 BAND HANGERS  
 BEAM CLAMPS  
 CLEVIS HANGERS  
 PIPE ROLLER SUPPORTS  
 PIPE RING HANGERS  
 SPLIT RING HANGERS  
 PIPE CLAMPS  
 CENTER LOAD BEAM CLAMPS  
 PIPE SHIELDS, INSULATION, & SADDLES  
 PIPE GUIDES & SLIDES  
 WALL BRACKETS  
 PIPE SUPPORTS  
 STRUCTURAL ATTACHMENTS  
 SEISMIC BRACING

# BEAM CLAMPS

**FIG. 363 & 364**

## DOMESTIC WIDE MOUTH BEAM CLAMP

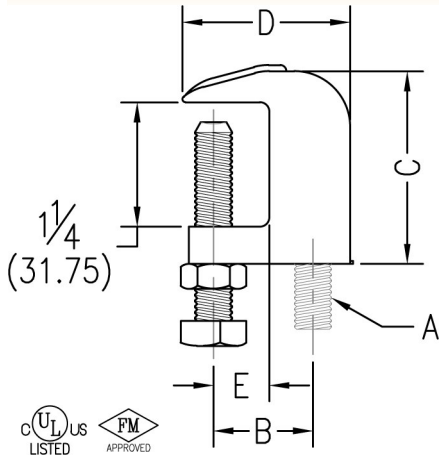

**Function:** Designed for attaching hanger rod to the top flange of a beam or bar joist, where the flange thickness does not exceed 1 1/4" (31.75mm). The open U design permits rod adjustment.

**Material:** Malleable iron with hardened steel cup point set screw and locknut

**Finish:** Plain or electro-galvanized (Hot dipped galvanized with electro-galvanized hardware upon request)

**Approvals:** Underwriters' Laboratories Listed in the U.S. (UL), Canada (CUL), and Factory Mutual Approved for rod sizes. Complies with Federal Specifications A-A-1192A (Type 19) and Manufacturers' Standardization Society ANSI/MSS SP-58 (Type 19) which supersedes ANSI/MSS SP-69. (Approvals are only valid for beam clamps with locknut). Buy American Act compliant

**Ordering:** Specify figure number, rod size, and finish.

**NOTE:** When a torque wrench is unavailable, the setscrew should be tightened so it contacts the I-beam and then an additional 1/4 to 1/2 turn.

Set Screw Torque		
Nominal Thread Size	3/8	Caution should be taken not to over tighten the set screw
Rec. Torque	in-lbs. 60 N-m (6.8)	

Figure Numbers	Rod Size A	B		C		D		E		Max. Pipe Size		Max. Rec. Load		Wt. Each	
		in.	mm	in.	mm	in.	mm	in.	mm	in.	mm	lbs.	kN	lbs.	kg
363	3/8	1	(25.40)	1 7/8	(47.63)	1 5/8	(41.28)	1/2	(12.70)	4	(100)	400	(1.78)	.37	(.17)
364	1/2	1	(25.40)	1 7/8	(47.63)	1 5/8	(41.28)	1/2	(12.70)	8	(200)	500	(2.22)	.35	(.16)

# CLEVIS HANGERS



## A.W.W.A CLEVIS HANGER

**FIG. 420**

- Function:** Designed for the suspension of stationary (A.W.W.A.) ductile iron and cast iron pipe.
- Material:** Carbon steel (Type 304 or 316 Stainless Steel upon request)
- Finish:** Plain or electro-galvanized (Hot dipped galvanized with electro-galvanized hardware upon request)
- Approvals:** Complies with Federal Specifications A-A-1192A (Type 1) and Manufacturers' Standardization Society ANSI/MSS SP-58 (Type 1) which supersedes ANSI/MSS SP-69.
- Ordering:** Specify figure number, A.W.W.A. pipe size, material, and finish.

*NOTE: Use of an upper locknut ensures proper performance. For sizes of 10" (250) and larger, a pipe spacer is added over the cross bolt.*

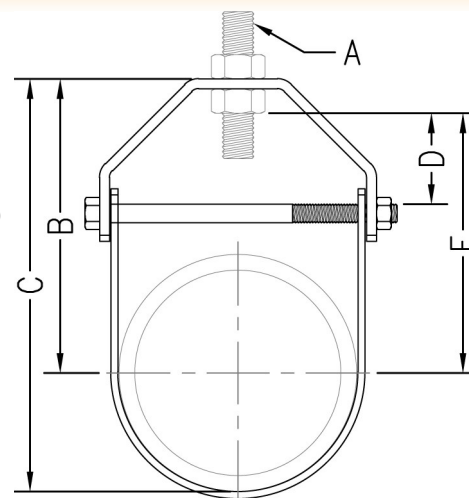

A.W.W.A. Pipe Size		Pipe O.D.		Rod Size A	B		C		Adjustment D		E		Cross Bolt	Max. Rec. Load		Wt. Each	
														lbs.	kN	lbs.	kg
3	(80)	3.96	(100.58)	1/2	4 1/2	(114.30)	6 1/2	(165.10)	1 1/4	(31.75)	3 7/8	(98.43)	3/8	1350	(6.01)	1.22	(.55)
4	(100)	4.80	(121.92)	5/8	5 3/4	(146.05)	8 1/8	(206.38)	1 3/8	(34.93)	4 5/8	(117.48)	3/8	1430	(6.36)	2.08	(.94)
6	(150)	6.90	(175.26)	3/4	6 15/16	(176.21)	10 3/8	(263.53)	1 3/8	(34.93)	5 5/8	(142.88)	1/2	1940	(8.63)	2.78	(1.26)
8	(200)	9.05	(229.87)	3/4	9 1/4	(234.95)	13 3/4	(349.25)	2 1/2	(63.50)	7 7/8	(200.03)	5/8	2000	(8.90)	4.47	(2.03)
10	(250)	11.10	(281.94)	7/8	11 1/8	(282.58)	16 5/8	(422.28)	2 1/2	(63.50)	9 5/8	(244.48)	3/4	3600	(16.01)	8.87	(4.02)
12	(300)	13.20	(335.28)	7/8	12 5/8	(320.68)	19 1/4	(488.95)	2 7/8	(73.03)	11 1/8	(282.58)	3/4	3800	(16.90)	12.03	(5.46)
14	(350)	15.30	(388.62)	1	14 1/8	(358.78)	21 3/4	(552.45)	3 1/8	(79.38)	12 3/8	(314.33)	7/8	4200	(18.68)	15.15	(6.87)
16	(400)	17.40	(441.96)	1	14 7/8	(377.83)	23 5/8	(600.08)	2 3/4	(69.85)	13 1/8	(333.38)	1	4600	(20.46)	23.61	(10.71)
18	(450)	19.50	(495.30)	1	16 1/2	(419.10)	26 1/4	(666.75)	3 1/4	(82.55)	14 5/8	(371.48)	1 1/8	4800	(21.35)	25.90	(11.75)
20	(500)	21.60	(548.64)	1 1/4	18 11/16	(474.66)	29 1/2	(749.30)	3 5/8	(92.08)	16 13/16	(427.04)	1 1/4	4800	(21.35)	44.30	(20.09)
24	(600)	25.80	(655.32)	1 1/4	21 13/16	(554.04)	34 3/4	(882.65)	4 5/8	(117.48)	19 15/16	(506.41)	1 1/4	4800	(21.35)	52.45	(23.79)
30	(750)	32.00	(812.80)	1 1/4	33 1/2	(850.90)	46 1/2	(1181.10)	6 1/2	(165.10)	30 3/8	(771.53)	1 1/4	4800	(21.35)	76.90	(34.88)
36	(900)	38.30	(972.82)	1 1/2	38 1/8	(968.38)	53 1/4	(1352.55)	7 1/4	(184.15)	31 1/4	(793.75)	1 1/2	7000	(31.14)	202.00	(91.63)

Adjustment "D" (Top of cross bolt to bottom of hanger rod nut.)

THREADED ACCESSORIES  
CPVC STRAPS  
BAND HANGERS  
BEAM CLAMPS  
CLEVIS HANGERS  
PIPE ROLLER SUPPORTS  
SPLIT RING HANGERS  
PIPE CLAMPS  
CENTER LOAD BEAM CLAMPS  
PIPE SHIELDS, INSULATION, & SADDLES  
PIPE GUIDES & SLIDES  
WALL BRACKETS  
PIPE SUPPORTS  
STRUCTURAL ATTACHMENTS  
SEISMIC BRACING

# CLEVIS HANGERS

**FIG. 425 & 426**

## STAINLESS STEEL CLEVIS HANGER

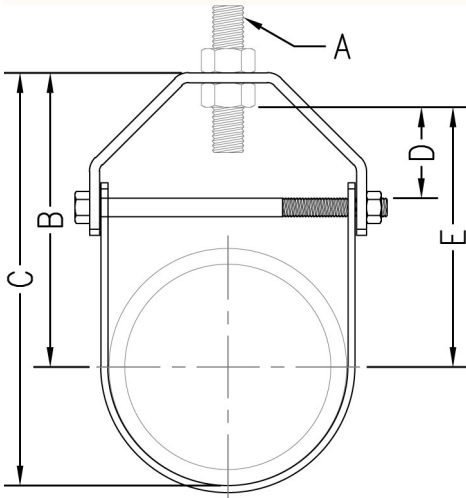

**Function:** Designed for the suspension of non-insulated stationary pipe lines in applications where protection from corrosive environments is desired. Frequently specified for areas requiring the ultimate in sanitation. Another benefit includes a reduction of long term maintenance costs, due to the corrosive resistant properties of stainless steel.

**Material:** Type 304 stainless steel (**Fig. 425**) or type 316 stainless steel (**Fig. 426**)

**Finish:** Plain

**Approvals:** Complies with Federal Specification A-A-1192A (Type 1) and Manufacturers' Standardization Society ANSI/MSS SP-58 (Type 1) which supersedes ANSI/MSS SP-69.

**Ordering:** Specify figure number and pipe size.

**NOTE:** Use of an upper locknut ensures proper performance. Pipe spacers provided on 30" (750mm) and larger clevises. When an over-sized clevis is used, a pipe spacer should be placed over the clevis bolt to prevent the lower U-strap from moving inward.

Pipe Size		Rod Size A	B		C		Adjustment D		E		Cross Bolt	Max. Rec. Load		Wt. Each	
												lbs.	kN	lbs.	kg
1/2	(15)	3/8	2 7/16	(61.9)	2 7/8	(73.0)	1 1/8	(28.6)	2	(50.8)	1/4	730	(3.25)	0.24	(0.11)
3/4	(20)	3/8	2 5/8	(66.7)	3 1/8	(79.4)	1 1/4	(31.8)	2 3/16	(55.6)	1/4	730	(3.25)	0.24	(0.11)
1	(25)	3/8	3 1/16	(77.8)	3 3/4	(95.3)	1 5/8	(41.3)	2 5/8	(66.7)	1/4	730	(3.25)	0.28	(0.13)
1 1/4	(32)	3/8	3 3/8	(85.7)	4 3/16	(106.4)	1 5/8	(41.3)	2 15/16	(74.6)	1/4	730	(3.25)	0.32	(0.15)
1 1/2	(40)	3/8	3 1/2	(88.9)	4 7/16	(112.7)	1 1/2	(38.1)	3 1/16	(77.8)	1/4	730	(3.25)	0.40	(0.18)
2	(50)	3/8	3 3/4	(95.3)	5	(127.0)	1 5/8	(41.3)	3 5/16	(84.1)	1/4	730	(3.25)	0.52	(0.24)
2 1/2	(65)	1/2	4 5/8	(117.5)	6 1/16	(154.0)	2	(50.8)	4 1/16	(103.2)	3/8	1350	(6.01)	0.72	(0.33)
3	(80)	1/2	4 7/8	(123.8)	6 5/8	(168.3)	1 13/16	(46.0)	4 1/4	(108.0)	3/8	1350	(6.01)	0.78	(0.35)
3 1/2	(90)	1/2	4 1/2	(114.3)	6 1/2	(165.1)	1 1/4	(31.8)	3 7/8	(98.4)	3/8	1350	(6.01)	1.16	(0.53)
4	(100)	5/8	5 1/2	(139.7)	7 1/16	(195.3)	1 3/4	(44.5)	4 11/16	(119.1)	3/8	1430	(6.36)	1.35	(0.61)
5	(125)	5/8	6 1/8	(155.6)	9 1/8	(231.8)	1 7/8	(47.6)	5 5/16	(134.9)	1/2	1430	(6.36)	1.88	(0.85)
6	(150)	3/4	6 7/8	(174.6)	10 1/8	(257.2)	1 5/8	(41.3)	6	(152.4)	1/2	1940	(8.63)	2.76	(1.25)
8	(200)	3/4	8 3/4	(222.3)	12 7/8	(327.0)	2 1/8	(54.0)	7 7/8	(200.0)	5/8	2000	(8.90)	4.35	(1.97)
10	(250)	7/8	10 3/8	(263.5)	15 3/4	(400.1)	2 3/8	(60.3)	9 1/8	(231.8)	3/4	3600	(16.01)	8.22	(3.73)
12	(300)	7/8	11 5/8	(295.3)	18	(457.2)	2 1/2	(63.5)	10 1/2	(266.7)	3/4	3800	(16.90)	10.05	(4.56)
14	(350)	1	12 3/4	(323.9)	19 3/4	(501.7)	2 5/8	(66.7)	11 1/4	(285.8)	7/8	4200	(18.68)	12.97	(5.88)
16	(400)	1	14 1/8	(358.8)	22 7/8	(562)	2 5/8	(66.7)	13 5/8	(346.1)	1	4600	(20.46)	20.85	(9.46)
18	(450)	1	16 1/2	(419.1)	25 1/2	(647.7)	3 1/2	(88.9)	15	(381.0)	1 1/8	4800	(21.35)	24.75	(11.23)
20	(500)	1 1/4	18	(457.2)	28	(711.2)	4 1/8	(104.8)	16 1/8	(409.6)	1 1/4	4800	(21.35)	42.45	(19.26)
24	(600)	1 1/4	20 1/4	(514.4)	32 1/4	(819.2)	4 3/4	(120.7)	18 3/8	(466.7)	1 1/4	4800	(21.35)	48.65	(22.07)
30	(750)	1 1/4	24 1/2	(622.3)	38 7/8	(987.4)	5 1/2	(139.7)	21 1/2	(546.1)	1 1/4	6000	(26.69)	69.83	(31.67)
36	(900)	1 1/2	32	(812.8)	50	(1270.0)	8 3/4	(222.3)	30	(762.0)	1 1/2	9500	(42.26)	175.00	(79.38)

Adjustment "D" (Top of cross bolt to bottom of hanger rod nut.)



# CLEVIS HANGERS



## CLEVIS HANGER FOR INSULATED PIPE LINES

**FIG. 430**

- Function:** Designed for the suspension of insulated stationary pipe lines. The elongated design permits the insulation to encompass the hanger, while maintaining a clearance between the insulation and the cross bolt. This allows the installation of the insulation to be more economical due to the fact that less cutting and fitting is required.
- Material:** Carbon steel (Type 304 or 316 Stainless Steel upon request)
- Finish:** Plain or electro-galvanized (Hot dipped galvanized with electro-galvanized hardware upon request)
- Approvals:** Complies with Federal Specifications A-A-1192A (Type 1) and Manufacturers' Standardization Society ANSI/MSS SP-58 (Type 1) which supersedes ANSI/MSS SP-69.
- Ordering:** Specify figure number, pipe size, material, and finish.

*NOTE: Use of an upper locknut ensures proper performance.*

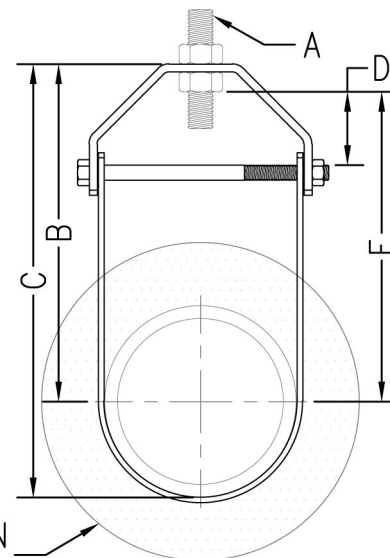

INSULATION SHOWN FOR CLARITY

Pipe Size	Rod Size A	B		C		Adjustment D		E		Cross Bolt	Max. Insulation Thickness	Wt. Each					
		lbs.	mm	lbs.	mm	in.	mm	in.	mm			lbs.	kg				
1/2	(15)	3/8	3/4	(95.25)	4 1/4	(107.95)	9/16	(14.29)	3 7/16	(87.31)	1/4	2	(50.8)	730	(3.25)	.47	(.21)
3/4	(20)	3/8	4 1/4	(107.95)	4 7/8	(123.83)	5/8	(15.88)	3 7/8	(98.43)	1/4	2	(50.8)	730	(3.25)	.48	(.22)
1	(25)	3/8	5 1/8	(130.18)	5 3/4	(146.05)	1 5/8	(41.28)	4 1 1/16	(119.06)	1/4	2	(50.8)	730	(3.25)	.55	(.25)
1 1/4	(32)	3/8	5 5/16	(134.94)	6 1/8	(155.58)	1 5/8	(41.28)	4 7/8	(123.83)	1/4	2	(50.8)	730	(3.25)	.56	(.25)
1 1/2	(40)	3/8	5 7/16	(138.11)	6 3/8	(161.93)	1 1/2	(38.10)	5	(127.00)	1/4	2	(50.8)	730	(3.25)	.61	(.28)
2	(50)	3/8	7 9/16	(192.09)	8 3/4	(222.25)	1 5/8	(41.28)	7 1/8	(180.98)	1/4	4	(101.6)	730	(3.25)	.84	(.38)
2 1/2	(65)	1/2	7 13/16	(198.44)	9 1/4	(234.95)	1 1/8	(28.58)	7 3/16	(182.56)	3/8	4	(101.6)	1350	(6.01)	1.65	(.75)
3	(80)	1/2	8 1/8	(206.38)	9 7/8	(250.83)	1 1/8	(28.58)	7 1/2	(190.50)	3/8	4	(101.6)	1350	(6.01)	1.69	(.77)
3 1/2	(90)	1/2	8 3/8	(212.73)	10 3/8	(263.53)	1 1/4	(31.75)	7 3/4	(196.85)	3/8	4	(101.6)	1350	(6.01)	1.77	(.80)
4	(100)	5/8	9 5/8	(244.48)	11 7/8	(301.63)	1 3/4	(44.45)	8 7/8	(225.43)	3/8	4	(101.6)	1430	(6.36)	2.07	(.94)
5	(125)	5/8	10 5/16	(261.94)	13 1/8	(333.38)	1 7/8	(47.63)	6 13/16	(173.04)	1/2	4	(101.6)	1430	(6.36)	2.99	(1.36)
6	(150)	3/4	10 13/16	(274.64)	14 1/8	(358.78)	1 5/8	(41.28)	9 15/16	(252.41)	1/2	4	(101.6)	1940	(8.63)	3.25	(1.47)
8	(200)	3/4	12 9/16	(319.09)	16 7/8	(428.63)	2 1/8	(53.98)	11 9/16	(293.69)	5/8	4	(101.6)	2000	(8.90)	4.60	(2.09)
10	(250)	7/8	14 1/8	(358.78)	19 1/2	(495.30)	2 5/8	(66.68)	13 3/8	(339.73)	3/4	4	(101.6)	3600	(16.01)	8.97	(4.07)
12	(300)	7/8	15 3/4	(400.05)	22 1/8	(561.98)	2 5/8	(66.68)	14 5/8	(371.48)	3/4	4	(101.6)	3800	(16.90)	11.12	(5.04)

Adjustment "D" (Top of cross bolt to bottom of hanger rod nut.)

# CLEVIS HANGERS

**FIG. 440, 440F, & 441**

## LIGHT DUTY CLEVIS HANGER

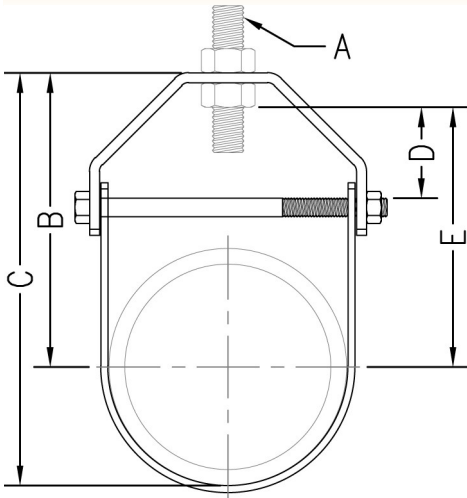

**Function:** Designed for the suspension of non-insulated stationary pipe lines in light duty applications. Fig. 440F has a layer of felt which helps to reduce sound and vibration.

**Material:** Carbon steel

**Finish:** Plain (**Fig. 440**), plain with felt lining (**Fig. 440F**), or electro-galvanized (**Fig. 441**) (Hot dipped galvanized with electro-galvanized hardware upon request)

**Approvals:** Complies with Federal Specification A-A-1192A (Type 1) and Manufacturers' Standardization Society ANSI/MSS SP-58 (Type 1) which supersedes ANSI/MSS SP-69.

**Ordering:** Specify figure number and pipe size.

**NOTE:** Use of an upper locknut ensures proper performance. If ordering Fig. 440F felt lined hangers for pipe sizes of 3 1/2" (90) or under, order the next largest size to allow for the thickness of the felt lining.

Pipe Size		Rod Size A	B		C		Adjustment D		E		Cross Bolt	Max. Rec. Load		Wt. Each	
												lbs.	kN	lbs.	kg
1/2	(15)	3/8	2 9/16	(65.09)	3	(76.20)	1 1/4	(31.75)	2 3/16	(55.56)	1/4	150	(0.67)	.17	(.08)
3/4	(20)	3/8	2 5/8	(66.68)	3 1/8	(79.38)	1 5/16	(33.34)	2 1/4	(57.15)	1/4	250	(1.11)	.22	(.10)
1	(25)	3/8	3 1/16	(77.79)	3 3/4	(95.25)	1 11/16	(42.86)	2 11/16	(68.26)	1/4	250	(1.11)	.22	(.10)
1 1/4	(32)	3/8	3 5/16	(84.14)	4 1/8	(104.78)	1 9/16	(39.69)	2 7/8	(73.03)	1/4	250	(1.11)	.29	(.13)
1 1/2	(40)	3/8	3 7/16	(87.31)	4 3/8	(111.13)	1 9/16	(39.69)	3	(76.20)	1/4	250	(1.11)	.30	(.14)
2	(50)	3/8	3 11/16	(93.66)	4 7/8	(123.83)	1 11/16	(42.86)	3 1/4	(82.55)	1/4	250	(1.11)	.34	(.15)
2 1/2	(65)	1/2	4 5/8	(117.5)	6 1/16	(154.0)	1 1/4	(31.75)	3 1/4	(82.55)	3/8	350	(1.56)	.68	(.31)
3	(80)	1/2	4 7/8	(123.83)	6 5/8	(168.28)	1 1/4	(31.75)	3 9/16	(90.49)	3/8	350	(1.56)	.72	(.33)
3 1/2	(90)	1/2	4 1/2	(114.3)	6 1/2	(165.10)	1 5/16	(33.34)	3 15/16	(100.01)	3/8	350	(1.56)	.84	(.38)
4	(100)	5/8	5 1/2	(139.7)	7 11/16	(195.3)	1 5/16	(33.34)	5	(127.00)	3/8	400	(1.78)	.97	(.44)

Adjustment "D" (Top of cross bolt to bottom of hanger rod nut.)

# CLEVIS HANGERS



## COPPER TUBING CLEVIS HANGER

**FIG. 442**

- Function:** Designed for the suspension of non-insulated stationary copper tubing.
- Material:** Carbon steel
- Finish:** Copper Color Epoxy Finish
- Approvals:** Complies with Federal Specifications A-A-1192A (Type 1) and Manufacturers' Standardization Society ANSI/MSS SP-58 (Type 1) which supersedes ANSI/MSS SP-69.
- Ordering:** Specify figure number and tube size.

*NOTE: Use of an upper locknut ensures proper performance.*

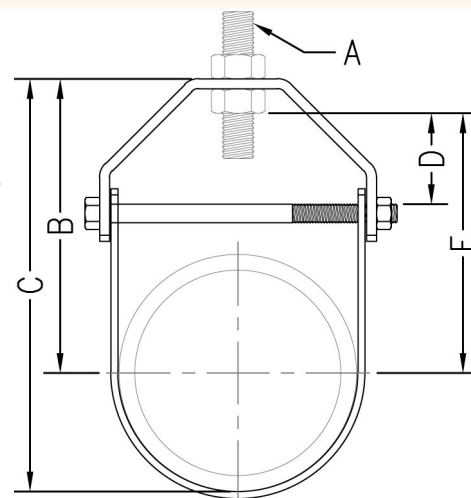

Tube Size		Rod Size A	B		C		Adjustment D		E		Cross Bolt	Max. Rec. Load		Wt. Each	
												lbs.	kN	lbs.	kg
1/2	(15)	3/8	1 7/8	(47.63)	2 3/16	(55.56)	1/2	(12.70)	1 1/8	(28.58)	1/4	150	(0.67)	.12	(.05)
3/4	(20)	3/8	1 3/4	(44.45)	2 1/8	(53.98)	1/2	(12.70)	1	(25.40)	1/4	250	(1.11)	.12	(.05)
1	(25)	3/8	1 13/16	(46.04)	2 5/16	(58.74)	1/2	(12.70)	1 1/16	(26.99)	1/4	250	(1.11)	.13	(.06)
1 1/4	(32)	3/8	2 1/8	(53.98)	2 3/4	(69.85)	3/4	(19.05)	1 5/16	(33.34)	1/4	250	(1.11)	.15	(.07)
1 1/2	(40)	3/8	2 1/2	(63.50)	3 1/4	(82.55)	15/16	(23.81)	1 3/4	(44.45)	1/4	250	(1.11)	.17	(.08)
2	(50)	3/8	2 15/16	(74.61)	4	(101.60)	1 1/16	(26.99)	2 3/16	(55.56)	1/4	250	(1.11)	.24	(.11)
2 1/2	(65)	1/2	4 7/8	(123.83)	5 3/4	(146.05)	2 1/16	(52.39)	3 3/8	(85.73)	1/4	350	(1.56)	.69	(.31)
3	(80)	1/2	4 1/2	(114.30)	6 1/8	(155.58)	2	(50.80)	3 7/16	(87.31)	1/4	350	(1.56)	.77	(.35)
3 1/2	(90)	1/2	4 3/4	(120.65)	6 1/2	(165.10)	1 13/16	(46.04)	3 11/16	(93.66)	1/4	350	(1.56)	.89	(.40)
4	(100)	1/2	5 7/8	(149.23)	7 7/8	(200.03)	2 9/16	(65.09)	4 3/4	(120.65)	5/16	400	(1.78)	.91	(.41)
5	(125)	5/8	5 7/8	(149.23)	8 3/4	(222.25)	1 5/8	(41.28)	4 3/4	(120.65)	3/8	550	(2.45)	1.90	(.86)
6	(150)	5/8	6 1/16	(153.99)	9	(228.60)	1 1/2	(38.10)	4 3/4	(120.65)	3/8	550	(2.45)	2.20	(1.00)

Adjustment "D" (Top of cross bolt to bottom of hanger rod nut.)

THREADED ACCESSORIES  
CPVC STRAPS  
BAND HANGERS  
BEAM CLAMPS  
CLEVIS HANGERS  
PIPE ROLLER SUPPORTS  
SPLIT RING HANGERS  
PIPE CLAMPS  
CENTER LOAD BEAM CLAMPS  
PIPE SHIELDS, INSULATION, & SADDLES  
PIPE GUIDES & SLIDES  
WALL BRACKETS  
PIPE SUPPORTS  
STRUCTURAL ATTACHMENTS  
SEISMIC BRACING

# CLEVIS HANGERS

## FIG. 450, 450F, 451, 451F, 453, & 454 STANDARD CLEVIS HANGER

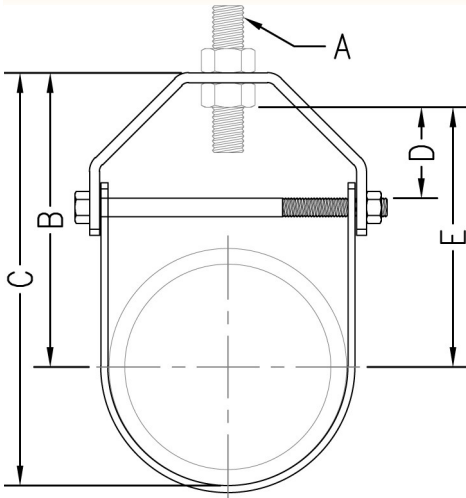

Fig. 450F, 451F, & 453 only available up to 8" (200) Pipe Size

**Function:** Designed for the suspension of non-insulated stationary pipe lines. Fig. 450F has a layer of felt which separates the pipe from the hanger to reduce vibration and sound. The PVC coating on Fig. 453 protects the pipe from the metal surface of the hanger.

**Material:** Carbon steel

**Finish:** Plain (Fig. 450), plain with felt lining (Fig. 450F), electro-galvanized (Fig. 451), electro-galvanized with felt lining (Fig. 451F), plain with PVC coating (Fig. 453), or hot dipped galvanized with electro-galvanized hardware (Fig. 454)

**Approvals:** Underwriters' Laboratories Listed in the U.S. (UL) and Canada (CUL), and Factory Mutual Approved for 2 1/2" (65) to 8" (200) only. Complies with Federal Specification A-A-1192A (Type 1) and Manufacturers' Standardization Society ANSI/MSS SP-58 (Type 1) which supersedes ANSI/MSS SP-69.

**Ordering:** Specify figure number and pipe size.

**NOTE:** Use of an upper locknut ensures proper performance. Pipe spacers provided on 30" (750mm) and larger clevises. If ordering Fig. 450F felt lined hangers for pipe sizes of 3 1/2" (90mm) or under, order the next largest size to allow for the thickness of the felt lining. When an oversized clevis is used, a pipe spacer should be placed over the clevis bolt to prevent the lower U-strap from moving inward.

Pipe Size		Rod Size A	B		C		Adjustment D		E		Cross Bolt	Max. Rec. Load		Wt. Each	
												lbs.	kN	lbs.	kg
1/2	(15)	3/8	2 1/16	(61.9)	2 7/8	(73.0)	1 1/8	(28.6)	2	(50.8)	1/4	730	(3.25)	0.24	(0.11)
3/4	(20)	3/8	2 5/8	(66.7)	3 1/8	(79.4)	1 1/4	(31.8)	2 3/16	(55.6)	1/4	730	(3.25)	0.24	(0.11)
1	(25)	3/8	3 1/16	(77.8)	3 3/4	(95.3)	1 5/8	(41.3)	2 5/8	(66.7)	1/4	730	(3.25)	0.28	(0.13)
1 1/4	(32)	3/8	3 3/8	(85.7)	4 3/16	(106.4)	1 5/8	(41.3)	2 15/16	(74.6)	1/4	730	(3.25)	0.32	(0.15)
1 1/2	(40)	3/8	3 1/2	(88.9)	4 7/16	(112.7)	1 1/2	(38.1)	3 1/16	(77.8)	1/4	730	(3.25)	0.40	(0.18)
2	(50)	3/8	3 3/4	(95.3)	5	(127.0)	1 5/8	(41.3)	3 5/16	(84.1)	1/4	730	(3.25)	0.52	(0.24)
2 1/2	(65)	1/2	4 5/8	(117.5)	6 1/16	(154.0)	2	(50.8)	4 1/16	(103.2)	3/8	1350	(6.01)	0.72	(0.33)
3	(80)	1/2	4 7/8	(123.8)	6 5/8	(168.3)	1 3/16	(46.0)	4 1/4	(108.0)	3/8	1350	(6.01)	0.78	(0.35)
3 1/2	(90)	1/2	4 1/2	(114.3)	6 1/2	(165.1)	1 1/4	(31.8)	3 7/8	(98.4)	3/8	1350	(6.01)	1.16	(0.53)
4	(100)	5/8	5 1/2	(139.7)	7 11/16	(195.3)	1 3/4	(44.5)	4 11/16	(119.1)	3/8	1430	(6.36)	1.35	(0.61)
5	(125)	5/8	6 1/8	(155.6)	9 1/8	(231.8)	1 7/8	(47.6)	5 5/16	(134.9)	1/2	1430	(6.36)	1.88	(0.85)
6	(150)	3/4	6 7/8	(174.6)	10 1/8	(257.2)	1 5/8	(41.3)	6	(152.4)	1/2	1940	(8.63)	2.76	(1.25)
8	(200)	3/4	8 3/4	(222.3)	12 7/8	(327.0)	2 1/8	(54.0)	7 7/8	(200.0)	5/8	2000	(8.90)	4.35	(1.97)
10	(250)	7/8	10 3/8	(263.5)	15 3/4	(400.1)	2 3/8	(60.3)	9 1/8	(231.8)	3/4	3600	(16.01)	8.22	(3.73)
12	(300)	7/8	11 5/8	(295.3)	18	(457.2)	2 1/2	(63.5)	10 1/2	(266.7)	3/4	3800	(16.90)	10.05	(4.56)
14	(350)	1	12 3/4	(323.9)	19 3/4	(501.7)	2 5/8	(66.7)	11 1/4	(285.8)	7/8	4200	(18.68)	12.97	(5.88)
16	(400)	1	14 1/8	(358.8)	22 7/8	(562)	2 5/8	(66.7)	13 5/8	(346.1)	1	4600	(20.46)	20.85	(9.46)
18	(450)	1	16 1/2	(419.1)	25 1/2	(647.7)	3 1/2	(88.9)	15	(381.0)	1 1/8	4800	(21.35)	24.75	(11.23)
20	(500)	1 1/4	18	(457.2)	28	(711.2)	4 1/8	(104.8)	16 1/8	(409.6)	1 1/4	4800	(21.35)	42.45	(19.26)
24	(600)	1 1/4	20 1/4	(514.4)	32 1/4	(819.2)	4 3/4	(120.7)	18 3/8	(466.7)	1 1/4	4800	(21.35)	48.65	(22.07)
30	(750)	1 1/4	24 1/2	(622.3)	38 7/8	(987.4)	5 1/2	(139.7)	21 1/2	(546.1)	1 1/4	6000	(26.69)	69.83	(31.67)
36	(900)	1 1/2	32	(812.8)	50	(1270.0)	8 3/4	(222.3)	30	(762.0)	1 1/2	9500	(42.26)	175.00	(79.38)

Adjustment "D" (Top of cross bolt to bottom of hanger rod nut.)

Unless otherwise specified, all dimensions on drawings and in charts are in inches and dimensions shown in parentheses are in millimeters.

# CLEVIS HANGERS



## PLASTIC PIPE CLEVIS HANGER

**FIG. 450V**

**Function:** Designed for the suspension of flexible plastic pipe lines. Used in conjunction with Fig. 450T.

**Material:** Carbon steel (Type 304 or 316 Stainless Steel upon request)

**Finish:** Plain or electro-galvanized (Hot dipped galvanized with electro-galvanized hardware upon request)

**Ordering:** Specify figure number, size number, material, and finish.

*NOTE: Use of an upper locknut ensures proper performance.*

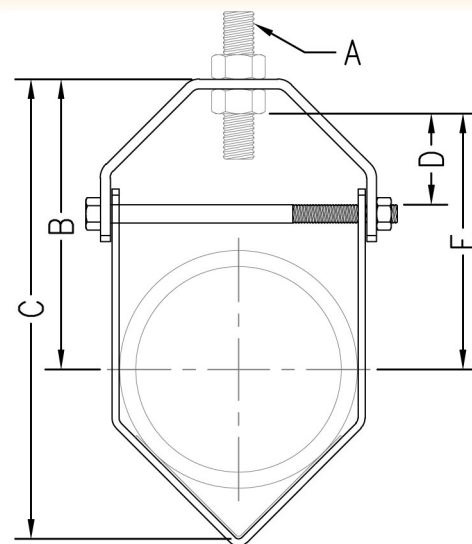

Size No.	Pipe Size		Rod Size A		B		C		Adjustment D		E		Cross Bolt	Max. Rec. Load		Wt. Each	
	in.	mm	in.	mm	in.	mm	in.	mm	in.	mm	in.	mm		lbs.	kN	lbs.	kg
1	1/2	(15)	3/8	4 3/4	(120.65)	5 1/2	(139.70)	1 5/8	(41.28)	4 5/16	(109.54)	1/4	150	(.67)	.38	(.17)	
1	3/4	(20)	3/8	4 9/16	(115.89)	5 1/2	(139.70)	1 5/8	(41.28)	4 1/8	(104.78)	1/4	150	(.67)	.38	(.17)	
1	1	(25)	3/8	6 3/8	(161.93)	5 1/2	(139.70)	1 5/8	(41.28)	3 15/16	(100.01)	1/4	150	(.67)	.38	(.17)	
1	1 1/4	(32)	3/8	4 1/8	(104.78)	5 1/2	(139.70)	1 5/8	(41.28)	3 11/16	(93.66)	1/4	150	(.67)	.38	(.17)	
1	1 1/2	(40)	3/8	4	(101.60)	5 1/2	(139.70)	1 5/8	(41.28)	3 9/16	(90.49)	1/4	150	(.67)	.38	(.17)	
1	2	(50)	3/8	3 11/16	(93.66)	5 1/2	(139.70)	1 5/8	(41.28)	3 1/4	(82.55)	1/4	150	(.67)	.38	(.17)	
2	2 1/2	(65)	5/8	6 5/8	(168.28)	8 3/4	(222.25)	1 3/4	(44.45)	5 13/16	(147.64)	3/8	150	(.67)	1.15	(.52)	
2	3	(80)	5/8	6 3/16	(157.16)	8 3/4	(222.25)	1 3/4	(44.45)	5 3/8	(136.53)	3/8	150	(.67)	1.15	(.52)	
2	3 1/2	(90)	5/8	5 13/16	(147.64)	8 3/4	(222.25)	1 3/4	(44.45)	5	(127.00)	3/8	150	(.67)	1.15	(.52)	
2	4	(100)	5/8	5 7/16	(138.11)	8 3/4	(222.25)	1 3/4	(44.45)	4 5/8	(117.48)	3/8	150	(.67)	1.15	(.52)	

Adjustment "D" (Top of cross bolt to bottom of hanger rod nut.)

## PLASTIC PIPE SUPPORT TROUGH

**FIG. 450T**

**Function:** Designed for use with Fig. 450V as a support for plastic or other flexible pipe systems. Hangers should be placed as close to the trough joints as possible.

**Material:** Carbon steel (Type 304 or 316 Stainless Steel upon request)

**Finish:** Pre-galvanized

**Ordering:** Specify figure number, size number, and material.

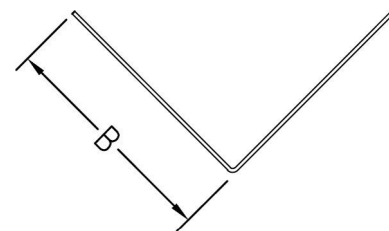

Size No.	For Pipe Sizes		B		Steel Gauge	Trough Length		Max. Rec. Load		Wt. Each	
	in.	mm	in.	mm		ft.	M	lbs.	kN	lbs.	kg
1	1/2 - 2	(15 - 50)	1 1/2	(38.1)	18 ga.	10	(3.05)	150	(.67)	.540	(.245)
2	2 1/2 - 4	(65 - 100)	3	(76.2)	18 ga.	10	(3.05)	150	(.67)	1.08	(.488)

Unless otherwise specified, all dimensions on drawings and in charts are in inches and dimensions shown in parentheses are in millimeters.

# CLEVIS HANGERS

## FIG. 455 & 456

## CLEVIS WITH SECURED INSULATION SHIELD

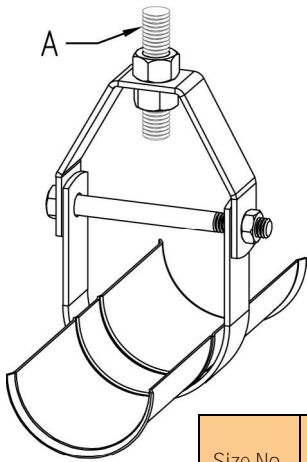

**Function:** Designed for the suspension of stationary insulated pipe lines. Fig. 455 is a combination of our Fig. 160 shield welded to a Fig. 450 or Fig. 451 clevis hanger which ensures that the shield will be installed in conjunction with the hanger. The shield is furnished with flared ends to prevent it from cutting into the insulation.

**Material:** Carbon steel (Type 304 or 316 Stainless Steel upon request)

**Finish:** Plain with pre-galvanized shield (**Fig. 455**) or electro-galvanized with pre-galvanized shield (**Fig. 456**)

**Ordering:** Specify figure number, size number, and material.

**NOTE:** To determine proper size, consult shield selection guide. Use of an upper locknut ensures proper performance.

Size No.	Rod Size A	Shield I.D.		Shield Length		Shield Gauge	Hanger Size		Wt. Each	
									lbs.	kg
1	3/8	2 3/8	(60.33)	8	(203.2)	18	2	(50)	.95	(.43)
2	1/2	2 5/8	(66.68)	8	(203.2)	18	2 1/2	(65)	1.50	(.68)
3	1/2	2 7/8	(73.03)	8	(203.2)	18	2 1/2	(65)	1.54	(.70)
4	1/2	3 1/2	(88.90)	8	(203.2)	18	3	(80)	1.62	(.73)
5	1/2	4	(101.60)	8	(203.2)	18	3 1/2	(90)	1.95	(.88)
6	5/8	4 1/2	(114.30)	8	(203.2)	18	4	(100)	2.38	(1.08)
7	5/8	5	(127.00)	8	(203.2)	18	5	(125)	2.98	(1.35)
8	5/8	5 5/8	(142.88)	8	(203.2)	18	5	(125)	3.10	(1.41)
9	3/4	6	(152.40)	8	(203.2)	18	6	(150)	3.77	(1.71)
10	3/4	6 5/8	(168.28)	8	(203.2)	18	6	(150)	3.92	(1.78)
11	3/4	7 5/8	(193.68)	12	(304.8)	18	8	(200)	6.33	(2.87)
12	3/4	8 5/8	(219.08)	12	(304.8)	18	8	(200)	6.66	(3.02)
13	7/8	9 5/8	(244.48)	12	(304.8)	18	10	(250)	10.84	(4.92)
14	7/8	10 3/4	(273.05)	12	(304.8)	18	10	(250)	11.17	(5.07)
15	7/8	10 3/4	(273.05)	12	(304.8)	18	12	(300)	13.39	(6.07)
16	7/8	12 3/4	(323.85)	12	(304.8)	18	12	(300)	13.65	(6.19)
17	1	14	(355.60)	12	(304.8)	18	14	(350)	16.93	(7.68)
18	1	15	(381.00)	12	(304.8)	18	16	(400)	25.08	(11.38)
19	1	16	(406.40)	12	(304.8)	18	16	(400)	25.20	(11.43)
20	1	17	(431.80)	12	(304.8)	18	18	(450)	29.55	(13.40)
21	1	18	(457.20)	12	(304.8)	18	18	(450)	29.83	(13.53)
22	1 1/4	19	(482.60)	12	(304.8)	18	20	(500)	47.81	(21.69)
24	1 1/4	21	(533.40)	12	(304.8)	18	24	(600)	53.73	(24.37)

Unless otherwise specified, all dimensions on drawings and in charts are in inches and dimensions shown in parentheses are in millimeters.

# CLEVIS HANGERS



## CLEVIS SERIES KLO-SHURE HANGER

## FIG. 703025 - 708362

3/8" (9.52) Insulation Thickness A														
Figure Number	Inner Diameter B	Coupling Outer Diameter C	D		E		F		G		Max. Rec. Load		Wt. Each	
											lbs.	kN	Lbs.	kg
703025*	1/4 (6.35)	1 1/8 (28.58)	-	-	-	-	-	-	-	-	-	-	0.03	(0.01)
703037*	3/8 (9.53)	1 1/4 (31.75)	-	-	-	-	-	-	-	-	-	-	0.03	(0.01)
703050*	1/2 (12.70)	1 3/8 (34.93)	-	-	-	-	-	-	-	-	-	-	0.04	(0.02)
703062*	5/8 (15.88)	1 1/2 (38.10)	-	-	-	-	-	-	-	-	-	-	0.04	(0.02)
703075*	3/4 (19.05)	1 5/8 (41.28)	-	-	-	-	-	-	-	-	-	-	0.04	(0.02)
703087	7/8 (22.23)	1 3/4 (44.45)	2 1/2 (63.50)	3 3/8 (85.73)	4 3/8 (111.13)	7 1/6 (11.11)	250	(1.11)	0.50	(0.23)				
703100*	1 (25.40)	1 7/8 (47.63)	-	-	-	-	-	-	-	-	-	-	0.05	(0.02)
703112*	1 1/8 (28.58)	2 (50.80)	2 7/8 (73.03)	3 1/2 (88.90)	4 5/8 (117.48)	5 7/8 (15.88)	250	(1.11)	0.52	(0.24)				
703137	1 3/8 (34.93)	2 1/4 (57.15)	3 3/16 (80.96)	3 3/16 (96.84)	5 (127.00)	1 5/16 (23.81)	250	(1.11)	0.54	(0.25)				
703162	1 5/8 (41.28)	2 1/2 (63.50)	3 1/2 (88.90)	4 (101.60)	5 1/2 (139.70)	1 1/16 (26.99)	250	(1.11)	0.56	(0.25)				
703212	2 1/8 (53.98)	3 (76.20)	4 3/16 (106.36)	4 3/4 (120.65)	6 1/2 (165.10)	1 5/16 (33.34)	250	(1.11)	0.65	(0.29)				
1/2" (12.7) Insulation Thickness A														
704037*	3/8 (9.53)	1 1/2 (38.10)	-	-	-	-	-	-	-	-	-	-	0.04	(0.02)
704050*	1/2 (12.70)	1 5/8 (41.28)	-	-	-	-	-	-	-	-	-	-	0.05	(0.02)
704062	5/8 (15.88)	1 3/4 (44.45)	2 1/2 (63.50)	3 3/8 (85.73)	4 3/8 (111.13)	7 1/6 (11.11)	250	(1.11)	0.50	(0.23)				
704075	3/4 (19.05)	1 7/8 (47.63)	2 5/8 (66.68)	3 7/16 (87.31)	4 1/2 (114.30)	1 1/2 (12.70)	250	(1.11)	0.50	(0.23)				
704087	7/8 (22.23)	2 (50.80)	2 7/8 (73.03)	3 1/2 (88.90)	4 5/8 (117.48)	5 7/8 (15.88)	250	(1.11)	0.52	(0.24)				
704100	1 (25.40)	2 1/8 (53.98)	3 (76.20)	3 5/8 (92.08)	4 7/8 (123.83)	7 7/8 (22.23)	250	(1.11)	0.54	(0.24)				
704112	1 1/8 (28.58)	2 1/4 (57.15)	3 3/16 (80.96)	3 3/16 (96.84)	5 (127.00)	1 5/16 (23.81)	250	(1.11)	0.55	(0.25)				
704137	1 3/8 (34.93)	2 1/2 (63.50)	3 1/2 (88.90)	4 (101.60)	5 1/2 (139.70)	1 1/16 (26.99)	250	(1.11)	0.57	(0.26)				
704162	1 5/8 (41.28)	2 3/4 (69.85)	3 3/4 (95.25)	4 3/8 (111.13)	5 7/8 (149.23)	1 1/4 (31.75)	250	(1.11)	0.62	(0.28)				
704212	2 1/8 (53.98)	3 1/4 (82.55)	4 1/2 (114.30)	5 1/8 (130.18)	6 7/8 (174.63)	1 7/16 (36.51)	250	(1.11)	0.71	(0.32)				
704262	2 5/8 (66.68)	3 3/4 (95.25)	5 (127.00)	5 5/8 (142.88)	7 5/8 (193.68)	1 11/16 (42.86)	350	(1.56)	0.98	(0.44)				
704312	3 1/8 (79.38)	4 1/4 (107.95)	5 13/16 (147.64)	6 7/16 (163.51)	8 3/4 (222.25)	2 1/8 (53.98)	350	(1.56)	1.16	(0.53)				
704362	3 5/8 (92.08)	4 3/4 (120.65)	6 5/16 (160.34)	6 7/8 (174.63)	9 3/8 (238.13)	2 5/16 (74.61)	350	(1.56)	1.21	(0.55)				
704412	4 1/8 (104.78)	5 1/4 (133.35)	6 7/8 (174.63)	7 1/2 (190.50)	10 1/8 (257.18)	2 9/16 (65.09)	350	(1.56)	1.32	(0.60)				
3/4" (19.05) Insulation Thickness A														
706025	1/4 (6.35)	1 7/8 (47.63)	2 5/8 (66.68)	3 7/16 (87.31)	4 1/2 (114.30)	1 1/2 (12.70)	250	(1.11)	0.51	(0.23)				
706037	3/8 (9.53)	2 (50.80)	2 7/8 (73.03)	3 1/2 (88.90)	4 3/8 (117.48)	5 7/8 (15.88)	250	(1.11)	0.52	(0.24)				
706050	1/2 (12.70)	2 1/8 (53.98)	3 (76.20)	3 5/8 (92.08)	4 7/8 (123.83)	7 7/8 (22.23)	250	(1.11)	0.54	(0.24)				
706062	5/8 (15.88)	2 1/4 (57.15)	3 3/16 (80.96)	3 3/16 (96.84)	5 (127.00)	1 5/16 (23.81)	250	(1.11)	0.56	(0.25)				
706075	3/4 (19.05)	2 3/8 (60.33)	3 5/16 (84.14)	3 5/16 (100.01)	5 1/4 (133.35)	1 (25.40)	250	(1.11)	0.58	(0.26)				
706087	7/8 (22.23)	2 1/2 (63.50)	3 1/2 (88.90)	4 (101.60)	5 1/2 (139.70)	1 1/16 (26.99)	250	(1.11)	0.59	(0.27)				
706112	1 1/8 (28.58)	2 3/4 (69.85)	3 3/4 (95.25)	4 3/8 (111.13)	5 7/8 (149.23)	1 1/4 (31.75)	250	(1.11)	0.64	(0.29)				
706137	1 3/8 (34.93)	3 (76.20)	4 3/16 (106.36)	4 3/4 (120.65)	6 1/2 (165.10)	1 5/16 (33.34)	250	(1.11)	0.64	(0.29)				
706162	1 5/8 (41.28)	3 1/4 (82.55)	4 1/2 (114.30)	5 1/8 (130.18)	6 7/8 (174.63)	1 7/16 (36.51)	250	(1.11)	0.69	(0.31)				
706212	2 1/8 (53.98)	3 3/4 (95.25)	5 (127.00)	5 5/8 (142.88)	7 5/8 (193.68)	1 11/16 (42.86)	350	(1.56)	0.99	(0.45)				
706262	2 5/8 (66.68)	4 1/4 (107.95)	5 13/16 (147.64)	6 7/16 (163.51)	8 3/4 (222.25)	2 1/8 (53.98)	350	(1.56)	1.18	(0.54)				
706312	3 1/8 (79.38)	4 3/4 (120.65)	6 5/16 (160.34)	6 7/8 (174.63)	9 3/8 (238.13)	2 5/16 (74.61)	350	(1.56)	1.24	(0.56)				
706362	3 5/8 (92.08)	5 1/4 (133.35)	6 7/8 (174.63)	7 1/2 (190.50)	10 1/8 (257.18)	2 9/16 (65.09)	350	(1.56)	1.35	(0.61)				
706412	4 1/8 (104.78)	5 3/4 (146.05)	7 1/4 (184.15)	7 7/8 (200.03)	10 3/4 (273.05)	2 3/4 (69.85)	350	(1.56)	1.45	(0.66)				
1" (25.4) Insulation Thickness A														
708062	5/8 (15.88)	2 3/4 (69.85)	3 3/4 (95.25)	4 3/8 (111.13)	5 7/8 (149.23)	1 1/4 (31.75)	250	(1.11)	0.66	(0.30)				
708087	7/8 (22.23)	3 (76.20)	4 3/16 (106.36)	4 3/4 (120.65)	6 1/2 (165.10)	1 5/16 (33.34)	250	(1.11)	0.68	(0.31)				
708112	1 1/8 (28.58)	3 1/4 (82.55)	4 1/2 (114.30)	5 1/8 (130.18)	6 7/8 (174.63)	1 7/16 (36.51)	250	(1.11)	0.73	(0.33)				
708137	1 3/8 (34.93)	3 1/2 (88.90)	4 3/4 (120.65)	5 3/8 (136.53)	7 1/4 (184.15)	1 9/16 (39.69)	350	(1.56)	1.05	(0.48)				
708162	1 5/8 (41.28)	3 3/4 (95.25)	5 (127.00)	5 5/8 (142.88)	7 5/8 (193.68)	1 11/16 (42.86)	350	(1.56)	1.01	(0.46)				
708212	2 1/8 (53.98)	4 1/4 (107.95)	5 13/16 (147.64)	6 7/16 (163.51)	8 3/4 (222.25)	2 1/8 (53.98)	350	(1.56)	1.16	(0.53)				
708262	2 5/8 (66.68)	4 3/4 (120.65)	6 5/16 (160.34)	6 7/8 (174.63)	9 3/8 (238.13)	2 5/16 (74.61)	350	(1.56)	1.20	(0.55)				
708312	3 1/8 (79.38)	5 1/4 (133.35)	6 7/8 (174.63)	7 1/2 (190.50)	10 1/8 (257.18)	2 9/16 (65.09)	350	(1.56)	1.38	(0.62)				
708362	3 5/8 (92.08)	5 3/4 (146.05)	7 1/4 (184.15)	7 7/8 (200.03)	10 3/4 (273.05)	2 3/4 (69.85)	350	(1.56)	1.41	(0.64)				

\*Does not include metal clevis hanger.

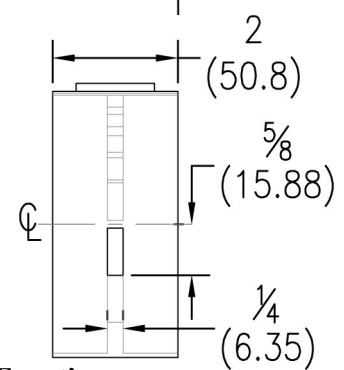
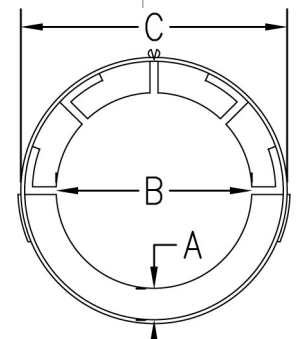
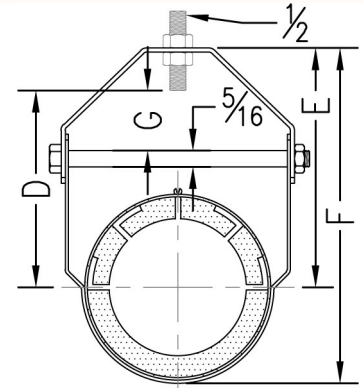

**Function:**  
 Designed for the suspension of stationary insulated OD tube or nominal pipe lines utilizing elastomeric insulation. Classified 2043 ( 25/50 ) for use in plenums and air handling systems.

**Hanger Material:**  
 Carbon steel

**Cushion Material:**  
 Washington Penn TPO in accordance with ASTM D 4000, TEO0120, A45000

**Finish:**  
 Western Gold

**Ordering:**  
 Specify figure number.

Unless otherwise specified, all dimensions on drawings and in charts are in inches and dimensions shown in parentheses are in millimeters.

THREADED ACCESSORIES  
 CPVC STRAPS  
 BAND HANGERS  
 BEAM CLAMPS  
 CLEVIS HANGERS  
 PIPE ROLLER SUPPORTS  
 SPLIT RING HANGERS  
 PIPE CLAMPS  
 CENTER LOAD BEAM CLAMPS  
 PIPE SHIELDS, INSULATION, & SADDLES  
 PIPE GUIDES & SLIDES  
 WALL BRACKETS  
 PIPE SUPPORTS  
 STRUCTURAL ATTACHMENTS  
 SEISMIC BRACING

# CLEVIS HANGERS

## FIG. 970, 970F, & 973

## J-HANGER

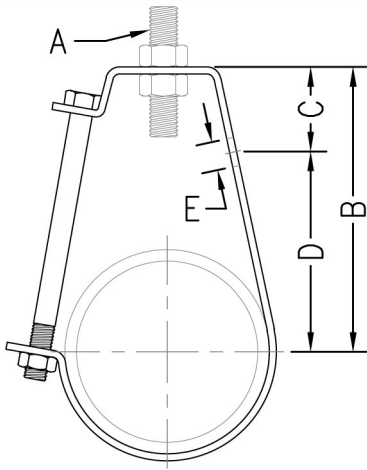

**Function:** Designed for the suspension of stationary piping systems. The “T” slot in the hanger permits the side bolt to be installed after installation and setting of pipe. The side hole permits optional wall mounting. Fig. 970F has a layer of felt which helps to reduce vibration and sound.

**Material:** Carbon steel

**Finish:** Electro-galvanized (**Fig. 970**), electro-galvanized with felt lining (**Fig. 970F**), or electro-galvanized with PVC coating (**Fig. 973**)

**Approvals:** Complies with Federal Specification A-A-1192A (Type 5) and Manufacturers’ Standardization Society ANSI/MSS SP-58 (Type 5) which supersedes ANSI/MSS SP-69.

**Ordering:** Specify figure number and pipe size.

*NOTE: If ordering Fig. 970F felt lined hangers for pipe sizes of 3 1/2" (90) or under, order the next largest size to allow for the thickness of the felt lining.*

Pipe Size	Rod Size A	B		C		D		Hole Dia. E		Max. Rec. Load		Wt. Each		
		in.	mm.	in.	mm.	in.	mm.	in.	mm.	lbs.	kN	lbs.	kg	
1/2	(15)	3/8	29/8	(66.68)	1	(25.40)	1 5/8	(41.28)	13/32	(10.32)	400	(1.78)	.20	(.09)
3/4	(20)	3/8	2 7/8	(73.03)	1	(25.40)	1 7/8	(47.63)	13/32	(10.32)	400	(1.78)	.23	(.10)
1	(25)	3/8	3 1/16	(77.79)	1	(25.40)	2 1/16	(52.39)	13/32	(10.32)	400	(1.78)	.24	(.11)
1 1/4	(32)	3/8	3 5/16	(84.14)	1 1/16	(26.99)	2 1/4	(57.15)	13/32	(10.32)	400	(1.78)	.27	(.12)
1 1/2	(40)	3/8	3 9/16	(90.49)	1 1/16	(26.99)	2 1/2	(63.50)	13/32	(10.32)	400	(1.78)	.29	(.13)
2	(50)	3/8	3 3/4	(95.25)	1 1/8	(28.58)	2 5/8	(66.68)	13/32	(10.32)	400	(1.78)	.32	(.15)
2 1/2	(65)	1/2	4 1/16	(112.71)	1 1/8	(28.58)	3 5/16	(84.14)	9/16	(14.29)	800	(3.56)	.71	(.32)
3	(80)	1/2	4 7/8	(123.83)	1 1/8	(28.58)	3 3/4	(95.25)	9/16	(14.29)	800	(3.56)	.77	(.35)
3 1/2	(90)	1/2	5 3/16	(131.76)	1 1/8	(28.58)	4 1/16	(103.19)	9/16	(14.29)	800	(3.56)	.84	(.38)
4	(100)	5/8	6 1/8	(155.58)	1 1/8	(28.58)	5	(127.00)	9/16	(14.29)	800	(3.56)	1.39	(.63)
5	(125)	5/8	6 3/4	(171.45)	1 1/8	(28.58)	5 5/8	(142.88)	9/16	(14.29)	800	(3.56)	1.66	(.75)
6	(150)	3/4	7 3/4	(196.85)	1 1/4	(31.75)	6 1/2	(165.10)	9/16	(14.29)	1000	(4.45)	2.26	(1.03)
8	(200)	3/4	9 1/4	(234.95)	1 1/4	(31.75)	8	(203.20)	9/16	(14.29)	1200	(5.34)	3.32	(1.51)



# PIPE ROLLER SUPPORTS



**FIG. 460**

## PIPE ROLLER CHAIR

- Function:** Designed for supporting pipe in applications where horizontal movement, due to expansion and contraction, will occur but vertical adjustment is not necessary. The chair can be welded directly to the steel structure or secured in place through bolt holes.
- Sizing:** Pipe roller size shown is for bare pipe. For proper sizing with insulation, refer to pipe roller selection guide, which is for use with pipe covering protection saddles.
- Material:** Cast iron pipe roller with carbon steel chair, axle, and hex nuts. (Type 304 or 316 Stainless Steel upon request)
- Finish:** Plain or electro-galvanized (Hot dipped galvanized with electro-galvanized hardware upon request)
- Approvals:** Complies with Federal Specification A-A-1192A (Type 44) and Manufacturers' Standardization Society ANSI/MSS SP-58 (Type 44) which supersedes ANSI/MSS SP-69.
- Ordering:** Specify figure number, pipe roller size, material, and finish. Order mounting bolts separately.

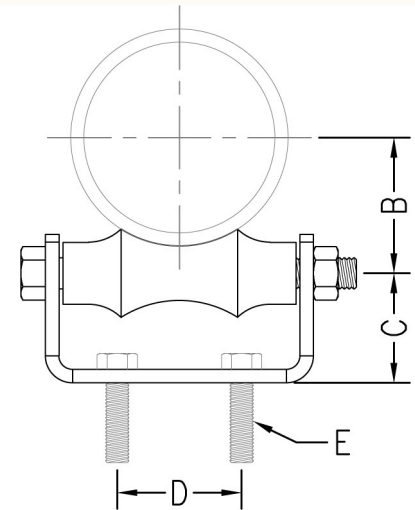

Pipe Roller Size		B		C		D		Recommended Bolt Size (Not included) E	Max. Rec. Load		Wt. Each	
									lbs.	kN	lbs.	kg
2	(50)	1 <sup>5</sup> / <sub>8</sub>	(41.28)	1 <sup>1</sup> / <sub>2</sub>	(38.10)	1 <sup>1</sup> / <sub>4</sub>	(31.75)	3/8 x 1 <sup>1</sup> / <sub>2</sub>	300	(1.33)	.90	(.41)
2 <sup>1</sup> / <sub>2</sub>	(65)	2	(50.80)	1 <sup>5</sup> / <sub>8</sub>	(41.28)	1 <sup>1</sup> / <sub>4</sub>	(31.75)	3/8 x 1 <sup>1</sup> / <sub>2</sub>	600	(2.67)	1.19	(.54)
3	(80)	2 <sup>1</sup> / <sub>4</sub>	(57.15)	1 <sup>3</sup> / <sub>4</sub>	(44.45)	2	(50.80)	3/8 x 1 <sup>1</sup> / <sub>2</sub>	600	(2.67)	1.48	(.67)
3 <sup>1</sup> / <sub>2</sub>	(90)	2 <sup>5</sup> / <sub>8</sub>	(66.68)	2	(50.80)	2	(50.80)	3/8 x 1 <sup>1</sup> / <sub>2</sub>	600	(2.67)	2.44	(1.11)
4	(100)	2 <sup>3</sup> / <sub>4</sub>	(69.85)	2 <sup>1</sup> / <sub>4</sub>	(57.15)	2	(50.80)	1/2 x 1 <sup>1</sup> / <sub>2</sub>	700	(3.11)	2.85	(1.29)
5	(125)	3 <sup>1</sup> / <sub>2</sub>	(88.90)	2 <sup>1</sup> / <sub>2</sub>	(63.50)	3	(76.20)	1/2 x 1 <sup>1</sup> / <sub>2</sub>	700	(3.11)	3.75	(1.70)
6	(150)	4	(101.60)	2 <sup>3</sup> / <sub>4</sub>	(69.85)	3 <sup>1</sup> / <sub>4</sub>	(82.55)	1/2 x 1 <sup>1</sup> / <sub>2</sub>	1000	(4.45)	5.76	(2.61)
8	(200)	5 <sup>1</sup> / <sub>8</sub>	(130.18)	3	(76.20)	3 <sup>3</sup> / <sub>8</sub>	(85.73)	5/8 x 1 <sup>1</sup> / <sub>2</sub>	1300	(5.78)	8.10	(3.67)
10	(250)	6 <sup>3</sup> / <sub>8</sub>	(161.93)	3 <sup>5</sup> / <sub>8</sub>	(92.08)	5 <sup>1</sup> / <sub>4</sub>	(133.35)	5/8 x 2	1700	(7.56)	12.28	(5.57)
12	(300)	7 <sup>1</sup> / <sub>2</sub>	(190.50)	4 <sup>1</sup> / <sub>8</sub>	(104.78)	5 <sup>1</sup> / <sub>2</sub>	(139.70)	5/8 x 2	2300	(10.23)	20.54	(9.32)
14	(350)	8 <sup>3</sup> / <sub>8</sub>	(212.73)	4 <sup>11</sup> / <sub>16</sub>	(119.06)	6 <sup>1</sup> / <sub>2</sub>	(165.10)	3/4 x 2	3100	(13.79)	25.63	(11.63)
16	(400)	9 <sup>1</sup> / <sub>2</sub>	(241.30)	5 <sup>3</sup> / <sub>8</sub>	(136.53)	8 <sup>1</sup> / <sub>4</sub>	(209.55)	3/4 x 2 <sup>1</sup> / <sub>2</sub>	3900	(17.35)	37.38	(16.96)
18	(450)	10 <sup>1</sup> / <sub>2</sub>	(266.70)	6	(152.40)	9 <sup>1</sup> / <sub>4</sub>	(234.95)	3/4 x 2 <sup>1</sup> / <sub>2</sub>	4200	(18.68)	45.26	(20.53)
20	(500)	11 <sup>5</sup> / <sub>8</sub>	(295.28)	6 <sup>3</sup> / <sub>8</sub>	(161.93)	10 <sup>3</sup> / <sub>8</sub>	(263.53)	3/4 x 2 <sup>1</sup> / <sub>2</sub>	4500	(20.02)	52.35	(23.75)
24	(600)	14	(355.60)	7 <sup>7</sup> / <sub>8</sub>	(200.03)	12 <sup>1</sup> / <sub>4</sub>	(311.15)	7/8 x 3 <sup>1</sup> / <sub>2</sub>	6000	(26.69)	88.00	(39.92)
30	(750)	17 <sup>1</sup> / <sub>4</sub>	(438.15)	9 <sup>5</sup> / <sub>8</sub>	(244.93)	15 <sup>3</sup> / <sub>8</sub>	(390.53)	7/8 x 3 <sup>1</sup> / <sub>2</sub>	7290	(32.43)	147.5	(66.9)

"B" (Center of axle to center of pipe)

THREADED ACCESSORIES  
CPVC STRAPS  
BAND HANGERS  
BEAM CLAMPS  
CLEVIS HANGERS  
PIPE ROLLER SUPPORTS  
SPLIT RING HANGERS  
PIPE CLAMPS  
CENTER LOAD BEAM CLAMPS  
PIPE SHIELDS, INSULATION, & SADDLES  
PIPE GUIDES & SLIDES  
WALL BRACKETS  
PIPE SUPPORTS  
STRUCTURAL ATTACHMENTS  
SEISMIC BRACING

# PIPE ROLLER SUPPORTS

## FIG. 470 & 475

## PIPE ROLLER HANGER

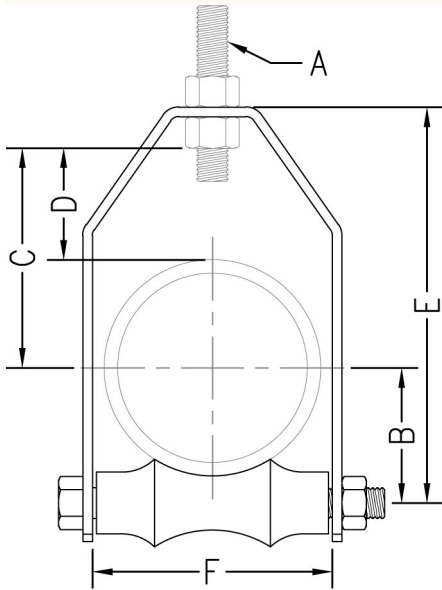

(Fig. 470)

Without adjusting swivel

- Function:** Designed for suspending pipe in applications where horizontal movement, due to expansion and contraction, will occur and vertical adjustment is necessary. The knurled insert provided with Fig. 475 allows easier vertical adjustment.
- Sizing:** Pipe roller size shown is for bare pipe. For proper sizing with insulation, refer to pipe roller selection guide, which is for use with pipe covering protection saddles.
- Material:** Cast iron pipe roller with carbon steel frame, axle, and hex nuts. (Type 304 or 316 Stainless Steel upon request)
- Finish:** Plain or electro-galvanized (Hot dipped galvanized with electro-galvanized hardware upon request)
- Approvals:** Complies with Federal Specification A-A-1192A (Type 43) and Manufacturers' Standardization Society ANSI/MSS SP-58 (Type 43) which supersedes ANSI/MSS SP-69.
- Ordering:** Specify figure number, pipe roller size, material, and finish.

*NOTE: For Fig. 470 use of an upper locknut ensures proper performance.*

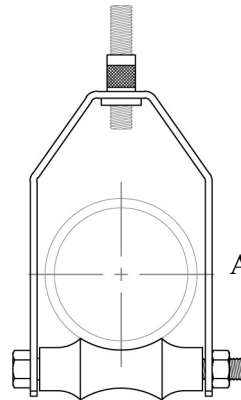

(Fig. 475)

With adjusting swivel

Available up to 8" (200)  
Pipe Roller Size

Pipe Roller Size		Rod Size A	B		C		Adjustment D		E		F		Max. Rec. Load		Wt. Each	
													lbs.	kN	lbs.	kg
2	(50)	3/8	1 5/8	(41.28)	2 5/8	(66.68)	1 1/16	(26.99)	4 3/8	(111.13)	3	(76.20)	150	(0.67)	1.05	(.48)
2 1/2	(65)	1/2	2	(50.80)	2 3/8	(60.33)	1 3/16	(30.16)	5	(127.00)	3 1/4	(82.55)	225	(1.00)	1.29	(.59)
3	(80)	1/2	2 1/4	(57.15)	3 1/2	(88.90)	1 3/4	(44.45)	6 3/8	(161.93)	3 7/8	(98.43)	310	(1.38)	1.56	(.71)
3 1/2	(90)	1/2	2 5/8	(66.68)	3 3/4	(95.25)	1 3/4	(44.45)	7	(177.80)	4 3/8	(111.13)	390	(1.73)	1.83	(.83)
4	(100)	5/8	2 3/4	(69.85)	3 15/16	(100.01)	1 11/16	(42.86)	7 1/2	(190.50)	5	(127.00)	475	(2.11)	2.81	(1.27)
5	(125)	5/8	3 1/2	(88.90)	4 5/16	(109.54)	1 9/16	(39.69)	8 5/8	(219.08)	6	(152.40)	685	(3.05)	4.42	(2.00)
6	(150)	3/4	4	(101.60)	5 3/8	(136.53)	2 1/16	(52.39)	10 1/4	(260.35)	7 1/8	(180.98)	780	(3.47)	5.98	(2.71)
8	(200)	3/4	5 1/8	(130.18)	6 1/2	(165.10)	2 3/16	(55.56)	12 3/4	(323.85)	9 1/4	(234.95)	780	(3.47)	11.42	(5.18)
10	(250)	7/8	6 3/8	(161.93)	7 3/8	(187.33)	2	(50.80)	15	(381.00)	11 1/4	(285.75)	965	(4.29)	17.36	(7.87)
12	(300)	7/8	7 1/2	(190.50)	8 3/4	(222.25)	2 3/8	(60.33)	17 3/8	(441.33)	13 1/4	(336.55)	1200	(5.34)	24.62	(11.17)
14	(350)	1	8 3/8	(212.73)	9	(228.60)	2	(50.80)	18 7/8	(479.43)	14 3/4	(374.65)	1200	(5.34)	36.00	(16.33)
16	(400)	1	9 1/2	(241.30)	9 3/4	(247.65)	1 3/4	(44.45)	20 3/4	(527.05)	16 7/8	(428.63)	1200	(5.34)	44.00	(19.96)
18	(450)	1	10 1/2	(266.70)	11 3/4	(298.45)	2 3/4	(69.85)	23 3/4	(603.25)	18 5/8	(473.08)	1400	(6.23)	54.00	(24.49)
20	(500)	1 1/4	11 5/8	(295.28)	12 1/2	(317.50)	2 1/2	(63.50)	26	(660.40)	20 7/8	(530.23)	1600	(7.12)	74.00	(33.57)
24	(600)	1 1/2	13 13/16	(350.84)	16 1/2	(419.10)	4 1/2	(114.30)	31	(787.40)	25	(635.00)	1600	(7.12)	126.00	(57.15)

"B" (Center of axle to center of pipe)

Unless otherwise specified, all dimensions on drawings and in charts are in inches and dimensions shown in parentheses are in millimeters.

# PIPE ROLLER SUPPORTS



## ADJUSTABLE PIPE ROLLER SUPPORT

## FIG. 480 & 480D

**Function:** Designed to support pipe in applications where horizontal movement, due to expansion and contraction, will occur and a vertical adjustment of up to 6" (152.4) may be required. Fig. 480D is designed for supporting and guiding pipe where longitudinal movement and vertical adjustment are required.

**Sizing:** Pipe roller size shown is for bare pipe. For proper sizing with insulation, refer to pipe roller selection guide, which is for use with pipe covering protection saddles.

**Material:** Cast iron pipe roller and sockets with carbon steel rods, axles, and hex nuts.

**Finish:** Plain or electro-galvanized (Hot dipped galvanized with electro-galvanized hardware upon request)

**Approvals:** Fig. 480 only, complies with Federal Specification A-A-1192A (Type 41) and Manufacturers' Standardization Society ANSI/MSS SP-58 (Type 41) which supersedes ANSI/MSS SP-69.

**Ordering:** Specify figure number, pipe roller size, and finish. Shipped with rods and nuts unassembled.

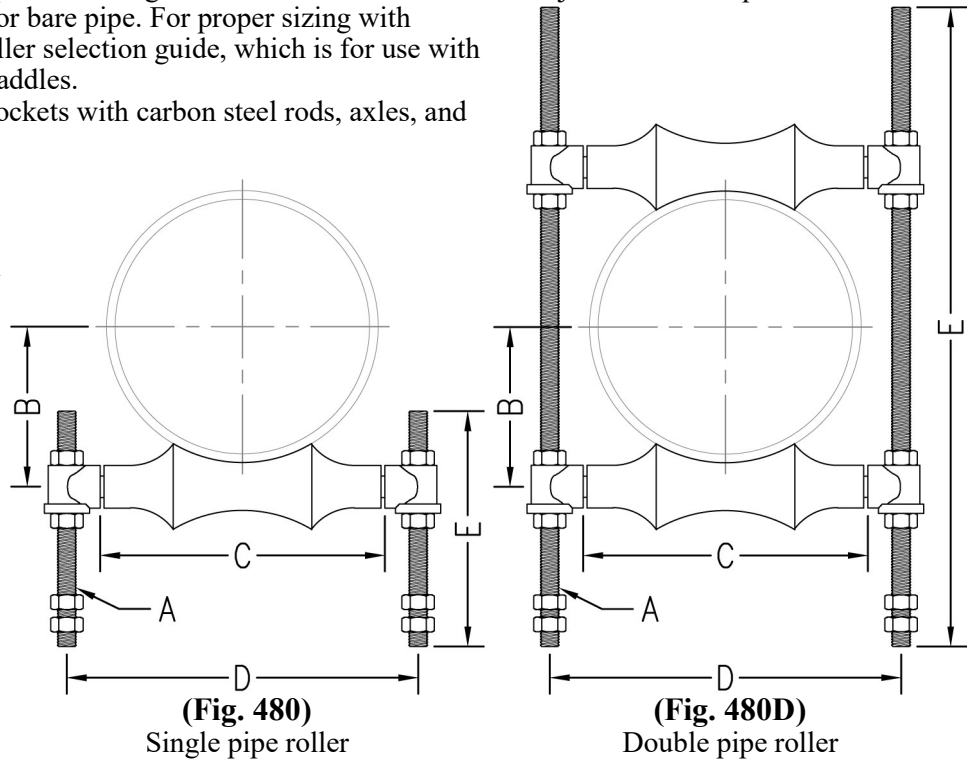

(Fig. 480)  
Single pipe roller

(Fig. 480D)  
Double pipe roller

Pipe Roller Size	Rod Size A	B		C		D		E				Max. Rec. Load		Wt. Each				
								480		480D				480		480D		
								lbs.	kN	lbs.	kg	lbs.	kg	lbs.	kg			
2	(50)	3/8	1 5/8	(41.28)	2 7/8	(73.03)	4 1/2	(114.30)	7 1/4	(184.15)	12	(304.8)	600	(2.67)	1.25	(.57)	3.26	(1.48)
2 1/2	(65)	1/2	2	(50.80)	3 1/8	(79.38)	5 1/16	(128.59)	8	(203.20)	14	(355.6)	600	(2.67)	2.25	(1.02)	4.65	(2.11)
3	(80)	1/2	2 1/4	(57.15)	3 3/4	(95.25)	5 9/16	(141.29)	8	(203.20)	14	(355.6)	700	(3.11)	2.36	(1.07)	5.01	(2.27)
3 1/2	(90)	1/2	2 5/8	(66.68)	4 1/4	(107.95)	6 1/16	(153.99)	8	(203.20)	14	(355.6)	750	(3.34)	2.60	(1.18)	5.25	(2.38)
4	(100)	5/8	2 3/4	(69.85)	4 3/4	(120.65)	6 3/4	(171.45)	9	(228.60)	18	(457.2)	750	(3.34)	3.65	(1.66)	7.57	(3.43)
5	(125)	5/8	3 1/2	(88.90)	5 3/4	(146.05)	8 3/8	(212.73)	9	(228.60)	18	(457.2)	750	(3.34)	4.59	(2.08)	8.72	(3.96)
6	(150)	3/4	4	(101.60)	6 7/8	(174.63)	9 7/8	(250.83)	10	(254.00)	24	(609.6)	1070	(4.76)	7.50	(3.40)	16.87	(7.65)
8	(200)	7/8	5 1/8	(130.18)	8 7/8	(225.43)	12	(304.80)	10	(254.00)	24	(609.6)	1350	(6.01)	11.00	(4.99)	22.77	(10.33)
10	(250)	7/8	6 3/8	(161.93)	11	(279.40)	14	(355.60)	11	(279.40)	30	(762.0)	1730	(7.70)	13.68	(6.21)	28.30	(12.84)
12	(300)	7/8	7 1/2	(190.50)	13	(330.20)	16 1/2	(419.10)	11	(279.40)	30	(762.0)	2400	(10.68)	19.30	(8.75)	38.17	(17.31)
14	(350)	1	8 3/8	(212.73)	14 3/8	(365.13)	17 3/4	(450.85)	12	(304.80)	36	(914.4)	3130	(13.92)	31.20	(14.15)	64.13	(29.09)
16	(400)	1	9 1/2	(241.30)	16 3/8	(415.93)	20 3/4	(527.05)	18	(457.20)	--	--	3970	(17.66)	42.40	(19.23)	--	--
18	(450)	1	10 1/2	(266.70)	18 3/8	(466.73)	22 3/8	(568.33)	18	(457.20)	--	--	4200	(18.68)	46.55	(21.11)	--	--
20	(500)	1 1/4	11 5/8	(295.28)	20 3/8	(517.53)	24 1/2	(622.30)	18	(457.20)	--	--	4550	(20.24)	66.00	(29.94)	--	--
24	(600)	1 1/2	14	(355.60)	24 3/8	(619.13)	28 13/16	(731.84)	24	(609.60)	--	--	6160	(27.40)	102.50	(46.49)	--	--
30	(750)	1 1/2	17 1/2	(444.50)	30 3/8	(771.53)	35	(889.00)	24	(609.60)	--	--	7290	(32.43)	186.80	(84.73)	--	--

"B" (Center of axle to center of pipe)

Unless otherwise specified, all dimensions on drawings and in charts are in inches and dimensions shown in parentheses are in millimeters.

THREADED ACCESSORIES  
CPVC STRAPS  
BAND HANGERS  
BEAM CLAMPS  
CLEVIS HANGERS  
PIPE ROLLER SUPPORTS  
SPLIT RING HANGERS  
PIPE CLAMPS  
CENTER LOAD BEAM CLAMPS  
PIPE SHIELDS, INSULATION, & SADDLES  
PIPE GUIDES & SLIDES  
WALL BRACKETS  
PIPE SUPPORTS  
STRUCTURAL ATTACHMENTS  
SEISMIC BRACING

# PIPE ROLLER SUPPORTS

**FIG. 486**

## PIPE ROLLER STAND

**Function:** Designed to support pipe in applications where horizontal movement, due to expansion and contraction, will occur.

**Sizing:** Pipe roller size shown is for bare pipe. For proper sizing with insulation, refer to pipe roller selection guide, which is for use with pipe covering protection saddles. The two holes "G" on roller sizes 2"(50) through 6"(150) are located on the outside of the stand. The two holes "G" on roller sizes 8"(200) through 42"(1050) are located on the inside of the stand, under the pipe roller.

**Material:** Cast iron pipe roller with carbon steel stand, axle, and hex nuts. (Type 304 or 316 Stainless Steel upon request)

**Finish:** Plain or electro-galvanized (Hot dipped galvanized with electro-galvanized hardware upon request)

**Approvals:** Complies with Federal Specification A-A-1192A (Type 44) and Manufacturers' Standardization Society ANSI/MSS SP-58 (Type 44) which supersedes ANSI/MSS SP-69.

**Ordering:** Specify figure number, pipe roller size, material, and finish.

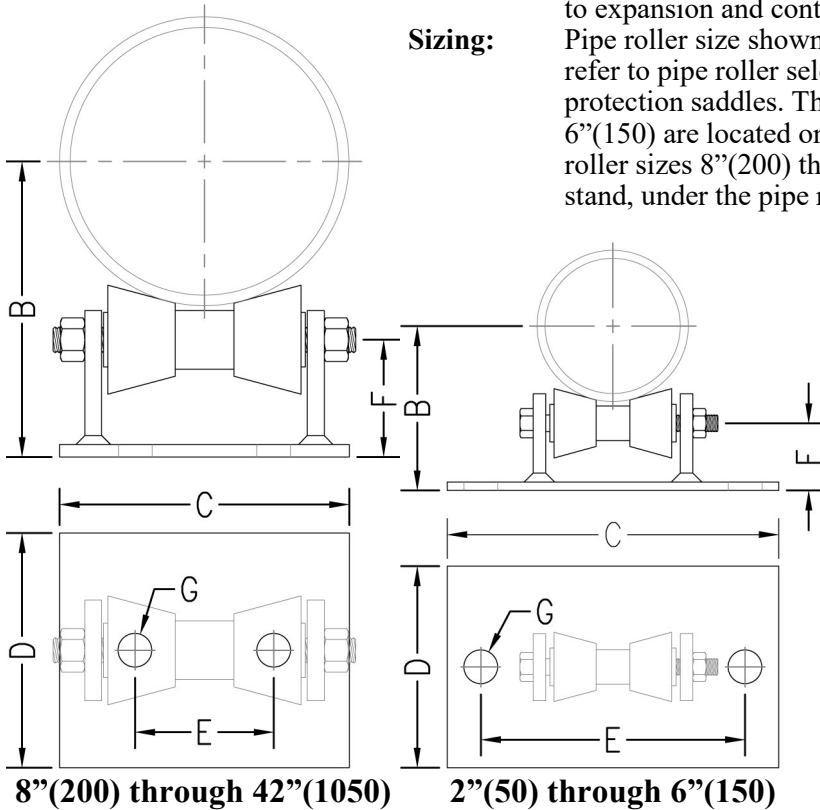

Pipe Roller Size		B		C		D		E		F		G		Max. Rec. Load		Wt. Each	
														lbs.	kN	lbs.	kg
2	(50)	3 1/2	(88.90)														
2 1/2	(65)	3 7/8	(98.43)	--	--	6	(152.4)	--	--	1 3/4	(44.45)	1	(25.4)	390	(1.73)	4.48	(2.03)
3	(80)	4 1/8	(104.78)														
3 1/2	(90)	4 3/8	(111.13)														
4	(100)	4 13/16	(122.24)														
5	(125)	5 7/16	(138.11)	--	--	6	(152.4)	--	--	2 1/16	(52.39)	1	(25.4)	950	(4.23)	6.85	(3.11)
6	(150)	6 1/16	(153.99)														
8	(200)	8 11/16	(220.66)	8 5/8	(219.08)	7	(177.8)	4 1/8	(104.78)	3 7/16	(87.31)	1	(25.4)	2100	(9.34)	14.09	(6.39)
10	(250)	9 13/16	(249.24)														
12	(300)	11 3/8	(288.93)	10 7/8	(276.23)	8	(203.2)	5 13/16	(147.64)	3 7/8	(98.43)	1	(25.4)	3075	(13.68)	22.09	(10.02)
14	(350)	12	(304.80)														
16	(400)	13 5/8	(346.08)														
18	(450)	14 5/8	(371.48)	12 1/2	(317.50)	9	(228.6)	6 7/8	(174.63)	4 1/4	(107.95)	1	(25.4)	4980	(22.15)	32.00	(14.51)
20	(500)	15 5/8	(396.88)														
24	(600)	17 3/4	(450.85)	13 1/2	(342.90)	9	(228.6)	7 5/8	(193.68)	4 3/8	(111.13)	1	(25.4)	6100	(27.13)	41.43	(18.79)
30	(750)	21 7/8	(555.63)	17	(431.80)	12	(304.8)	10	(254.00)	5 1/8	(130.18)	1	(25.4)	7500	(33.36)	80.00	(36.29)
36	(900)	25 3/4	(654.05)														
42	(1050)	28 7/8	(733.43)	20	(508.00)	12	(304.8)	12	(304.80)	5 3/4	(146.05)	1	(25.4)	12000	(53.38)	125.0	(56.70)

Unless otherwise specified, all dimensions on drawings and in charts are in inches and dimensions shown in parentheses are in millimeters.

# PIPE ROLLER SUPPORTS



## ADJUSTABLE PIPE ROLLER STAND WITH BASE

**FIG. 487**

- Function:** Designed to support pipe in applications where horizontal movement, due to expansion and contraction, will occur and vertical adjustment is required.
- Sizing:** Pipe roller size shown is for bare pipe. For proper sizing with insulation, refer to pipe roller selection guide, which is for use with pipe covering protection saddles.
- Material:** Cast iron pipe roller with carbon steel stand, axle, and adjusting screws with locknuts. (Type 304 or 316 Stainless Steel upon request)
- Finish:** Plain or electro-galvanized (Hot dipped galvanized with electro-galvanized hardware upon request)
- Approvals:** Complies with Federal Specification A-A-1192A (Type 46) and Manufacturers' Standardization Society ANSI/MSS SP-58 (Type 46) which supersedes ANSI/MSS SP-69.
- Ordering:** Specify figure number, pipe roller size, material, and finish.
- NOTE:** Refer to Fig. 486 for measurements of roller stand.

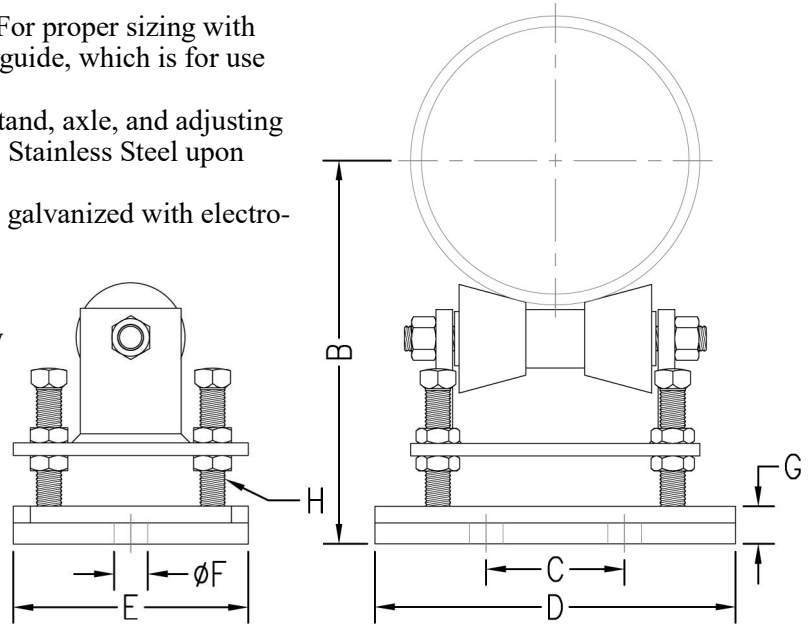

Pipe Roller Size	B		C	D	E	Hole Size F	G	Bolt Size H	Max. Rec. Load		Wt. Each								
	Min.	Max.							lbs.	kN	lbs.	kg							
2 (50)	5 1/8	(130.18)	5 3/8	(136.53)															
2 1/2 (65)	5 3/8	(136.53)	5 5/8	(142.88)															
3 (80)	5 3/4	(146.05)	6	(152.40)	3 7/8	(98.43)	7	(177.80)	5 1/2	(139.70)	1	(25.4)	1	(25.4)	5/8	390	(1.73)	12.03	(5.46)
3 1/2 (90)	6	(152.40)	6 1/4	(158.75)															
4 (100)	6 1/2	(165.10)	7	(177.80)															
5 (125)	7	(177.80)	7 1/2	(190.50)	5 1/8	(130.18)	8 3/8	(212.73)	6	(152.4)	1	(25.4)	1	(25.4)	5/8	950	(4.23)	15.24	(6.91)
6 (150)	7 5/8	(193.68)	8 1/8	(206.38)															
8 (200)	10 3/8	(263.53)	11 5/8	(295.28)	7 3/8	(187.33)	10 3/4	(273.05)	7	(177.8)	1	(25.4)	1 1/8	(28.58)	3/4	2100	(9.34)	30.59	(13.88)
10 (250)	11 1/2	(292.10)	12 3/4	(323.85)															
12 (300)	13	(330.20)	14 1/4	(361.95)	9 1/2	(241.30)	13 1/2	(342.90)	8 3/8	(212.73)	1	(25.4)	1 3/8	(34.93)	7/8	3075	(13.68)	44.96	(20.39)
14 (350)	13 5/8	(346.08)	14 7/8	(377.83)															
16 (400)	15 1/4	(387.35)	16 5/8	(422.28)															
18 (450)	16 3/8	(415.93)	17 3/4	(450.85)	11 1/8	(282.58)	14 1/2	(368.30)	9	(228.6)	1	(25.4)	1 3/8	(34.93)	1	4980	(22.15)	64.10	(29.08)
20 (500)	17 3/8	(441.33)	18 3/4	(476.25)															
24 (600)	19 5/8	(498.48)	21	(533.40)	12 1/4	(311.15)	16 1/4	(412.75)	9 1/4	(234.95)	1	(25.4)	1 3/8	(34.93)	1	6100	(27.13)	76.68	(34.78)
30 (750)	24	(609.60)	26 3/4	(679.45)	15 3/4	(400.05)	19 1/4	(488.95)	12	(304.8)	1	(25.4)	1 5/8	(41.28)	1 1/4	7500	(33.36)	142.25	(64.52)
36 (900)	23 3/16	(588.96)	29 3/16	(741.36)															
42 (1050)	29 1/4	(742.95)	32 1/4	(819.15)	16	(406.40)	22	(558.80)	12	(304.8)	1	(25.4)	1 5/8	(41.28)	1 1/2	12000	(53.38)	156.23	(70.86)

Unless otherwise specified, all dimensions on drawings and in charts are in inches and dimensions shown in parentheses are in millimeters.

THREADED ACCESSORIES  
CPVC STRAPS  
BAND HANGERS  
BEAM CLAMPS  
CLEVIS HANGERS  
PIPE ROLLER SUPPORTS  
SPLIT RING HANGERS  
PIPE CLAMPS  
CENTER LOAD BEAM CLAMPS  
PIPE SHIELDS, INSULATION, & SADDLES  
PIPE GUIDES & SLIDES  
WALL BRACKETS  
PIPE SUPPORTS  
STRUCTURAL ATTACHMENTS  
SEISMIC BRACING

# PIPE ROLLER SUPPORTS

**FIG. 488**

## FABRICATED ROLLER FOR LARGE PIPING

**Function:** Designed to support pipe in applications where horizontal movement, due to expansion and contraction, will occur.

**Sizing:** Pipe roller size shown for bare pipe.

**Material:** Carbon steel

**Finish:** Plain or electro-galvanized

**Ordering:** Specify figure number and finish.

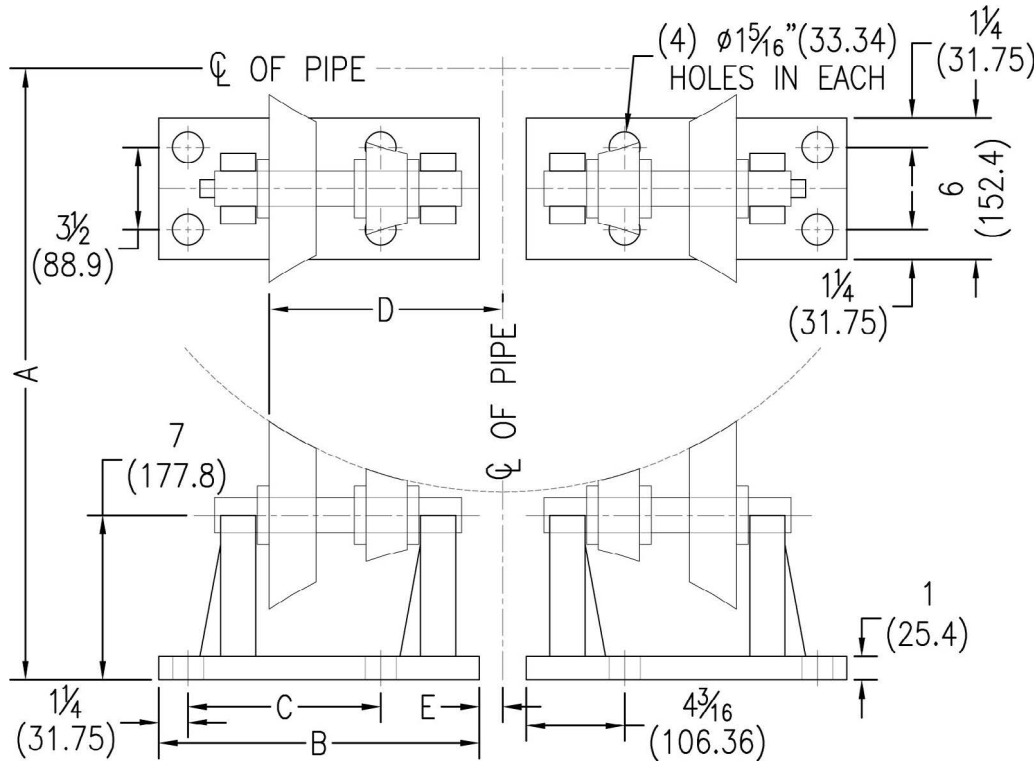

Pipe Size		A		B		C		D		E		Max. Rec. Load		Wt. Each	
		in	mm	in	mm	in	mm	in	mm	in	mm	lbs.	kN	lbs.	kg
30	(750)	23 <sup>1</sup> / <sub>4</sub>	(590.55)	13 <sup>5</sup> / <sub>8</sub>	(346.08)	8 <sup>3</sup> / <sub>16</sub>	(207.96)	8 <sup>13</sup> / <sub>16</sub>	(223.84)	0	(0)	60000	(266.89)	142	(64.41)
36	(900)	26	(660.40)	13 <sup>5</sup> / <sub>8</sub>	(346.08)	8 <sup>3</sup> / <sub>16</sub>	(207.96)	9 <sup>15</sup> / <sub>16</sub>	(252.41)	1	(25.40)	60000	(266.89)	142	(64.41)
42	(1050)	28 <sup>15</sup> / <sub>16</sub>	(735.01)	13 <sup>5</sup> / <sub>8</sub>	(346.08)	8 <sup>3</sup> / <sub>16</sub>	(207.96)	10 <sup>15</sup> / <sub>16</sub>	(277.81)	2	(50.80)	60000	(266.89)	142	(64.41)
46	(1150)	30 <sup>7</sup> / <sub>8</sub>	(784.23)	13 <sup>5</sup> / <sub>8</sub>	(346.08)	8 <sup>3</sup> / <sub>16</sub>	(207.96)	11 <sup>7</sup> / <sub>16</sub>	(290.51)	2 <sup>7</sup> / <sub>16</sub>	(61.91)	60000	(266.89)	142	(64.41)
46	(1150)	31 <sup>1</sup> / <sub>8</sub>	(790.58)	16 <sup>1</sup> / <sub>4</sub>	(412.75)	10 <sup>13</sup> / <sub>16</sub>	(274.64)	12 <sup>7</sup> / <sub>8</sub>	(327.03)	1 <sup>1</sup> / <sub>4</sub>	(31.75)	60000	(266.89)	186	(84.37)
48	(1200)	32	(812.80)	16 <sup>1</sup> / <sub>4</sub>	(412.75)	10 <sup>13</sup> / <sub>16</sub>	(274.64)	13 <sup>1</sup> / <sub>4</sub>	(336.55)	1 <sup>11</sup> / <sub>16</sub>	(42.86)	60000	(266.89)	186	(84.37)
54	(1350)	34 <sup>7</sup> / <sub>8</sub>	(885.83)	16 <sup>1</sup> / <sub>4</sub>	(412.75)	10 <sup>13</sup> / <sub>16</sub>	(274.64)	14 <sup>5</sup> / <sub>16</sub>	(363.54)	2 <sup>3</sup> / <sub>4</sub>	(69.85)	60000	(266.89)	186	(84.37)
60	(1500)	37 <sup>3</sup> / <sub>4</sub>	(958.85)	16 <sup>1</sup> / <sub>4</sub>	(412.75)	10 <sup>13</sup> / <sub>16</sub>	(274.64)	15 <sup>7</sup> / <sub>8</sub>	(403.23)	3 <sup>15</sup> / <sub>16</sub>	(100.01)	60000	(266.89)	186	(84.37)
66	(1650)	40 <sup>9</sup> / <sub>16</sub>	(1030.29)	16 <sup>1</sup> / <sub>4</sub>	(412.75)	10 <sup>13</sup> / <sub>16</sub>	(274.64)	16 <sup>1</sup> / <sub>2</sub>	(419.10)	5	(127.00)	60000	(266.89)	186	(84.37)
72	(1800)	43 <sup>3</sup> / <sub>8</sub>	(1101.73)	16 <sup>1</sup> / <sub>4</sub>	(412.75)	10 <sup>13</sup> / <sub>16</sub>	(274.64)	17 <sup>5</sup> / <sub>8</sub>	(447.68)	6 <sup>1</sup> / <sub>16</sub>	(153.99)	60000	(266.89)	186	(84.37)

Unless otherwise specified, all dimensions on drawings and in charts are in inches and dimensions shown in parentheses are in millimeters.

# PIPE ROLLER SUPPORTS



## PIPE ROLLER WITH SOCKETS

**FIG. 490**

- Function:** Designed to support pipe in applications where horizontal movement, due to expansion and contraction, will occur.
- Sizing:** Pipe roller size shown is for bare pipe. For proper sizing with insulation, refer to pipe roller selection guide, which is for use with pipe covering protection saddles.
- Material:** Cast iron pipe roller and sockets with carbon steel axle.
- Finish:** Plain or electro-galvanized (Hot dipped galvanized with electro-galvanized hardware upon request)
- Approvals:** Complies with Federal Specification A-A-1192A (Type 41) and Manufacturers' Standardization Society ANSI/MSS SP-58 (Type 41) which supersedes ANSI/MSS SP-69.
- Ordering:** Specify figure number, pipe roller size, and finish.

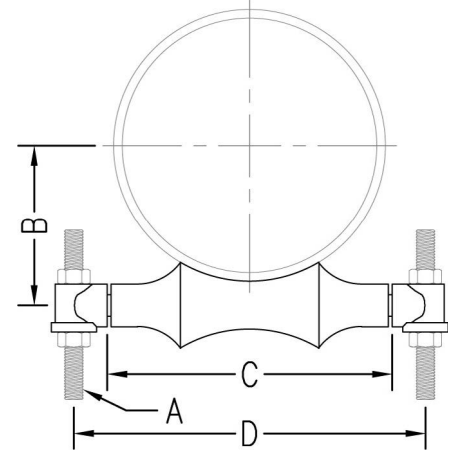

Pipe Roller Size		Rod Size A	B		C		D		Max. Rec. Load		Wt. Each	
									lbs.	kN	lbs.	kg
2	(50)	3/8	1 5/8	(41.28)	2 7/8	(73.03)	4 1/2	(114.30)	600	(2.67)	.57	(.26)
2 1/2	(65)	1/2	2	(50.80)	3 1/8	(79.38)	5 1/16	(128.59)	660	(2.94)	.98	(.44)
3	(80)	1/2	2 1/4	(57.15)	3 3/4	(95.25)	5 9/16	(141.29)	700	(3.11)	1.10	(.50)
3 1/2	(90)	1/2	2 5/8	(66.68)	4 1/4	(107.95)	6 1/16	(153.99)	750	(3.34)	1.36	(.62)
4	(100)	5/8	2 3/4	(69.85)	4 3/4	(120.65)	6 3/4	(171.45)	750	(3.34)	1.62	(.73)
5	(125)	5/8	3 1/2	(88.90)	5 3/4	(146.05)	8 3/8	(212.73)	750	(3.34)	2.60	(1.18)
6	(150)	3/4	4	(101.60)	6 7/8	(174.63)	9 7/8	(250.83)	1070	(4.76)	4.42	(2.00)
8	(200)	7/8	5 1/8	(130.18)	8 7/8	(225.43)	12	(304.80)	1350	(6.01)	7.20	(3.27)
10	(250)	7/8	6 3/8	(161.93)	11	(279.40)	14	(355.60)	1730	(7.70)	9.50	(4.31)
12	(300)	7/8	7 1/2	(190.50)	13	(330.20)	16 1/2	(419.10)	2400	(10.68)	16.00	(7.26)
14	(350)	1	8 3/8	(212.73)	14 3/8	(365.13)	17 3/4	(450.85)	3130	(13.92)	24.20	(10.98)
16	(400)	1	9 1/2	(241.30)	16 3/8	(415.93)	20 3/4	(527.05)	3970	(17.66)	31.80	(14.42)
18	(450)	1	10 1/2	(266.70)	18 3/8	(466.73)	22 3/8	(568.33)	4200	(18.68)	35.15	(15.94)
20	(500)	1 1/4	11 5/8	(295.28)	20 3/8	(517.53)	24 1/2	(622.30)	4550	(20.24)	47.00	(21.32)
24	(600)	1 1/2	14	(355.60)	24 3/8	(619.13)	28 13/16	(731.84)	6160	(27.40)	76.20	(34.56)
30	(750)	1 1/2	17 1/2	(444.50)	30 3/8	(771.53)	35	(889.00)	7290	(32.43)	130.00	(58.97)

"B" (Center of axle to center of pipe)

THREADED ACCESSORIES  
 CPVC STRAPS  
 BAND HANGERS  
 BEAM CLAMPS  
 CLEVIS HANGERS  
 PIPE ROLLER SUPPORTS  
 SPLIT RING HANGERS  
 PIPE CLAMPS  
 CENTER LOAD BEAM CLAMPS  
 PIPE SHIELDS, INSULATION, & SADDLES  
 PIPE GUIDES & SLIDES  
 WALL BRACKETS  
 PIPE SUPPORTS  
 STRUCTURAL ATTACHMENTS  
 SEISMIC BRACING

# PIPE ROLLER SUPPORTS

**FIG. 485**

## SHORT PIPE ROLLER

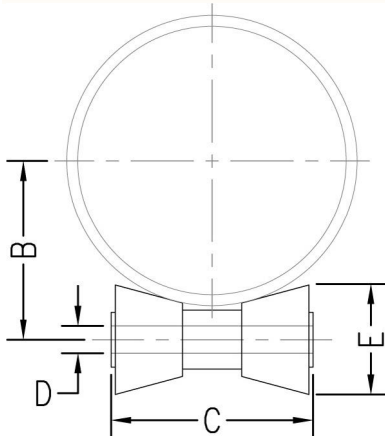

**Function:** Designed for supporting pipe in applications where horizontal movement, due to expansion and contraction, will occur.

**Material:** Cast iron (Type 304 or 316 Stainless Steel upon request)

**Finish:** Plain or electro-galvanized (Hot dipped galvanized upon request)

**Ordering:** Specify figure number, pipe roller size, material, and finish.

Pipe Roller Size		B		C		Hole Size D		E		Max. Rec. Load		Wt. Each	
										lbs.	kN	lbs.	kg
2	(50)	1 <sup>3</sup> / <sub>16</sub>	(46.04)	2 <sup>3</sup> / <sub>4</sub>	(69.85)	9/ <sub>16</sub>	(14.29)	1 <sup>5</sup> / <sub>16</sub>	(49.21)	390	(1.73)	0.81	(0.37)
2 <sup>1</sup> / <sub>2</sub>	(65)	2 <sup>1</sup> / <sub>8</sub>	(53.98)	2 <sup>3</sup> / <sub>4</sub>	(69.85)	9/ <sub>16</sub>	(14.29)	1 <sup>5</sup> / <sub>16</sub>	(49.21)	390	(1.73)	0.81	(0.37)
3	(80)	2 <sup>7</sup> / <sub>16</sub>	(61.91)	2 <sup>3</sup> / <sub>4</sub>	(69.85)	9/ <sub>16</sub>	(14.29)	1 <sup>5</sup> / <sub>16</sub>	(49.21)	390	(1.73)	0.81	(0.37)
3 <sup>1</sup> / <sub>2</sub>	(90)	2 <sup>11</sup> / <sub>16</sub>	(68.26)	2 <sup>3</sup> / <sub>4</sub>	(69.85)	9/ <sub>16</sub>	(14.29)	1 <sup>5</sup> / <sub>16</sub>	(49.21)	390	(1.73)	0.81	(0.37)
4	(100)	3	(76.20)	3 <sup>3</sup> / <sub>4</sub>	(95.25)	9/ <sub>16</sub>	(14.29)	2 <sup>1</sup> / <sub>4</sub>	(57.15)	950	(4.23)	0.94	(0.42)
5	(125)	3 <sup>9</sup> / <sub>16</sub>	(90.49)	3 <sup>3</sup> / <sub>4</sub>	(95.25)	9/ <sub>16</sub>	(14.29)	2 <sup>1</sup> / <sub>4</sub>	(57.15)	950	(4.23)	0.94	(0.42)
6	(150)	4 <sup>1</sup> / <sub>8</sub>	(104.78)	3 <sup>3</sup> / <sub>4</sub>	(95.25)	9/ <sub>16</sub>	(14.29)	2 <sup>1</sup> / <sub>4</sub>	(57.15)	950	(4.23)	0.94	(0.42)
8	(200)	5 <sup>1</sup> / <sub>4</sub>	(133.35)	6	(152.40)	1 <sup>3</sup> / <sub>16</sub>	(20.64)	3 <sup>3</sup> / <sub>16</sub>	(80.96)	2100	(9.34)	3.19	(1.45)
10	(250)	6 <sup>3</sup> / <sub>8</sub>	(161.93)	6	(152.40)	1 <sup>3</sup> / <sub>16</sub>	(20.64)	3 <sup>3</sup> / <sub>16</sub>	(80.96)	2100	(9.34)	3.19	(1.45)
12	(300)	7 <sup>1</sup> / <sub>2</sub>	(190.50)	8	(203.20)	1	(25.40)	4	(101.60)	3075	(13.68)	6.64	(3.01)
14	(350)	8 <sup>3</sup> / <sub>16</sub>	(207.96)	8	(203.20)	1	(25.40)	4	(101.60)	3075	(13.68)	6.64	(3.01)
16	(400)	9 <sup>5</sup> / <sub>16</sub>	(236.54)	9	(228.60)	1 <sup>1</sup> / <sub>4</sub>	(31.75)	4 <sup>1</sup> / <sub>2</sub>	(114.30)	4980	(22.15)	8.31	(3.77)
18	(450)	10 <sup>3</sup> / <sub>8</sub>	(263.53)	9	(228.60)	1 <sup>1</sup> / <sub>4</sub>	(31.75)	4 <sup>1</sup> / <sub>2</sub>	(114.30)	4980	(22.15)	8.31	(3.77)
20	(500)	11 <sup>7</sup> / <sub>16</sub>	(290.51)	9	(228.60)	1 <sup>1</sup> / <sub>4</sub>	(31.75)	4 <sup>1</sup> / <sub>2</sub>	(114.30)	4980	(22.15)	8.31	(3.77)
24	(600)	13 <sup>7</sup> / <sub>16</sub>	(341.31)	10	(254.00)	1 <sup>1</sup> / <sub>2</sub>	(38.10)	4 <sup>3</sup> / <sub>8</sub>	(111.13)	6100	(27.13)	8.40	(3.81)
30	(750)	16 <sup>9</sup> / <sub>16</sub>	(420.69)	12 <sup>1</sup> / <sub>4</sub>	(311.15)	1 <sup>7</sup> / <sub>8</sub>	(47.63)	5 <sup>3</sup> / <sub>16</sub>	(131.76)	7500	(33.36)	14.40	(6.53)
36	(900)	19 <sup>11</sup> / <sub>16</sub>	(500.06)	14	(355.60)	2 <sup>1</sup> / <sub>8</sub>	(53.98)	6	(152.40)	12000	(53.38)	16.80	(7.62)
42	(1050)	22 <sup>3</sup> / <sub>4</sub>	(577.85)	14	(355.60)	2 <sup>1</sup> / <sub>8</sub>	(53.98)	6	(152.40)	12000	(53.38)	16.80	(7.62)



# PIPE ROLLER SUPPORTS



## LONG PIPE ROLLER

**FIG. 495**

**Function:** Designed for supporting pipe in applications where horizontal movement, due to expansion and contraction, will occur.

**Material:** Cast iron (Type 304 or 316 Stainless Steel upon request)

**Finish:** Plain or electro-galvanized (Hot dipped galvanized upon request)

**Ordering:** Specify figure number, pipe roller size, material, and finish.

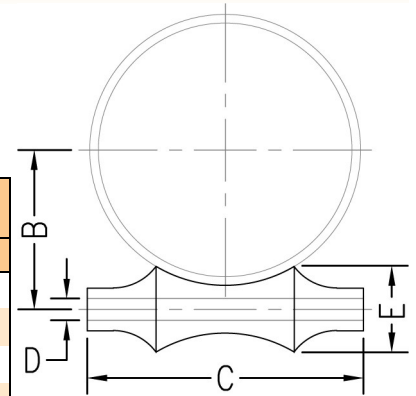

Pipe Roller Size		B		C		Hole Size D		E		Max. Rec. Load		Wt. Each	
										lbs.	kN	lbs.	kg
2	(50)	1 <sup>5</sup> / <sub>8</sub>	(41.28)	2 <sup>7</sup> / <sub>8</sub>	(73.03)	7 <sup>1</sup> / <sub>16</sub>	(11.11)	1 <sup>3</sup> / <sub>16</sub>	(30.16)	600	(2.67)	0.22	(0.10)
2 <sup>1</sup> / <sub>2</sub>	(65)	2	(50.80)	3 <sup>1</sup> / <sub>8</sub>	(79.38)	9 <sup>1</sup> / <sub>16</sub>	(14.29)	1 <sup>7</sup> / <sub>16</sub>	(36.51)	700	(3.11)	0.33	(0.15)
3	(80)	2 <sup>1</sup> / <sub>4</sub>	(57.15)	3 <sup>3</sup> / <sub>4</sub>	(95.25)	9 <sup>1</sup> / <sub>16</sub>	(14.29)	1 <sup>1</sup> / <sub>2</sub>	(38.10)	700	(3.11)	0.43	(0.20)
3 <sup>1</sup> / <sub>2</sub>	(90)	2 <sup>5</sup> / <sub>8</sub>	(66.68)	4 <sup>1</sup> / <sub>4</sub>	(107.95)	9 <sup>1</sup> / <sub>16</sub>	(14.29)	1 <sup>5</sup> / <sub>8</sub>	(41.28)	750	(3.34)	0.53	(0.24)
4	(100)	2 <sup>3</sup> / <sub>4</sub>	(69.85)	4 <sup>3</sup> / <sub>4</sub>	(120.65)	9 <sup>1</sup> / <sub>16</sub>	(14.29)	2	(50.80)	750	(3.34)	0.56	(0.26)
5	(125)	3 <sup>1</sup> / <sub>2</sub>	(88.90)	5 <sup>3</sup> / <sub>4</sub>	(146.05)	1 <sup>1</sup> / <sub>16</sub>	(17.46)	2 <sup>1</sup> / <sub>8</sub>	(53.98)	750	(3.34)	0.94	(0.43)
6	(150)	4	(101.60)	6 <sup>7</sup> / <sub>8</sub>	(174.63)	1 <sup>3</sup> / <sub>16</sub>	(20.64)	2 <sup>7</sup> / <sub>16</sub>	(61.91)	1100	(4.89)	1.59	(0.72)
8	(200)	5 <sup>1</sup> / <sub>8</sub>	(130.18)	8 <sup>7</sup> / <sub>8</sub>	(225.43)	1 <sup>5</sup> / <sub>16</sub>	(23.81)	2 <sup>7</sup> / <sub>8</sub>	(73.03)	1350	(6.01)	2.64	(1.20)
10	(250)	6 <sup>3</sup> / <sub>8</sub>	(161.93)	11	(279.40)	1 <sup>5</sup> / <sub>16</sub>	(23.81)	3 <sup>1</sup> / <sub>2</sub>	(88.90)	1750	(7.78)	4.50	(2.04)
12	(300)	7 <sup>1</sup> / <sub>2</sub>	(190.50)	13	(330.20)	1 <sup>5</sup> / <sub>16</sub>	(23.81)	4 <sup>1</sup> / <sub>4</sub>	(107.95)	2400	(10.68)	7.55	(3.42)
14	(350)	8 <sup>3</sup> / <sub>8</sub>	(212.73)	14 <sup>3</sup> / <sub>8</sub>	(365.13)	1 <sup>1</sup> / <sub>4</sub>	(31.75)	4 <sup>5</sup> / <sub>8</sub>	(117.48)	3100	(13.79)	13.00	(5.90)
16	(400)	9 <sup>1</sup> / <sub>2</sub>	(241.30)	16 <sup>3</sup> / <sub>8</sub>	(415.93)	1 <sup>3</sup> / <sub>8</sub>	(34.93)	4 <sup>7</sup> / <sub>8</sub>	(123.83)	4000	(17.79)	17.44	(7.91)
18	(450)	10 <sup>1</sup> / <sub>2</sub>	(266.70)	18 <sup>3</sup> / <sub>8</sub>	(466.73)	1 <sup>3</sup> / <sub>8</sub>	(34.93)	5 <sup>5</sup> / <sub>16</sub>	(134.94)	4200	(18.68)	21.60	(9.80)
20	(500)	11 <sup>5</sup> / <sub>8</sub>	(295.28)	20 <sup>3</sup> / <sub>8</sub>	(517.53)	1 <sup>3</sup> / <sub>8</sub>	(34.93)	6 <sup>1</sup> / <sub>16</sub>	(153.99)	4550	(20.24)	27.13	(12.30)
24	(600)	14	(355.60)	14 <sup>3</sup> / <sub>8</sub>	(365.13)	1 <sup>5</sup> / <sub>8</sub>	(41.28)	7 <sup>1</sup> / <sub>16</sub>	(179.39)	6100	(27.13)	43.29	(19.63)
30	(750)	17 <sup>1</sup> / <sub>2</sub>	(444.50)	30 <sup>3</sup> / <sub>8</sub>	(771.53)	1 <sup>7</sup> / <sub>8</sub>	(47.63)	9 <sup>1</sup> / <sub>16</sub>	(230.19)	7300	(32.47)	82.00	(37.19)

## ROLLER SOCKET

**FIG. 496**

**Function:** Designed for use with Fig. 495.

**Material:** Cast iron

**Finish:** Plain or electro-galvanized (Hot dipped galvanized upon request)

**Ordering:** Specify figure number, socket number, and finish.

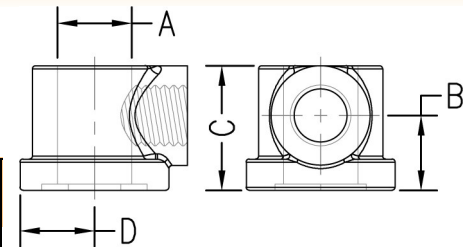

Socket Number	Rod Size A	Use with Pipe Roller Size	Axle Size	B		C		D		Wt. Each	
										lbs.	kg
1	3 <sup>8</sup> / <sub>8</sub>	2	3 <sup>8</sup> / <sub>8</sub>	5 <sup>8</sup> / <sub>8</sub>	(15.88)	1	(25.40)	1 <sup>1</sup> / <sub>16</sub>	(17.46)	.12	(.05)
2	1 <sup>2</sup> / <sub>2</sub>	2 <sup>1</sup> / <sub>2</sub> to 3 <sup>1</sup> / <sub>2</sub>	1 <sup>2</sup> / <sub>2</sub>	3 <sup>4</sup> / <sub>4</sub>	(19.05)	1 <sup>1</sup> / <sub>4</sub>	(31.75)	1 <sup>1</sup> / <sub>16</sub>	(17.46)	.27	(.12)
2A	5 <sup>8</sup> / <sub>8</sub>	4	1 <sup>2</sup> / <sub>2</sub>	7 <sup>8</sup> / <sub>8</sub>	(22.23)	1 <sup>1</sup> / <sub>4</sub>	(31.75)	1 <sup>3</sup> / <sub>16</sub>	(20.64)	.25	(.11)
3	5 <sup>8</sup> / <sub>8</sub>	5	5 <sup>8</sup> / <sub>8</sub>	1	(25.40)	1 <sup>9</sup> / <sub>16</sub>	(39.69)	1	(25.40)	.53	(.24)
4	3 <sup>4</sup> / <sub>4</sub>	6	3 <sup>4</sup> / <sub>4</sub>	1 <sup>1</sup> / <sub>4</sub>	(31.75)	1 <sup>13</sup> / <sub>16</sub>	(46.04)	1 <sup>1</sup> / <sub>8</sub>	(28.58)	.92	(.42)
5	7 <sup>8</sup> / <sub>8</sub>	8 to 12	7 <sup>8</sup> / <sub>8</sub>	1 <sup>1</sup> / <sub>4</sub>	(31.75)	2 <sup>1</sup> / <sub>8</sub>	(53.98)	1 <sup>1</sup> / <sub>8</sub>	(28.58)	1.44	(.65)
7	1	14	1 <sup>1</sup> / <sub>8</sub>	1 <sup>3</sup> / <sub>4</sub>	(44.45)	2 <sup>3</sup> / <sub>8</sub>	(60.33)	1 <sup>3</sup> / <sub>8</sub>	(34.93)	2.03	(.92)
8	1	16 to 18	1 <sup>1</sup> / <sub>4</sub>	1 <sup>13</sup> / <sub>16</sub>	(46.04)	3	(76.20)	1 <sup>5</sup> / <sub>8</sub>	(41.28)	2.60	(1.18)
8A	1 <sup>1</sup> / <sub>4</sub>	20	1 <sup>1</sup> / <sub>4</sub>	1 <sup>13</sup> / <sub>16</sub>	(46.04)	3	(76.20)	1 <sup>5</sup> / <sub>8</sub>	(41.28)	2.56	(1.16)
9B	1 <sup>1</sup> / <sub>2</sub>	24	1 <sup>1</sup> / <sub>2</sub>	2 <sup>3</sup> / <sub>16</sub>	(55.56)	3 <sup>3</sup> / <sub>8</sub>	(85.73)	2 <sup>1</sup> / <sub>16</sub>	(52.39)	4.96	(2.25)
10	1 <sup>1</sup> / <sub>2</sub>	30	1 <sup>3</sup> / <sub>4</sub>	2 <sup>9</sup> / <sub>16</sub>	(65.09)	4	(101.60)	2 <sup>5</sup> / <sub>16</sub>	(58.74)	6.94	(3.15)

Unless otherwise specified, all dimensions on drawings and in charts are in inches and dimensions shown in parentheses are in millimeters.

# PIPE ROLLER SELECTION GUIDE

**For use with pipe covering protection saddle, figures 651-658 .**

Pipe Thickness		Insulation Thickness		Pipe Roller Size			Pipe Thickness		Insulation Thickness		Pipe Roller Size		
				Use with Fig. No.							Use with Fig. No.		
				460, 480, 483 & 490	470 & 475	486 & 487					460, 480, 483 & 490	470 & 475	486 & 487
1/2	(15)	1	(25.4)	2	2 1/2	2 - 3 1/2	6	(150)	1	(25.4)	8	8	4 - 6
		1 1/2	(38.1)	3	3 1/2	2 - 3 1/2			1 1/2	(38.1)	8	10	8 - 10
3/4	(20)	2	(50.8)	4	5	2 - 3 1/2	8	(200)	2	(50.8)	10	10	8 - 10
		1	(25.4)	2	2 1/2	2 - 3 1/2			2 1/2	(63.5)	10	12	8 - 10
1	(25)	1 1/2	(38.1)	3	3 1/2	2 - 3 1/2	10	(250)	3	(76.2)	12	12	8 - 10
		2	(50.8)	4	5	2 - 3 1/2			4	(101.6)	14	16	12 - 14
1 1/4	(32)	2 1/2	(63.5)	5	6	4 - 6	12	(300)	1	(25.4)	10	12	8 - 10
		1	(25.4)	2 1/2	3	2 - 3 1/2			1 1/2	(38.1)	10	12	8 - 10
1 1/2	(40)	1 1/2	(38.1)	3 1/2	5	2 - 3 1/2	14	(350)	2	(50.8)	12	14	8 - 10
		2	(50.8)	5	6	4 - 6			2 1/2	(63.5)	14	16	12 - 14
2	(50)	2 1/2	(63.5)	6	8	4 - 6	16	(400)	3	(76.2)	16	18	16 - 20
		3	(76.2)	8	8	4 - 6			4	(101.6)	18	20	16 - 20
2 1/2	(65)	4	(101.6)	8	10	8 - 10	18	(450)	1 1/2	(38.1)	16	18	12 - 14
		1	(25.4)	3 1/2	5	2 - 3 1/2			2	(50.8)	16	18	16 - 20
3	(80)	1 1/2	(38.1)	5	6	4 - 6	20	(500)	2 1/2	(63.5)	18	20	16 - 20
		2	(50.8)	6	8	4 - 6			3	(76.2)	20	20	16 - 20
3 1/2	(90)	2 1/2	(63.5)	8	8	4 - 6	24	(600)	4	(101.6)	20	--	16 - 20
		3	(76.2)	8	10	8 - 10			1 1/2	(38.1)	20	--	24
4	(100)	4	(101.6)	10	12	8 - 10	30	(750)	2	(50.8)	24	--	24
		1	(25.4)	5	6	4 - 6			2 1/2	(63.5)	24	--	24
5	(125)	1 1/2	(38.1)	8	8	4 - 6	36	(900)	3	(76.2)	24	--	24
		2	(50.8)	8	10	8 - 10			4	(101.6)	24	--	24
		2 1/2	(63.5)	10	10	8 - 10			1 1/2	(38.1)	30	--	30
		3	(76.2)	10	12	8 - 10			2	(50.8)	30	--	30
		4	(101.6)	12	14	8 - 10			3	(76.2)	30	--	30
									4	(101.6)	30	--	30
											--	--	36-42
											--	--	36-42
											--	--	36-42
											--	--	36-42
											--	--	36-42
											--	--	36-42
											--	--	36-42
											--	--	36-42

Unless otherwise specified, all dimensions on drawings and in charts are in inches and dimensions shown in parentheses are in millimeters.

# SPLIT RING HANGERS



THREADED ACCESSORIES  
 CPVC STRAPS  
 BAND HANGERS  
 BEAM CLAMPS  
 CLEVIS HANGERS  
 PIPE ROLLER SUPPORTS  
 SPLIT RING HANGERS  
 PIPE CLAMPS  
 CENTER LOAD BEAM CLAMPS  
 PIPE SHIELDS, INSULATION, & SADDLES  
 PIPE GUIDES & SLIDES  
 WALL BRACKETS  
 PIPE SUPPORTS  
 STRUCTURAL ATTACHMENTS  
 SEISMIC BRACING

## HINGED EXTENSION SPLIT CLAMP

**FIG. 508R**

- Function:** Designed for non-insulated stationary pipe lines in either a horizontal or vertical position. The hinged design allows for a quick installation.
- Material:** Malleable iron
- Finish:** Plain or electro-galvanized
- Approvals:** Complies with Federal Specification A-A-1192A (Type 12) and Manufacturers' Standardization Society ANSI/MSS SP-58 (Type 12) which supersedes ANSI/MSS SP-69.
- Ordering:** Specify figure number, pipe size, and finish.

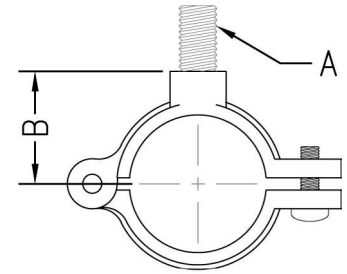

Pipe Size		Bolt Thread A	B		Max. Rec. Load		Wt. Each	
					lbs.	kN	lbs.	kg
3/8	(10)	3/8	13/16	(20.64)	180	(0.80)	.13	(.06)
1/2	(15)	3/8	7/8	(22.23)	180	(0.80)	.14	(.06)
3/4	(20)	3/8	1	(25.40)	180	(0.80)	.16	(.07)
1	(25)	3/8	1 1/8	(28.58)	180	(0.80)	.18	(.08)
1 1/4	(32)	3/8	1 5/16	(33.34)	180	(0.80)	.22	(.10)
1 1/2	(40)	3/8	1 7/16	(36.51)	180	(0.80)	.38	(.17)
2	(50)	3/8	1 11/16	(42.86)	180	(0.80)	.44	(.20)
2 1/2	(65)	1/2	2 1/8	(53.98)	300	(1.33)	.45	(.20)
3	(80)	1/2	2 7/16	(61.91)	300	(1.33)	.55	(.25)
4	(100)	1/2	3	(76.20)	300	(1.33)	.95	(.43)

## EXTENSION SPLIT CLAMP

**FIG. 510R**

- Function:** Designed for non-insulated stationary pipe lines in either a horizontal or vertical position.
- Material:** Malleable iron (Type 304 or 316 Stainless Steel upon request)
- Finish:** Plain or electro-galvanized
- Approvals:** Complies with Federal Specification A-A-1192A (Type 12) and Manufacturers' Standardization Society ANSI/MSS SP-58 (Type 12) which supersedes ANSI/MSS SP-69.
- Ordering:** Specify figure number, pipe size, material, and finish.

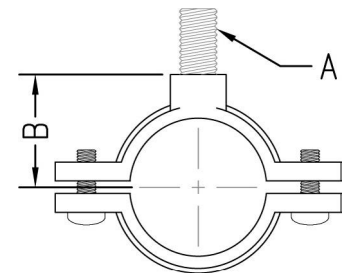

Pipe Size		Bolt Thread A	B		Max. Rec. Load		Wt. Each	
					lbs.	kN	lbs.	kg
3/8	(10)	3/8	13/16	(20.64)	180	(0.80)	.13	(.06)
1/2	(15)	3/8	7/8	(22.23)	180	(0.80)	.14	(.06)
3/4	(20)	3/8	1	(25.40)	180	(0.80)	.16	(.07)
1	(25)	3/8	1 1/8	(28.58)	180	(0.80)	.18	(.08)
1 1/4	(32)	3/8	1 5/16	(33.34)	180	(0.80)	.22	(.10)
1 1/2	(40)	3/8	1 7/16	(36.51)	180	(0.80)	.38	(.17)
2	(50)	3/8	1 11/16	(42.86)	180	(0.80)	.44	(.20)
2 1/2	(65)	1/2	2 1/8	(53.98)	300	(1.33)	.45	(.20)
3	(80)	1/2	2 7/16	(61.91)	300	(1.33)	.55	(.25)
4	(100)	1/2	3 11/32	(84.93)	300	(1.33)	.70	(.32)

Unless otherwise specified, all dimensions on drawings and in charts are in inches and dimensions shown in parentheses are in millimeters.

# SPLIT RING HANGERS

**FIG. 512**

## COPPER TUBING EXTENSION SPLIT CLAMP

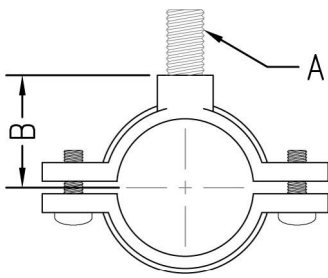

**Function:** Designed for non-insulated stationary tubing lines in either a horizontal or vertical position.

**Material:** Malleable iron

**Finish:** Copper color epoxy finish

**Approvals:** Complies with Federal Specification A-A-1192A (Type 12) and Manufacturers' Standardization Society ANSI/MSS SP-58 (Type 12) which supersedes ANSI/MSS SP-69.

**Ordering:** Specify figure number and pipe size.

Tube Size	Bolt Thread A	B		Max. Rec. Load		Wt. Each		
				lbs.	kN	lbs.	kg	
3/8	(10)	3/8	9/16	(14.29)	180	(0.80)	.07	(.03)
1/2	(15)	3/8	11/16	(17.46)	180	(0.80)	.09	(.04)
3/4	(20)	3/8	7/8	(22.23)	180	(0.80)	.09	(.04)
1	(25)	3/8	1	(25.40)	180	(0.80)	.10	(.05)
1 1/4	(32)	3/8	1 1/8	(28.58)	180	(0.80)	.12	(.05)
1 1/2	(40)	3/8	1 5/16	(33.34)	180	(0.80)	.13	(.06)
2	(50)	3/8	1 1/2	(38.10)	180	(0.80)	.18	(.08)
2 1/2	(65)	1/2	1 7/8	(47.63)	300	(1.33)	.65	(.29)
3	(80)	1/2	2 1/8	(53.98)	300	(1.33)	1.00	(.45)
4	(100)	1/2	2 3/4	(69.85)	300	(1.33)	1.40	(.64)

**FIG. 512H**

## HINGED COPPER TUBING EXTENSION SPLIT CLAMP

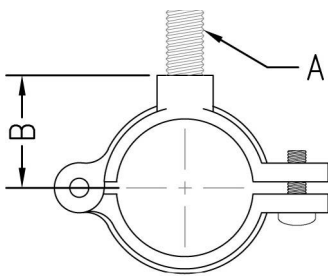

**Function:** Designed for non-insulated stationary tubing lines in either a horizontal or vertical position. The hinged design of Fig. 512H allows for a quicker installation.

**Material:** Malleable iron

**Finish:** Copper color epoxy finish

**Approvals:** Complies with Federal Specification A-A-1192A (Type 12) and Manufacturers' Standardization Society ANSI/MSS SP-58 (Type 12) which supersedes ANSI/MSS SP-69.

**Ordering:** Specify figure number and pipe size.

Tube Size	Bolt Thread A	B		Max. Rec. Load		Wt. Each		
				lbs.	kN	lbs.	kg	
3/8	(10)	3/8	9/16	(14.29)	180	(0.80)	.08	(.04)
1/2	(15)	3/8	11/16	(17.46)	180	(0.80)	.09	(.04)
3/4	(20)	3/8	7/8	(22.23)	180	(0.80)	.12	(.05)
1	(25)	3/8	1	(25.40)	180	(0.80)	.11	(.05)
1 1/4	(32)	3/8	1 1/8	(28.58)	180	(0.80)	.15	(.07)
1 1/2	(40)	3/8	1 5/16	(33.34)	180	(0.80)	.20	(.09)
2	(50)	3/8	1 1/2	(38.10)	180	(0.80)	.25	(.11)
2 1/2	(65)	1/2	1 7/8	(47.63)	300	(1.33)	.45	(.20)
3	(80)	1/2	2 1/8	(53.98)	300	(1.33)	.55	(.25)
4	(100)	1/2	2 3/4	(69.85)	300	(1.33)	.90	(.41)

Unless otherwise specified, all dimensions on drawings and in charts are in inches and dimensions shown in parentheses are in millimeters.

# PIPE CLAMPS



## STANDARD PIPE CLAMP

## FIG. 520 & 521

**Function:** Designed to be used in the suspension of non-insulated pipe lines. Normally used in conjunction with Fig. 35 weldless eye nut, Fig. 50 eye rod or Fig. 55 welded eye rod to allow flexibility at the rod attachment.

**Material:** Carbon steel (Type 304 or 316 Stainless Steel upon request)

**Finish:** Plain (**Fig. 520**) or electro-galvanized (**Fig. 521**) (Hot dipped galvanized with electro-galvanized hardware upon request)

**Approvals:** Complies with Federal Specification A-A-1192A (Type 4) and Manufacturers' Standardization Society ANSI/MSS SP-58 (Type 4) which supersedes ANSI/MSS SP-69.

**Ordering:** Specify figure number, pipe size, material, and finish.

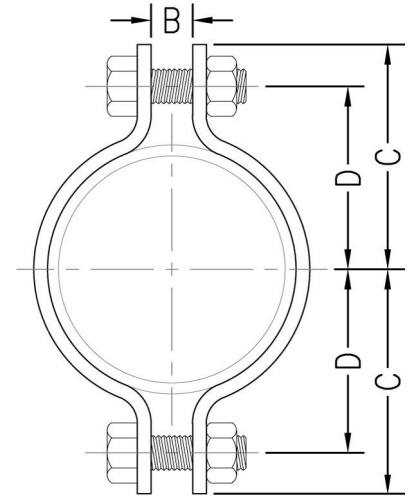

Pipe Size		B		C		D		Bolt Size	Max. Rec. Load				Wt. Each	
									650°F (343°C)		750°F (399°C)			
									lbs.	kN	lbs.	kN	lbs.	kg
1/2	(15)	3/8	(9.53)	1 9/16	(39.69)	1 1/16	(26.99)	3/8	500	(2.22)	445	(1.98)	.31	(.14)
3/4	(20)	3/8	(9.53)	1 3/4	(44.45)	1 1/4	(31.75)	3/8	500	(2.22)	445	(1.98)	.35	(.16)
1	(25)	3/8	(9.53)	1 7/8	(47.63)	1 3/8	(34.93)	3/8	500	(2.22)	445	(1.98)	.39	(.18)
1 1/4	(32)	3/8	(9.53)	2 1/8	(53.98)	1 5/8	(41.28)	3/8	500	(2.22)	445	(1.98)	.40	(.18)
1 1/2	(40)	3/8	(9.53)	2 1/4	(57.15)	1 3/4	(44.45)	3/8	800	(3.56)	715	(3.18)	.45	(.20)
2	(50)	1/2	(12.70)	2 9/16	(65.09)	2 1/16	(52.39)	1/2	1040	(4.63)	930	(4.14)	.90	(.41)
2 1/2	(65)	5/8	(15.88)	2 13/16	(71.44)	2 5/16	(58.74)	1/2	1040	(4.63)	930	(4.14)	1.10	(.50)
3	(80)	5/8	(15.88)	3 5/16	(84.14)	2 13/16	(71.44)	1/2	1040	(4.63)	930	(4.14)	1.20	(.54)
3 1/2	(90)	5/8	(15.88)	3 1/2	(88.90)	3 3/16	(80.96)	1/2	1040	(4.63)	930	(4.14)	1.25	(.57)
4	(100)	3/4	(19.05)	4 1/8	(104.78)	3 3/8	(85.73)	5/8	1040	(4.63)	930	(4.14)	1.85	(.84)
5	(125)	3/4	(19.05)	4 3/4	(120.65)	4	(101.60)	5/8	1040	(4.63)	930	(4.14)	2.05	(.93)
6	(150)	7/8	(22.23)	5 7/8	(149.23)	4 7/8	(123.83)	3/4	1615	(7.18)	1440	(6.41)	5.06	(2.30)
8	(200)	1	(25.40)	7	(177.80)	6	(152.40)	3/4	1615	(7.18)	1440	(6.41)	6.08	(2.76)
10	(250)	1	(25.40)	8 13/16	(223.84)	7 9/16	(192.09)	7/8	2490	(11.08)	2220	(9.88)	12.81	(5.81)
12	(300)	1	(25.40)	9 7/8	(250.83)	8 7/8	(225.43)	7/8	2490	(11.08)	2220	(9.88)	13.08	(5.93)
14	(350)	1 1/8	(28.58)	11 5/16	(287.34)	9 15/16	(252.41)	7/8	2490	(11.08)	2220	(9.88)	16.70	(7.57)
16	(400)	1 1/8	(28.58)	12 5/8	(320.68)	10 7/8	(276.23)	7/8	2490	(11.08)	2220	(9.88)	23.19	(10.52)
18	(450)	1 1/4	(31.75)	13 3/8	(339.73)	11 5/8	(295.28)	1	3060	(13.61)	2730	(12.14)	33.12	(15.02)
20	(500)	1 3/8	(34.93)	14 5/16	(363.54)	12 9/16	(319.09)	1 1/8	3060	(13.61)	2730	(12.14)	38.66	(17.54)
24	(600)	1 5/8	(41.28)	17 1/4	(438.15)	15 1/2	(393.70)	1 1/4	3060	(13.61)	2730	(12.14)	52.27	(23.71)
30	(750)	2	(50.80)	20 7/8	(530.23)	18 5/8	(473.08)	1 1/2	4000	(17.79)	3520	(15.66)	105.13	(47.69)

Unless otherwise specified, all dimensions on drawings and in charts are in inches and dimensions shown in parentheses are in millimeters.

THREADED ACCESSORIES  
CPVC STRAPS  
BAND HANGERS  
BEAM CLAMPS  
CLEVIS HANGERS  
PIPE ROLLER SUPPORTS  
SPLIT RING HANGERS  
PIPE CLAMPS  
CENTER LOAD BEAM CLAMPS  
PIPE SHIELDS, INSULATION, & SADDLES  
PIPE GUIDES & SLIDES  
WALL BRACKETS  
PIPE SUPPORTS  
STRUCTURAL ATTACHMENTS  
SEISMIC BRACING

# PIPE CLAMPS

**FIG. 522**

## HEAVY DUTY PIPE CLAMP

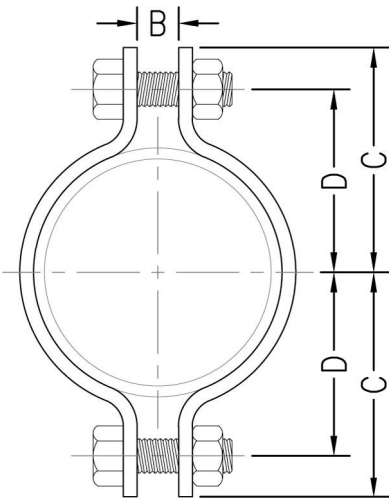

**Function:** Designed to be used in the suspension of non-insulated pipe lines where heavier loads are to be suspended. Normally used in conjunction with Fig. 35 weldless eye nut or Fig. 55 welded eye rod to allow flexibility at the rod attachment.

**Material:** Carbon steel (Type 304 or 316 Stainless Steel upon request)  
**Finish:** Plain or electro-galvanized (Hot dipped galvanized with electro-galvanized hardware upon request)

**Approvals:** Complies with Federal Specification A-A-1192A (Type 4) and Manufacturers' Standardization Society ANSI/MSS SP-58 (Type 4) which supersedes ANSI/MSS SP-69.

**Ordering:** Specify figure number, pipe size, material, and finish.

Pipe Size	B		C		D		Bolt Size	Max. Rec. Load				Wt. Each		
								650°F (343°C)		750°F (399°C)				
								lbs.	kN	lbs.	kN	lbs.	kg	
3	(80)	1	(25.40)	4 <sup>1</sup> / <sub>8</sub>	(104.78)	3 <sup>1</sup> / <sub>8</sub>	(79.38)	3/4	3370	(14.99)	3005	(13.37)	4.96	(2.25)
3 <sup>1</sup> / <sub>2</sub>	(90)	1	(25.40)	4 <sup>3</sup> / <sub>8</sub>	(111.13)	3 <sup>3</sup> / <sub>8</sub>	(85.73)	3/4	3370	(14.99)	3005	(13.37)	5.36	(2.43)
4	(100)	1	(25.40)	4 <sup>15</sup> / <sub>16</sub>	(125.41)	3 <sup>15</sup> / <sub>16</sub>	(100.01)	7/8	3515	(15.64)	3135	(13.95)	5.74	(2.60)
5	(125)	1	(25.40)	5 <sup>9</sup> / <sub>16</sub>	(141.29)	4 <sup>9</sup> / <sub>16</sub>	(115.89)	7/8	3515	(15.64)	3135	(13.95)	7.13	(3.23)
6	(150)	1 <sup>1</sup> / <sub>8</sub>	(28.58)	6 <sup>1</sup> / <sub>16</sub>	(169.86)	5 <sup>3</sup> / <sub>16</sub>	(131.76)	1	4865	(21.64)	4340	(19.31)	13.48	(6.11)
8	(200)	1 <sup>1</sup> / <sub>8</sub>	(28.58)	7 <sup>5</sup> / <sub>8</sub>	(193.68)	6 <sup>1</sup> / <sub>8</sub>	(155.58)	1	4865	(21.64)	4340	(19.31)	16.42	(7.45)
10	(250)	1 <sup>1</sup> / <sub>4</sub>	(31.75)	9 <sup>3</sup> / <sub>16</sub>	(233.36)	7 <sup>1</sup> / <sub>16</sub>	(195.26)	1 <sup>1</sup> / <sub>4</sub>	6010	(26.73)	5360	(23.84)	15.86	(7.19)
12	(300)	1 <sup>5</sup> / <sub>8</sub>	(41.28)	11	(279.40)	9 <sup>1</sup> / <sub>8</sub>	(231.78)	1 <sup>1</sup> / <sub>2</sub>	8675	(38.59)	7740	(34.43)	44.50	(20.18)
14	(350)	1 <sup>5</sup> / <sub>8</sub>	(41.28)	11 <sup>7</sup> / <sub>8</sub>	(301.63)	9 <sup>3</sup> / <sub>4</sub>	(247.65)	1 <sup>1</sup> / <sub>2</sub>	9120	(40.57)	8135	(36.19)	53.25	(24.15)
16	(400)	1 <sup>5</sup> / <sub>8</sub>	(41.28)	12 <sup>1</sup> / <sub>8</sub>	(327.03)	10 <sup>3</sup> / <sub>4</sub>	(273.05)	1 <sup>1</sup> / <sub>2</sub>	9120	(40.57)	8135	(36.19)	58.46	(26.52)
18	(450)	3	(76.20)	17 <sup>1</sup> / <sub>4</sub>	(438.15)	14 <sup>1</sup> / <sub>2</sub>	(368.30)	2	13800	(61.39)	12280	(54.62)	132.16	(59.95)
20	(500)	3	(76.20)	18 <sup>3</sup> / <sub>4</sub>	(476.25)	16	(406.40)	2	15300	(68.06)	13620	(60.58)	153.84	(69.78)
24	(600)	3 <sup>1</sup> / <sub>4</sub>	(82.55)	21 <sup>1</sup> / <sub>2</sub>	(546.10)	18 <sup>1</sup> / <sub>2</sub>	(469.90)	2 <sup>1</sup> / <sub>4</sub>	16300	(72.51)	14500	(64.50)	219.80	(99.70)
28	(700)	3 <sup>1</sup> / <sub>4</sub>	(82.55)	23 <sup>1</sup> / <sub>2</sub>	(596.90)	20 <sup>1</sup> / <sub>2</sub>	(520.70)	2 <sup>1</sup> / <sub>4</sub>	18000	(80.07)	-	-	302.8	(137.35)
30	(750)	3 <sup>1</sup> / <sub>2</sub>	(88.90)	26	(660.40)	22 <sup>1</sup> / <sub>2</sub>	(571.50)	2 <sup>1</sup> / <sub>2</sub>	20500	(91.19)	-	-	365.4	(165.74)
32	(800)	3 <sup>1</sup> / <sub>2</sub>	(88.90)	27	(685.80)	23 <sup>1</sup> / <sub>2</sub>	(596.90)	2 <sup>1</sup> / <sub>2</sub>	23750	(105.65)	-	-	431.7	(195.82)
34	(850)	3 <sup>1</sup> / <sub>2</sub>	(88.90)	28 <sup>1</sup> / <sub>2</sub>	(723.90)	25	(635.00)	2 <sup>1</sup> / <sub>2</sub>	25000	(111.21)	-	-	533.8	(242.13)
36	(900)	3 <sup>1</sup> / <sub>2</sub>	(88.90)	30 <sup>1</sup> / <sub>4</sub>	(768.35)	26 <sup>1</sup> / <sub>2</sub>	(673.10)	2 <sup>3</sup> / <sub>4</sub>	28000	(124.55)	-	-	575.1	(260.86)
42	(1050)	3 <sup>1</sup> / <sub>2</sub>	(88.90)	33 <sup>3</sup> / <sub>4</sub>	(857.25)	30	(762.00)	2 <sup>3</sup> / <sub>4</sub>	35000	(155.69)	-	-	915.7	(415.35)

Unless otherwise specified, all dimensions on drawings and in charts are in inches and dimensions shown in parentheses are in millimeters.

# PIPE CLAMPS



## DOUBLE BOLT PIPE CLAMP

**FIG. 525**

- Function:** Designed for the suspension of high temperature insulated pipe lines. Normally used in conjunction with Fig. 35 weldless eye nut or Fig. 55 welded eye rod to allow flexibility at the rod attachment. The clamp can be used with up to 4 inches (101.6mm) of insulation and temperatures up to 750° F (399° C).
- Material:** Carbon steel (Type 304 or 316 Stainless Steel upon request)
- Finish:** Plain or electro-galvanized (Hot dipped galvanized with electro-galvanized hardware upon request)
- Approvals:** Complies with Federal Specification A-A-1192A (Type 3) and Manufacturers' Standardization Society ANSI/MSS SP-58 (Type 3) which supersedes ANSI/MSS SP-69.
- Ordering:** Specify figure number, pipe size, material, and finish.

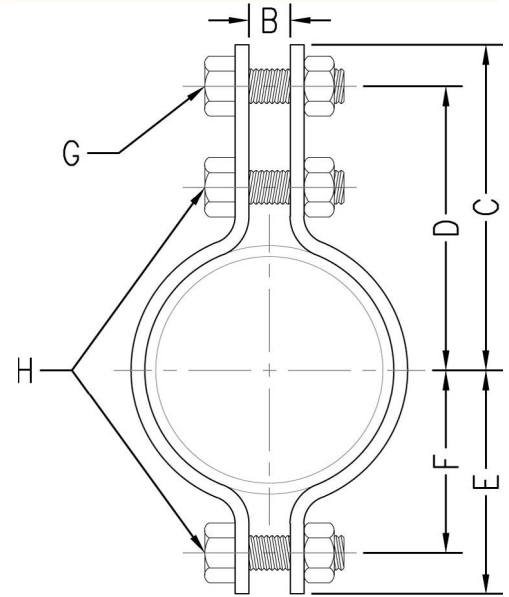

Pipe Size		B	C	D	E	F	Bolt Size		Max. Rec. Load				Wt. Each						
							G	H	650°F (343°C)		750°F (399°C)		lbs.	kg					
									lbs.	kN	lbs.	kN							
3/4	(20)	5/8	(15.88)	3 7/16	(87.31)	2 13/16	(71.44)	2	(50.80)	1 3/8	(34.93)	3/8	3/8	950	(4.23)	850	(3.78)	.83	(.38)
1	(25)	5/8	(15.88)	3 1/2	(88.90)	2 7/8	(73.03)	2	(50.80)	1 3/8	(34.93)	3/8	3/8	950	(4.23)	850	(3.78)	1.02	(.46)
1 1/4	(32)	5/8	(15.88)	3 9/16	(90.49)	2 15/16	(74.61)	2 1/16	(52.39)	1 7/16	(36.51)	3/8	3/8	950	(4.23)	850	(3.78)	1.07	(.49)
1 1/2	(40)	1	(25.40)	5 1/4	(133.35)	4 5/8	(117.48)	2 5/8	(66.68)	2	(50.80)	5/8	1/2	1545	(6.87)	1380	(6.14)	2.30	(1.04)
2	(50)	1	(25.40)	5 3/8	(136.53)	4 3/4	(120.65)	2 3/4	(69.85)	2 1/8	(53.98)	5/8	1/2	1545	(6.87)	1380	(6.14)	2.60	(1.18)
2 1/2	(65)	1	(25.40)	5 11/16	(144.46)	5 1/16	(128.59)	3 1/16	(77.79)	2 7/16	(61.91)	5/8	1/2	1545	(6.87)	1380	(6.14)	2.71	(1.23)
3	(80)	1	(25.40)	6	(152.40)	5 3/8	(136.53)	3 3/8	(85.73)	2 3/4	(69.85)	5/8	1/2	1545	(6.87)	1380	(6.14)	3.03	(1.37)
3 1/2	(90)	1	(25.40)	6 5/16	(160.34)	5 11/16	(144.46)	3 11/16	(93.66)	3 1/16	(77.79)	5/8	1/2	1545	(6.87)	1380	(6.14)	3.28	(1.49)
4	(100)	1	(25.40)	8 1/16	(204.79)	7 1/16	(179.39)	5 1/16	(128.59)	4 1/16	(103.19)	3/4	5/8	2500	(11.12)	2230	(9.92)	6.67	(3.03)
5	(125)	1	(25.40)	8 5/8	(219.08)	7 5/8	(193.68)	5 5/8	(142.88)	4 5/8	(117.48)	3/4	5/8	2500	(11.12)	2230	(9.92)	7.05	(3.20)
6	(150)	1 1/2	(38.10)	9 7/8	(250.83)	8 5/8	(219.08)	6 3/8	(161.93)	5 1/8	(130.18)	7/8	3/4	2865	(12.74)	2555	(11.37)	11.45	(5.19)
8	(200)	1 1/2	(38.10)	11 1/8	(282.58)	9 7/8	(250.83)	7 5/8	(193.68)	6 3/8	(161.93)	7/8	3/4	2865	(12.74)	2555	(11.37)	13.15	(5.96)
10	(250)	1 1/2	(38.10)	12 3/8	(314.33)	11 1/8	(282.58)	8 7/8	(225.43)	7 5/8	(193.68)	1	7/8	3240	(14.41)	2890	(12.86)	19.80	(8.98)
12	(300)	1 1/2	(38.10)	13 3/4	(349.25)	12 1/2	(317.50)	10 1/4	(260.35)	9	(228.60)	1	7/8	3240	(14.41)	2890	(12.86)	22.25	(10.09)
14	(350)	1 1/2	(38.10)	15 1/16	(382.59)	13 9/16	(344.49)	11 7/16	(290.51)	9 15/16	(252.41)	1 1/4	7/8	4300	(19.13)	3835	(17.06)	37.68	(17.09)
16	(400)	1 1/2	(38.10)	15 13/16	(401.64)	14 5/16	(363.54)	12 3/16	(309.56)	10 11/16	(271.46)	1 1/4	7/8	4300	(19.13)	3835	(17.06)	41.40	(18.78)
18	(450)	1 1/2	(38.10)	16 11/16	(423.86)	15 7/16	(392.11)	13 5/16	(338.14)	11 13/16	(300.04)	1 1/4	1	4300	(19.13)	3835	(17.06)	44.87	(20.35)
20	(500)	2	(50.80)	18	(457.20)	16 1/2	(419.10)	14 1/2	(368.30)	13	(330.20)	1 3/8	1 1/8	4500	(20.02)	4015	(17.86)	57.25	(25.97)
24	(600)	2	(50.80)	20 1/4	(514.35)	18 3/4	(476.25)	16 3/4	(425.45)	15 1/4	(387.35)	1 3/8	1 1/4	5490	(24.42)	4900	(21.80)	65.90	(29.89)

Unless otherwise specified, all dimensions on drawings and in charts are in inches and dimensions shown in parentheses are in millimeters.

# PIPE CLAMPS

**FIG. 526**

## HEAVY DUTY DOUBLE BOLT PIPE CLAMP

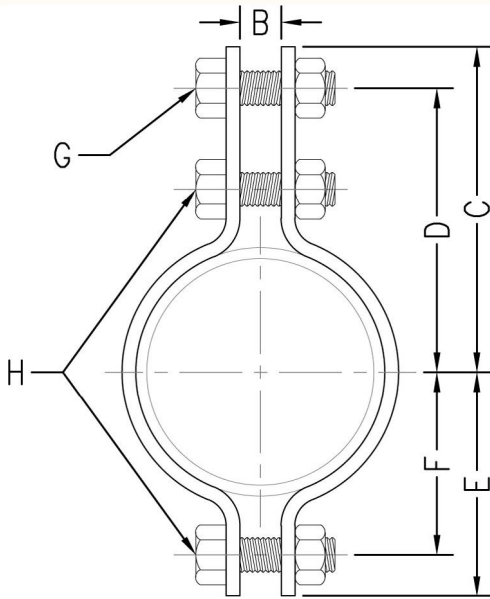

**Function:** Designed for the suspension of high temperature pipe lines. The increased material and bolt sizes allow Fig. 526 to be used in applications where heavier loads will be encountered. Normally used in conjunction with Fig. 35 weldless eye nut or Fig. 55 welded eye rod to allow flexibility at the rod attachment. The clamp can be used with up to 4 inches (101.6) of insulation and temperatures up to 750° F (399° C).

**Material:** Carbon steel (Type 304 or 316 Stainless Steel upon request)  
**Finish:** Plain or electro-galvanized (Hot dipped galvanized with electro-galvanized hardware upon request)

**Approvals:** Complies with Federal Specification A-A-1192A (Type 3) and Manufacturers' Standardization Society ANSI/MSS SP-58 (Type 3) which supersedes ANSI/MSS SP-69.

**Ordering:** Specify figure number, pipe size, material, and finish.

Pipe Size	B		C		D		E		F		Bolt Size		Max. Rec. Load				Wt. Each	
													650°F (343°C)		750°F (399°C)			
													lbs.	kN	lbs.	kN		
6 (150)	1 3/4	(44.45)	10 13/16	(274.64)	8 5/16	(227.01)	6	(152.40)	5 3/4	(146.05)	1	1	3500	(15.57)	3125	(13.90)	14.14	(6.41)
8 (200)	2	(50.80)	11 3/8	(288.93)	10 1/8	(257.18)	7 1/4	(184.15)	6	(152.40)	1 1/8	1	4800	(21.35)	4285	(19.06)	20.99	(9.52)
10 (250)	2 1/4	(57.15)	13 1/8	(333.38)	11 3/8	(288.93)	9	(228.60)	7 1/4	(184.15)	1 1/4	1 1/4	5500	(24.47)	4910	(21.84)	33.71	(15.29)
12 (300)	2 1/2	(63.50)	14 5/16	(363.54)	12 9/16	(319.09)	10 3/8	(263.53)	8 5/8	(219.08)	1 1/2	1 1/2	7000	(31.14)	6250	(27.80)	48.17	(21.85)
14 (350)	2 1/2	(63.50)	16	(406.40)	14	(355.60)	11 5/8	(295.28)	9 5/8	(244.48)	1 1/2	1 1/2	9500	(42.26)	8485	(37.74)	70.50	(31.98)
16 (400)	3	(76.20)	18	(457.20)	15 3/4	(400.05)	13 1/8	(333.38)	10 7/8	(276.23)	1 3/4	1 1/2	10000	(44.48)	8930	(39.72)	93.90	(42.59)
18 (450)	3 1/2	(88.90)	19 1/2	(495.30)	17 1/2	(444.50)	14 1/2	(368.30)	12 1/2	(317.50)	2	2	13800	(61.39)	12325	(54.82)	123.72	(56.12)
20 (500)	3 1/2	(88.90)	21 3/4	(552.45)	19 1/4	(488.95)	16	(406.40)	13 1/2	(342.90)	2	2	15300	(68.06)	13665	(60.78)	156.43	(70.96)
24 (600)	3 1/2	(88.90)	24 13/16	(630.24)	21 13/16	(554.04)	18 1/2	(469.90)	15 1/2	(393.70)	2	2	16300	(72.51)	14555	(64.74)	204.65	(92.83)
28 (700)	4	(101.60)	31 3/4	(806.45)	27 1/4	(692.15)	23 3/8	(593.73)	18 7/8	(479.43)	2 1/4	2 1/4	18000	(80.07)	16065	(71.46)	354.00	(160.57)
30 (750)	4 1/4	(107.95)	32 3/4	(831.85)	28 1/4	(717.55)	24 3/8	(619.13)	19 7/8	(504.83)	2 1/4	2 1/4	20500	(91.19)	18300	(81.40)	406.00	(184.16)
32 (800)	4 1/4	(107.95)	36	(914.40)	31	(787.40)	26 3/4	(679.45)	21 3/4	(552.45)	2 1/2	2 1/2	23750	(105.65)	-	-	555.00	(251.74)
34 (850)	4 1/4	(107.95)	37 1/2	(952.50)	32 1/2	(825.50)	28 3/8	(720.73)	23 3/8	(593.73)	2 1/2	2 1/2	25000	(111.21)	-	-	604.00	(273.97)
36 (900)	4 1/2	(114.30)	40 1/4	(1022.35)	34 3/4	(882.65)	30 1/8	(765.18)	24 5/8	(625.48)	2 3/4	2 3/4	28000	(124.55)	-	-	678.00	(307.54)

Unless otherwise specified, all dimensions on drawings and in charts are in inches and dimensions shown in parentheses are in millimeters.



# PIPE CLAMPS



## RISER CLAMP

**FIG. 550, 551, & 553**

**Function:** Designed for supporting and stabilizing vertical pipe runs. The PVC coating on Fig. 553 protects the pipe from the metal surface of the clamp. This product is not intended for use with hanger rods. Clamp is designed for standard iron pipe O.D. and must be considered when sizing other types of piping.

**Material:** Carbon steel (Type 304 or 316 Stainless Steel upon request)

**Finish:** Plain (**Fig. 550**), electro-galvanized (**Fig. 551**), or plain with PVC coating (**Fig. 553**), or (Hot dipped galvanized with electro-galvanized hardware upon request)

**Approvals:** Underwriters' Laboratories Listed in the U.S. (UL) and Canada (CUL), and Factory Mutual Approved for sizes 3/4" (20mm) to 8" (200mm) only. Fig. 553 is not UL or FM approved. Complies with Federal Specification A-A-1192A (Type 8) and Manufacturers' Standardization Society ANSI/MSS SP-58 (Type 8) which supersedes ANSI/MSS SP-69.

**Ordering:** Specify figure number, pipe size, material, and finish.

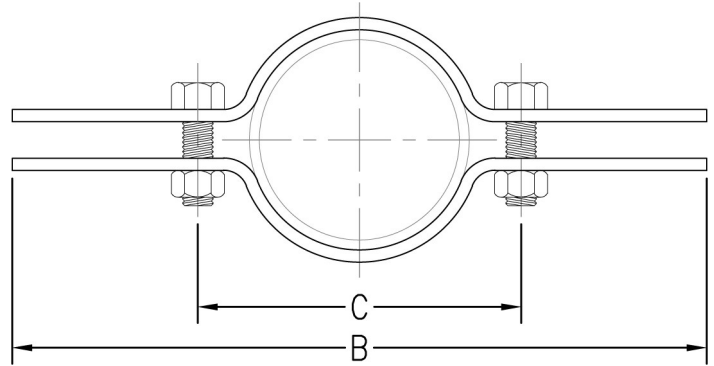

**Installation practice for Model 550 Riser Clamps:**  
When possible the clamp should be placed under a coupling, hub, or welded lugs on steel pipe. Bolt torques should be per industry standards.

Pipe Size		B		C		Bolt Size	Max. Rec. Load		Wt. Each	
							lbs.	kN	lbs.	kg
1/2	(15)	9	(228.60)	2 1/2	(63.50)	3/8 x 1 1/4	220	(0.98)	1.05	(.48)
3/4	(20)	8 7/8	(225.43)	2 3/8	(60.33)	3/8 x 1 1/4	220	(0.98)	1.05	(.48)
1	(25)	8 3/4	(222.25)	2 1/4	(57.15)	3/8 x 1 1/4	220	(0.98)	1.05	(.48)
1 1/4	(32)	9 1/4	(234.95)	2 3/4	(69.85)	3/8 x 1 1/4	250	(1.11)	1.10	(.50)
1 1/2	(40)	10	(254.00)	3 1/2	(88.90)	3/8 x 1 1/4	250	(1.11)	1.17	(.53)
2	(50)	10 1/4	(260.35)	3 3/4	(95.25)	3/8 x 1 1/4	300	(1.33)	1.20	(.54)
2 1/2	(65)	11 1/8	(282.58)	4 5/8	(117.48)	3/8 x 1 1/2	400	(1.78)	1.89	(.86)
3	(80)	11 3/4	(298.45)	5 1/4	(133.35)	3/8 x 1 1/2	500	(2.22)	1.99	(.90)
3 1/2	(90)	12 1/2	(317.50)	6	(152.40)	3/8 x 1 1/2	600	(2.67)	2.17	(.98)
4	(100)	13	(330.20)	6 1/2	(165.10)	1/2 x 1 3/4	750	(3.34)	2.21	(1.00)
5	(125)	14 1/4	(361.95)	7 3/4	(196.85)	1/2 x 1 3/4	1500	(6.67)	3.24	(1.47)
6	(150)	15 3/8	(390.53)	8 7/8	(225.43)	1/2 x 1 3/4	1600	(7.12)	3.89	(1.76)
8	(200)	18 1/2	(469.90)	12	(304.80)	5/8 x 2	2500	(11.12)	7.60	(3.45)
10	(250)	20 1/2	(520.70)	14	(355.60)	5/8 x 2	2500	(11.12)	11.10	(5.03)
12	(300)	22 1/2	(571.50)	16	(406.40)	5/8 x 2 1/2	2700	(12.01)	16.50	(7.48)
14	(350)	25 1/8	(638.18)	18 5/8	(473.08)	5/8 x 3	2700	(12.01)	17.70	(8.03)
16	(400)	26 1/4	(666.75)	20 3/4	(527.05)	3/4 x 3 1/2	2900	(12.90)	30.40	(13.79)
18	(450)	27 7/8	(708.03)	22 3/8	(568.33)	3/4 x 3 1/2	2900	(12.90)	33.30	(15.10)
20	(500)	30	(762.00)	24 1/2	(622.30)	3/4 x 3 1/2	2900	(12.90)	36.30	(16.47)
24	(600)	35	(889.00)	29 1/2	(749.30)	7/8 x 3 1/2	2900	(12.90)	48.68	(22.08)
30	(750)	42 3/8	(1076.33)	35 3/8	(898.52)	7/8 x 3 1/2	2900	(12.90)	60.16	(27.29)

Recommended Torque For Pipe Clamp Hardware						
Bolt Size	1/4"-20	5/16"-18	3/8"-16	1/2"-13	5/8"-11	3/4"-10 & Larger
ft-lbs.	6	11	19	50	65	75
N-m	(8)	(15)	(26)	(68)	(88)	(102)

Unless otherwise specified, all dimensions on drawings and in charts are in inches and dimensions shown in parentheses are in millimeters.

THREADED ACCESSORIES  
CPVC STRAPS  
BAND HANGERS  
BEAM CLAMPS  
CLEVIS HANGERS  
PIPE ROLLER SUPPORTS  
SPLIT RING HANGERS  
PIPE CLAMPS  
CENTER LOAD BEAM CLAMPS  
PIPE SHIELDS, INSULATION, & SADDLES  
PIPE GUIDES & SLIDES  
WALL BRACKETS  
PIPE SUPPORTS  
STRUCTURAL ATTACHMENTS  
SEISMIC BRACING

# PIPE CLAMPS

**FIG. 552 & 554**

## COPPER TUBING RISER CLAMP

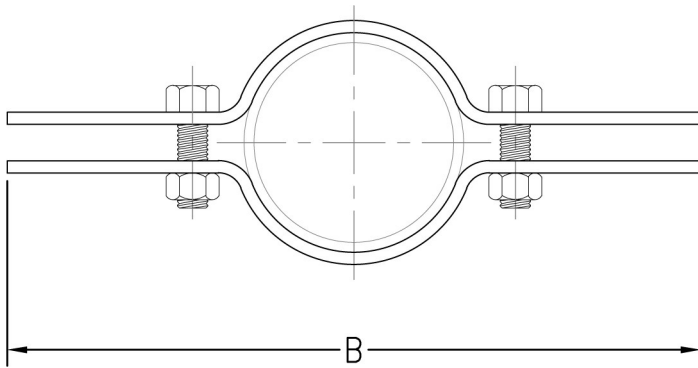

**Function:** Designed for supporting and stabilizing vertical tubing runs. The PVC coating on Fig. 554 protects the tube from the metal surface of the clamp.

**Material:** Carbon steel

**Finish:** Copper color epoxy (Fig. 552), or Copper color epoxy with PVC coating (Fig. 554)

**Approvals:** Complies with Federal Specification A-A-1192A (Type 8) and Manufacturers' Standardization Society ANSI/MSS SP-58 (Type 8) which supersedes ANSI/MSS SP-69.

**Ordering:** Specify figure number, pipe size, and finish.

**Installation practice for Model 550 Riser Clamps:**

When possible the clamp should be placed under a coupling, hub, or welded lugs on steel pipe. Bolt torques should be per industry standards.

Pipe Size		B		Bolt Size	Max. Rec. Load		Wt. Each	
					lbs.	kN	lbs.	kg
1/2	(15)	6 <sup>11/16</sup>	(169.86)	1/4	75	(.33)	.50	(.23)
3/4	(20)	7	(177.80)	1/4	75	(.33)	.52	(.24)
1	(25)	8 <sup>3/4</sup>	(222.25)	1/4	120	(.53)	.64	(.29)
1 <sup>1/4</sup>	(32)	9	(228.60)	1/4	150	(.67)	.65	(.29)
1 <sup>1/2</sup>	(40)	9 <sup>3/8</sup>	(238.13)	1/4	150	(.67)	.70	(.32)
2	(50)	9 <sup>15/16</sup>	(252.41)	3/8	150	(.67)	.98	(.44)
2 <sup>1/2</sup>	(65)	10 <sup>1/2</sup>	(266.70)	3/8	300	(1.33)	1.09	(.49)
3	(80)	11	(279.40)	3/8	300	(1.33)	1.17	(.53)
3 <sup>1/2</sup>	(90)	12 <sup>3/16</sup>	(309.56)	3/8	300	(1.33)	1.53	(.69)
4	(100)	12 <sup>5/8</sup>	(320.68)	3/8	300	(1.33)	1.67	(.76)
5	(125)	14 <sup>1/8</sup>	(358.78)	1/2	500	(2.22)	2.42	(1.10)
6	(150)	15	(381.00)	1/2	500	(2.22)	2.68	(1.22)

Recommended Torque For Pipe Clamp Hardware						
Bolt Size	1/4"-20	5/16"-18	3/8"-16	1/2"-13	5/8"-11	3/4"-10 & Larger
ft-lbs.	6	11	19	50	65	75
N-m	(8)	(15)	(26)	(68)	(88)	(102)

# PIPE CLAMPS



## INSULATION RISER CLAMP

## FIG. R087100 - R412150

**Function:** The patented Titan riser is made to fit insulated pipe and create a clean vapor barrier on vertical pipe runs. Klo-Shure Titan riser will dramatically improve the fit and finish of insulated tube and pipe runs.

**Material:** Carbon steel clamp. Cushion material is Washington Penn TPO in accordance with ASTM D 4000, TEO0120, A45000

**Finish:** Electro-galvanized

**Ordering:** Specify figure number.

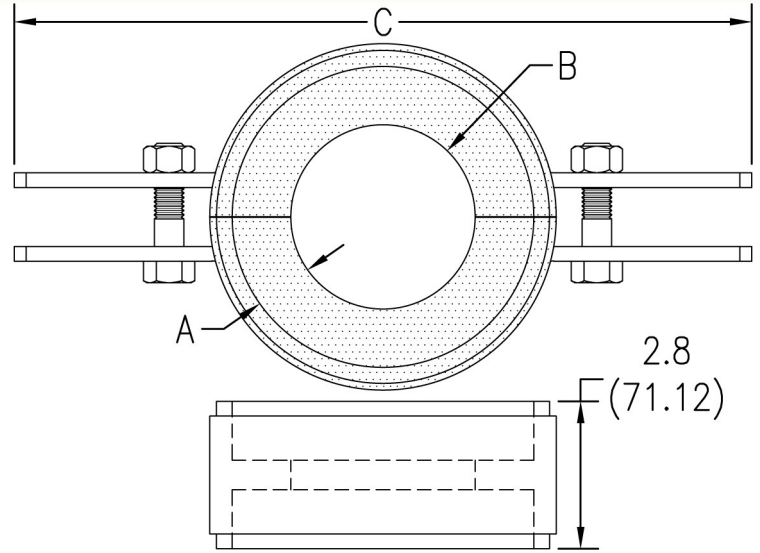

Fig. Number	Insulation Thickness A		B		C		Max. Rec. Load		Wt. Each	
							lbs.	kN	lbs.	kg
R087100	1	(25.4)	7/8	(22.23)	10.125	(257.18)	75	(0.33)	2.375	(1.08)
R112100	1	(25.4)	1 1/8	(28.58)	10.875	(276.23)	120	(0.53)	2.555	(1.16)
R137100	1	(25.4)	1 3/8	(34.93)	11.5	(292.10)	150	(0.67)	2.885	(1.31)
R162100	1	(25.4)	1 5/8	(41.28)	11.5	(292.10)	150	(0.67)	2.865	(1.30)
R212100	1	(25.4)	2 1/8	(53.98)	11.5	(292.10)	190	(0.85)	3.515	(1.59)
R262100	1	(25.4)	2 5/8	(66.68)	12.5	(317.50)	300	(1.33)	3.855	(1.75)
R312100	1	(25.4)	3 1/8	(79.38)	12.5	(317.50)	300	(1.33)	4.215	(1.91)
R412100	1	(25.4)	4 1/8	(104.78)	13.8	(350.52)	320	(1.42)	5.475	(2.48)
R087150	1 1/2	(38.1)	7/8	(22.23)	10.875	(276.23)	75	(0.33)	2.905	(1.32)
R112150	1 1/2	(38.1)	1 1/8	(28.58)	10.875	(276.23)	120	(0.53)	3.045	(1.38)
R137150	1 1/2	(38.1)	1 3/8	(34.93)	11.5	(292.10)	150	(0.67)	3.355	(1.52)
R162150	1 1/2	(38.1)	1 5/8	(41.28)	11.5	(292.10)	150	(0.67)	3.625	(1.64)
R212150	1 1/2	(38.1)	2 1/8	(53.98)	12	(304.80)	150	(0.67)	4.245	(1.93)
R262150	1 1/2	(38.1)	2 5/8	(66.68)	12	(304.80)	300	(1.33)	3.855	(1.75)
R312150	1 1/2	(38.1)	3 1/8	(79.38)	13	(330.20)	300	(1.33)	5.785	(2.62)
R412150	1 1/2	(38.1)	4 1/8	(104.78)	15.625	(396.88)	300	(1.33)	6.915	(3.14)

Load data based on 200 in-lb. torque

THREADED ACCESSORIES  
CPVC STRAPS  
BAND HANGERS  
BEAM CLAMPS  
CLEVIS HANGERS  
PIPE ROLLER SUPPORTS  
SPLIT RING HANGERS  
PIPE CLAMPS  
CENTER LOAD BEAM CLAMPS  
PIPE SHIELDS, INSULATION, & SADDLES  
PIPE GUIDES & SLIDES  
WALL BRACKETS  
PIPE SUPPORTS  
STRUCTURAL ATTACHMENTS  
SEISMIC BRACING

# PIPE CLAMPS

**FIG. 580**

## TWO BOLT UNDERGROUND PIPE CLAMP

**Function:** Designed for clamping the caulked joints of underground A.W.W.A. ductile iron water pipes to prevent separation of joints.

**Material:** Carbon steel (Type 304 or 316 Stainless Steel upon request)

**Finish:** Plain or electro-galvanized (Hot dipped galvanized with electro-galvanized hardware upon request)

**Ordering:** Specify figure number, pipe size, material, and finish. Order Fig. 585 washer separately.

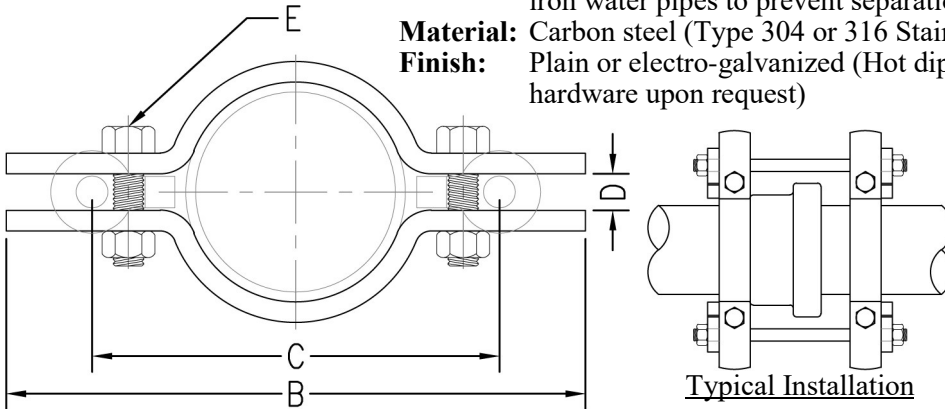

**NOTE:** Clamps must be connected by means of threaded tie rods and the nuts drawn tight on the washers to assure a tight joint.

Pipe Size	Max. Pipe O.D.	B		C		D		Bolt Size E	Rec. Tie Rod Size	Wt. Each	
										lbs.	kg
3 (80)	3.96 (100.58)	11 <sup>3</sup> / <sub>4</sub>	(298.45)	9	(228.60)	1 <sup>1</sup> / <sub>4</sub>	(31.75)	5/8 x 3	3/4	6.18	(2.80)
4 (100)	4.80 (121.92)	13	(330.20)	10 <sup>1</sup> / <sub>4</sub>	(260.35)	1 <sup>1</sup> / <sub>4</sub>	(31.75)	5/8 x 3	3/4	8.80	(3.99)
6 (150)	6.90 (175.26)	14 <sup>7</sup> / <sub>8</sub>	(377.83)	12	(304.80)	1 <sup>1</sup> / <sub>4</sub>	(31.75)	5/8 x 3	3/4	10.50	(4.76)
8 (200)	9.05 (229.87)	17 <sup>1</sup> / <sub>4</sub>	(438.15)	14 <sup>1</sup> / <sub>2</sub>	(368.30)	1 <sup>1</sup> / <sub>4</sub>	(31.75)	5/8 x 3	3/4	12.34	(5.60)
10 (250)	11.10 (281.94)	19 <sup>1</sup> / <sub>2</sub>	(495.30)	16 <sup>3</sup> / <sub>4</sub>	(425.45)	1 <sup>1</sup> / <sub>4</sub>	(31.75)	5/8 x 3	3/4	14.80	(6.71)
12 (300)	13.20 (335.28)	21 <sup>3</sup> / <sub>4</sub>	(552.45)	19	(482.60)	1 <sup>1</sup> / <sub>4</sub>	(31.75)	5/8 x 3 <sup>1</sup> / <sub>2</sub>	3/4	16.03	(7.27)
14 (350)	15.30 (388.62)	27 <sup>7</sup> / <sub>8</sub>	(708.03)	23 <sup>3</sup> / <sub>8</sub>	(593.73)	1 <sup>3</sup> / <sub>8</sub>	(34.93)	7/8 x 4	1	44.37	(20.13)
16 (400)	17.40 (441.96)	29 <sup>1</sup> / <sub>8</sub>	(739.77)	25 <sup>1</sup> / <sub>2</sub>	(647.70)	1 <sup>1</sup> / <sub>2</sub>	(38.10)	1 x 4 <sup>1</sup> / <sub>2</sub>	1 <sup>1</sup> / <sub>8</sub>	64.74	(29.37)
18 (450)	19.50 (495.30)	32 <sup>1</sup> / <sub>4</sub>	(819.15)	28	(711.20)	1 <sup>1</sup> / <sub>2</sub>	(38.10)	1 <sup>1</sup> / <sub>4</sub> x 4 <sup>1</sup> / <sub>2</sub>	1 <sup>1</sup> / <sub>4</sub>	73.69	(33.43)
20 (500)	21.60 (548.64)	33 <sup>1</sup> / <sub>4</sub>	(844.55)	29 <sup>3</sup> / <sub>4</sub>	(755.65)	1 <sup>5</sup> / <sub>8</sub>	(41.28)	1 <sup>1</sup> / <sub>4</sub> x 4 <sup>1</sup> / <sub>2</sub>	1 <sup>3</sup> / <sub>8</sub>	86.00	(39.01)
24 (600)	25.80 (655.32)	37 <sup>3</sup> / <sub>4</sub>	(958.85)	34	(863.60)	1 <sup>3</sup> / <sub>4</sub>	(44.45)	1 <sup>1</sup> / <sub>2</sub> x 5	1 <sup>1</sup> / <sub>2</sub>	113.00	(51.26)
30 (750)	32.00 (812.80)	45 <sup>1</sup> / <sub>8</sub>	(1146.18)	41 <sup>3</sup> / <sub>8</sub>	(1050.93)	2	(50.80)	1 <sup>1</sup> / <sub>2</sub> x 5 <sup>1</sup> / <sub>2</sub>	1 <sup>3</sup> / <sub>4</sub>	136.78	(62.04)
36 (900)	38.30 (972.82)	50 <sup>3</sup> / <sub>4</sub>	(1289.05)	46 <sup>1</sup> / <sub>2</sub>	(1181.10)	2 <sup>1</sup> / <sub>2</sub>	(63.50)	1 <sup>1</sup> / <sub>2</sub> x 5 <sup>1</sup> / <sub>2</sub>	1 <sup>3</sup> / <sub>4</sub>	155.50	(70.53)

**FIG. 585**

## WASHER (For Fig. 580)

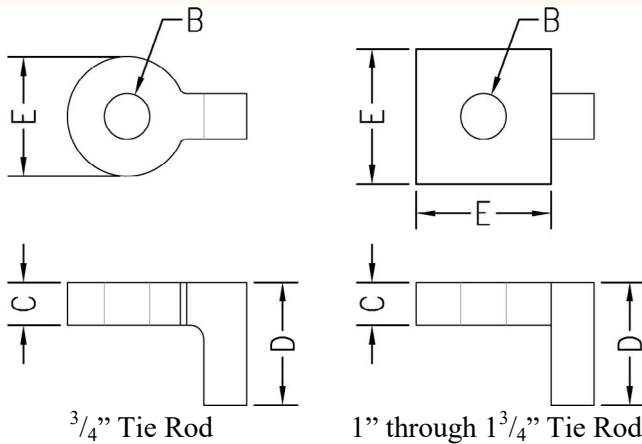

**Function:** Designed to secure tie rods when used in conjunction with Fig. 580 two bolt underground pipe clamp.

**Material:** Carbon steel (Type 304 or 316 Stainless Steel upon request). 3/4" tie rod size is only available in cast iron.

**Finish:** Plain or electro-galvanized (Hot dipped galvanized upon request)

**Ordering:** Specify figure number, tie rod size, material, and finish.

Tie Rod Size	Dia. B		C		D		E		For Pipe Sizes		Wt. Each	
											lbs.	kg
3/4	7/8	(22.23)	5/8	(15.88)	1 <sup>3</sup> / <sub>4</sub>	(44.45)	2 <sup>5</sup> / <sub>16</sub>	(58.74)	3 - 12	(80 - 300)	.80	(.36)
1	1 <sup>1</sup> / <sub>8</sub>	(28.58)	1/2	(12.70)	3	(76.20)	3 <sup>1</sup> / <sub>2</sub>	(88.90)	14	(350)	1.45	(.66)
1 <sup>1</sup> / <sub>8</sub>	1 <sup>1</sup> / <sub>4</sub>	(31.75)	5/8	(15.88)	3	(76.20)	4	(101.60)	16	(400)	2.31	(1.05)
1 <sup>1</sup> / <sub>4</sub>	1 <sup>3</sup> / <sub>8</sub>	(34.93)	5/8	(15.88)	3	(76.20)	4	(101.60)	18	(450)	2.26	(1.03)
1 <sup>3</sup> / <sub>8</sub>	1 <sup>1</sup> / <sub>2</sub>	(38.10)	3/4	(19.05)	3	(76.20)	4	(101.60)	20	(500)	2.87	(1.30)
1 <sup>1</sup> / <sub>2</sub>	1 <sup>5</sup> / <sub>8</sub>	(41.28)	3/4	(19.05)	3	(76.20)	4	(101.60)	24	(600)	2.71	(1.23)
1 <sup>3</sup> / <sub>4</sub>	1 <sup>7</sup> / <sub>8</sub>	(47.63)	1	(25.40)	3	(76.20)	4	(101.60)	30 - 36	(750 - 900)	4.17	(1.89)

Unless otherwise specified, all dimensions on drawings and in charts are in inches and dimensions shown in parentheses are in millimeters.

# PIPE CLAMPS



## FOUR BOLT UNDERGROUND PIPE CLAMP

**FIG. 590**

- Function:** Designed for clamping the caulked joints of underground A.W.W.A. ductile iron water pipe lines to prevent separation of joints.
- Material:** Carbon steel (Type 304 or 316 Stainless Steel upon request)
- Finish:** Plain or electro-galvanized (Hot dipped galvanized with electro-galvanized hardware upon request)
- Approvals:** Complies with National Fire Protection Association Standard 24 for 4" (100) thru 12" (300) pipe.
- Ordering:** Specify figure number, pipe size, material, and finish. Order Fig. 595 washer separately.

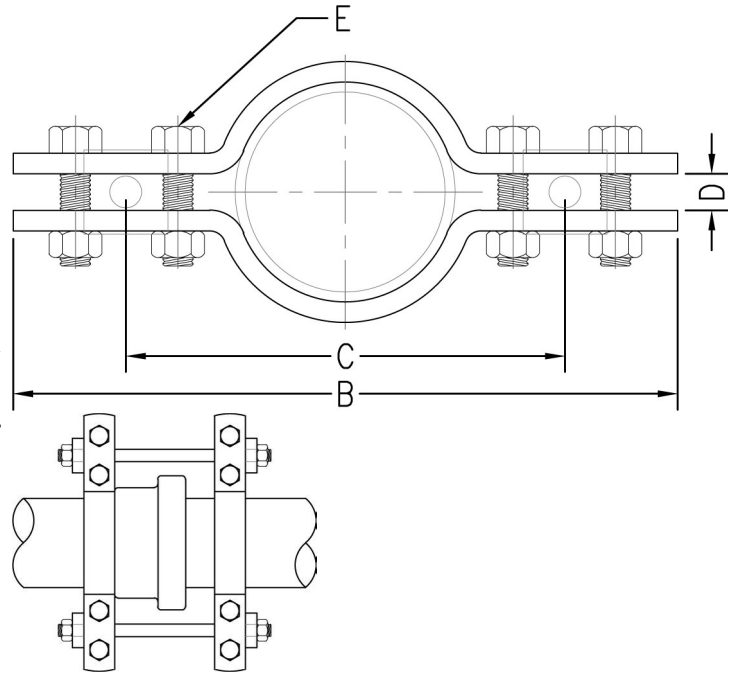

**Typical Installation**

*NOTE: Clamps must be connected by means of threaded tie rods and the nuts drawn tight on the washers to assure a tight joint.*

Pipe Size	Max. Pipe O.D.	B		C		D		Bolt Size E	Rec. Tie Rod Size	Max. Test Pressure		Force on Clamp		Wt. Each	
		in.	mm	in.	mm	in.	mm			PSI	kPa	lbs.	kN	lbs.	kg
4 (100)	4.80 (121.92)	14 <sup>9</sup> / <sub>8</sub> (371.48)	9 <sup>5</sup> / <sub>8</sub> (244.48)	1 <sup>1</sup> / <sub>4</sub> (31.75)	5 <sup>1</sup> / <sub>8</sub> x 3	3 <sup>4</sup> / <sub>4</sub>	250 (1722.5)	4550 (20.24)	12.8 (5.81)						
6 (150)	6.90 (175.26)	16 <sup>7</sup> / <sub>8</sub> (428.63)	11 <sup>7</sup> / <sub>8</sub> (301.63)	1 <sup>1</sup> / <sub>4</sub> (31.75)	5 <sup>1</sup> / <sub>8</sub> x 3	3 <sup>4</sup> / <sub>4</sub>	250 (1722.5)	9340 (41.55)	14.6 (6.62)						
8 (200)	9.05 (229.87)	19 <sup>1</sup> / <sub>8</sub> (485.78)	14 <sup>1</sup> / <sub>8</sub> (358.78)	1 <sup>1</sup> / <sub>4</sub> (31.75)	5 <sup>1</sup> / <sub>8</sub> x 3 <sup>1</sup> / <sub>2</sub>	3 <sup>4</sup> / <sub>4</sub>	250 (1722.5)	16080 (71.53)	23.6 (10.70)						
10 (250)	11.10 (281.94)	21 <sup>3</sup> / <sub>8</sub> (542.93)	16 <sup>5</sup> / <sub>8</sub> (422.28)	1 <sup>1</sup> / <sub>4</sub> (31.75)	3 <sup>4</sup> / <sub>4</sub> x 3 <sup>1</sup> / <sub>2</sub>	1	250 (1722.5)	24180 (107.56)	29.3 (13.29)						
12 (300)	13.20 (335.28)	25 <sup>1</sup> / <sub>8</sub> (638.18)	19 <sup>5</sup> / <sub>8</sub> (498.48)	1 <sup>1</sup> / <sub>4</sub> (31.75)	7 <sup>1</sup> / <sub>8</sub> x 4	1	250 (1722.5)	34230 (152.26)	40.3 (18.28)						
14 (350)	15.30 (388.62)	28 <sup>3</sup> / <sub>4</sub> (717.55)	22 <sup>3</sup> / <sub>8</sub> (568.33)	1 <sup>3</sup> / <sub>4</sub> (44.45)	7 <sup>1</sup> / <sub>8</sub> x 4 <sup>1</sup> / <sub>2</sub>	1 <sup>1</sup> / <sub>4</sub>	120 (826.8)	22200 (98.75)	53.9 (24.45)						
16 (400)	17.40 (441.96)	31 <sup>3</sup> / <sub>8</sub> (796.93)	25 <sup>3</sup> / <sub>8</sub> (644.53)	1 <sup>3</sup> / <sub>4</sub> (44.45)	1 x 4 <sup>1</sup> / <sub>2</sub>	1 <sup>1</sup> / <sub>4</sub>	115 (792.3)	27760 (123.48)	76.5 (34.70)						
18 (450)	19.50 (495.30)	35 <sup>1</sup> / <sub>8</sub> (892.18)	28 <sup>1</sup> / <sub>8</sub> (714.38)	1 <sup>3</sup> / <sub>4</sub> (44.45)	1 <sup>1</sup> / <sub>4</sub> x 4 <sup>1</sup> / <sub>2</sub>	1 <sup>1</sup> / <sub>4</sub>	100 (689.0)	23900 (106.31)	94.3 (42.77)						
20 (500)	21.60 (548.64)	37 <sup>3</sup> / <sub>4</sub> (958.85)	30 <sup>1</sup> / <sub>2</sub> (774.70)	1 <sup>3</sup> / <sub>4</sub> (44.45)	1 <sup>1</sup> / <sub>4</sub> x 4 <sup>1</sup> / <sub>2</sub>	1 <sup>3</sup> / <sub>8</sub>	75 (516.7)	27500 (122.33)	109.8 (49.80)						
24 (600)	25.80 (655.32)	44 <sup>1</sup> / <sub>4</sub> (1123.95)	36 (914.40)	1 <sup>3</sup> / <sub>4</sub> (44.45)	1 <sup>1</sup> / <sub>2</sub> x 5	1 <sup>1</sup> / <sub>2</sub>	50 (344.5)	26200 (116.54)	148.6 (67.40)						

## WASHER (For Fig. 590)

**FIG. 595**

- Function:** Designed to secure tie rods when used in conjunction with Fig. 590 four bolt underground pipe clamp.
- Material:** Carbon steel (Type 304 or 316 Stainless Steel upon request)
- Finish:** Plain or electro-galvanized (Hot dipped galvanized upon request)
- Ordering:** Specify figure number, tie rod size, material, and finish.

Tie Rod Size	Dia. B	C	D	For Pipe Sizes	Wt. Each	
					lbs.	kg
3/4	7/8 (22.23)	1/2 (12.70)	3 (76.20)	4 - 8 (100 - 200)	1.19 (.54)	
1	1 1/8 (28.58)	1/2 (12.70)	3 1/2 (88.90)	10 - 12 (250 - 300)	1.49 (.68)	
1 1/4	1 3/8 (34.93)	3/4 (19.05)	3 1/2 (88.90)	14 - 18 (350 - 450)	2.15 (.98)	
1 3/8	1 1/2 (38.10)	3/4 (19.05)	3 1/2 (88.90)	20 (500)	1.92 (.87)	
1 1/2	1 5/8 (41.28)	3/4 (19.05)	3 1/2 (88.90)	24 (600)	1.85 (.84)	

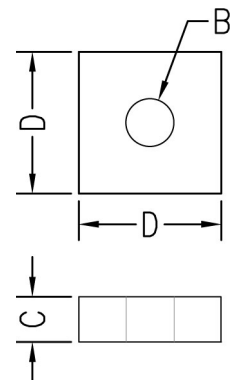

Unless otherwise specified, all dimensions on drawings and in charts are in inches and dimensions shown in parentheses are in millimeters.

# PIPE CLAMPS

## FIG. 825 & 826

## TWO HOLE STRAP

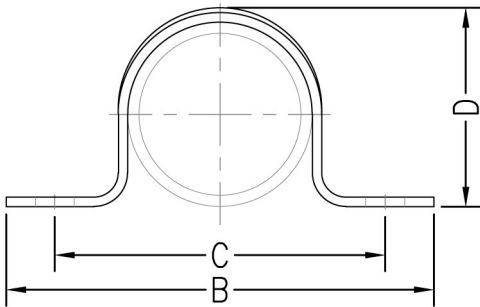

- Function:** Designed to hold pipe/conduit (**Fig. 825**) or copper tubing (**Fig. 826**) flush with mounting surface for light duty applications.
- Material:** Carbon steel
- Finish:** Electro-galvanized (**Fig. 825**) or copper plated (**Fig. 826**)
- Ordering:** Specify figure number and pipe, conduit, or copper tubing size.

Fig. 825									
Pipe Size		B		C		D		Wt. Each	
								lbs.	kg
1/4	(6)	1 5/8	(41.28)	1 1/8	(28.58)	5/8	(15.88)	.01	(.01)
3/8	(10)	2 3/8	(60.33)	1 5/8	(41.28)	1 1/16	(17.46)	.03	(.01)
1/2	(15)	2 5/8	(66.68)	1 7/8	(47.63)	7/8	(22.23)	.04	(.02)
3/4	(20)	2 3/4	(69.85)	2 1/8	(53.98)	1 1/8	(28.58)	.05	(.02)
1	(25)	3 3/8	(85.73)	2 5/8	(66.68)	1 7/16	(36.51)	.06	(.03)
1 1/4	(32)	4 1/4	(107.95)	3 3/16	(80.96)	1 13/16	(46.04)	.08	(.04)
1 1/2	(40)	4 1/2	(114.30)	3 1/2	(88.90)	1 15/16	(49.21)	.10	(.05)
2	(50)	5 3/8	(136.53)	4 1/8	(104.78)	2 9/16	(65.09)	.13	(.06)
2 1/2	(65)	6	(152.40)	4 1/2	(114.30)	3 1/16	(77.79)	.20	(.09)
3	(80)	7 1/4	(184.15)	5 3/4	(146.05)	3 3/4	(95.25)	.50	(.23)
4	(100)	8 3/8	(212.73)	5 3/4	(146.05)	4 11/16	(119.06)	.51	(.23)

Fig. 826									
Tube Size		B		C		D		Wt. Each	
								lbs.	kg
1/4	(6)	1 5/8	(41.28)	1 1/8	(28.58)	3/8	(9.53)	.01	(.01)
3/8	(10)	1 13/16	(46.04)	1 5/16	(33.34)	1/2	(12.70)	.01	(.01)
1/2	(15)	1 15/16	(49.21)	1 7/16	(36.51)	5/8	(15.88)	.01	(.01)
3/4	(20)	2 1/4	(57.15)	1 3/4	(44.45)	7/8	(22.23)	.01	(.01)
1	(25)	2 3/4	(69.85)	2 1/4	(57.15)	1 1/8	(28.58)	.01	(.01)
1 1/4	(32)	2 5/8	(66.68)	2 1/8	(53.98)	1 3/8	(34.93)	.04	(.02)
1 1/2	(40)	2 7/8	(73.03)	2 3/8	(60.33)	1 5/8	(41.28)	.05	(.02)
2	(50)	3 3/8	(85.73)	2 7/8	(73.03)	2 1/8	(53.98)	.05	(.02)

## FIG. 830

## SHORT PIPE STRAP

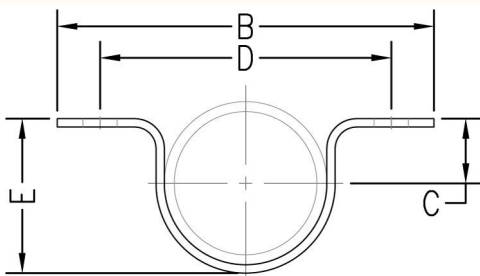

- Function:** Designed to hold pipe flush with mounting surface.
- Material:** Carbon steel (Type 304 or 316 Stainless Steel upon request)
- Finish:** Plain or electro-galvanized (Hot dipped galvanized upon request)
- Approvals:** Complies with Federal Specification A-A-1192A (Type 26) and Manufacturers' Standardization Society ANSI/MSS SP-58 (Type 26) which supersedes ANSI/MSS SP-69.
- Ordering:** Specify figure number, pipe size, material, and finish.

Pipe Size		B		C		D		E		Hole Size		Max. Rec. Load		Wt. Each	
												lbs.	kN	lbs.	kg
1/2	(15)	3 7/8	(98.43)	5/16	(7.94)	2 7/8	(73.03)	1 5/16	(23.81)	7/16	(11.11)	300	(1.33)	0.25	(.11)
3/4	(20)	4 1/16	(103.19)	7/16	(11.11)	3 1/16	(77.79)	1 1/8	(28.58)	7/16	(11.11)	300	(1.33)	0.27	(.12)
1	(25)	4 5/16	(109.54)	9/16	(14.29)	3 5/16	(84.14)	1 3/8	(34.93)	7/16	(11.11)	300	(1.33)	0.29	(.13)
1 1/4	(32)	4 11/16	(119.06)	1 1/16	(17.46)	3 11/16	(93.66)	1 5/8	(41.28)	7/16	(11.11)	300	(1.33)	0.33	(.15)
1 1/2	(40)	4 15/16	(125.41)	1 3/16	(20.64)	3 15/16	(100.01)	2	(50.80)	7/16	(11.11)	300	(1.33)	0.35	(.16)
2	(50)	5 1/2	(139.70)	1 5/16	(23.81)	4 1/2	(114.30)	2 1/4	(57.15)	7/16	(11.11)	300	(1.33)	0.41	(.19)
2 1/2	(65)	6	(152.40)	1 3/16	(30.16)	5	(127.00)	2 7/8	(73.03)	7/16	(11.11)	500	(2.22)	0.89	(.40)
3	(80)	6 5/8	(168.28)	1 1/2	(38.10)	5 5/8	(142.88)	3 1/2	(88.90)	7/16	(11.11)	500	(2.22)	1.06	(.48)
3 1/2	(90)	7 1/8	(180.98)	1 3/4	(44.45)	6 1/8	(155.58)	4	(101.60)	7/16	(11.11)	500	(2.22)	1.23	(.56)
4	(100)	8 3/8	(212.73)	2	(50.80)	7 1/8	(180.98)	4 1/2	(114.30)	9/16	(14.29)	500	(2.22)	1.58	(.72)

Unless otherwise specified, all dimensions on drawings and in charts are in inches and dimensions shown in parentheses are in millimeters.

# PIPE CLAMPS



## ONE HOLE STRAP

- Function:** Designed for the support of standard steel pipe (**Fig. 835**), copper tube (**Fig. 836**), or EMT conduit (**Fig. 837**) on walls or sides of beams. Not recommended for use horizontally, on ceilings, or bottoms of beams.
- Material:** Carbon steel (Type 304 or 316 Stainless Steel upon request for Fig. 835, & Fig. 837)
- Finish:** Electro-galvanized (**Fig. 835 & Fig. 837**) & copper plated (**Fig. 836**)
- Ordering:** Specify figure number, pipe, tube, or EMT size, material, and finish.

**FIG. 835, 836, & 837**

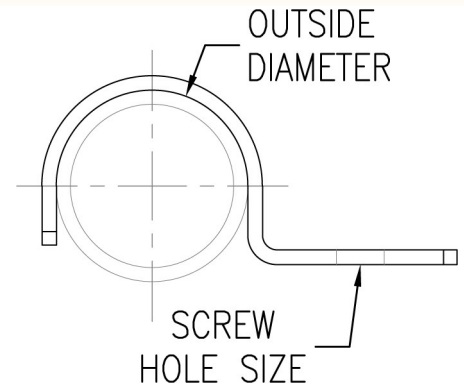

Fig. 835							
Pipe Size		Outside Diameter		Screw Hole Size		Wt. Each	
						lbs.	kg
1/2	(15)	.84	(21.34)	9/32	(7.14)	.06	(.03)
3/4	(20)	1.05	(26.67)	9/32	(7.14)	.10	(.05)
1	(25)	1.32	(33.27)	9/32	(7.14)	.10	(.05)
1 1/4	(32)	1.66	(42.16)	1 1/32	(8.73)	.13	(.06)
1 1/2	(40)	1.90	(48.26)	1 3/32	(10.32)	.20	(.09)
2	(50)	2.38	(60.20)	1 3/32	(10.32)	.25	(.11)
2 1/2	(65)	2.88	(72.90)	9/16	(14.29)	.50	(.23)
3	(80)	3.50	(88.90)	9/16	(14.29)	1.00	(.45)
4	(100)	4.50	(114.30)	9/16	(14.29)	1.50	(.68)

Fig. 836							
Tube Size		Outside Diameter		Screw Hole Size		Wt. Each	
						lbs.	kg
1/8	(3)	.25	(6.35)	3/16	(4.76)	.01	(.01)
1/4	(6)	.38	(9.53)	3/16	(4.76)	.02	(.01)
3/8	(10)	.50	(12.70)	9/32	(7.14)	.02	(.01)
1/2	(15)	.63	(15.88)	9/32	(7.14)	.03	(.01)
3/4	(20)	.88	(22.23)	9/32	(7.14)	.06	(.03)
1	(25)	1.13	(28.58)	9/32	(7.14)	.07	(.03)
1 1/4	(32)	1.38	(34.93)	9/32	(7.14)	.09	(.04)
1 1/2	(40)	1.63	(41.28)	5/16	(7.94)	.13	(.06)
2	(50)	2.13	(53.98)	3/8	(9.53)	.20	(.09)

Fig. 837							
EMT Size		Outside Diameter		Screw Hole Size		Wt. Each	
						lbs.	kg
1/2	(15)	.71	(18.03)	9/32	(7.14)	.06	(.03)
3/4	(20)	.92	(23.37)	9/32	(7.14)	.10	(.05)
1	(25)	1.16	(29.46)	9/32	(7.14)	.10	(.05)
1 1/4	(32)	1.51	(38.35)	1 1/32	(8.73)	.13	(.06)
1 1/2	(40)	1.74	(44.20)	1 3/32	(10.32)	.20	(.09)
2	(50)	2.20	(55.88)	1 3/32	(10.32)	.25	(.11)
2 1/2	(65)	2.88	(72.90)	9/16	(14.29)	.50	(.23)
3	(80)	3.50	(88.90)	9/16	(14.29)	1.00	(.45)
4	(100)	4.50	(114.30)	9/16	(14.29)	1.50	(.68)

Note: Sizes 1/2 -1 snap on.

## RIGHT ANGLE CLAMP

**FIG. 840**

- Function:** Designed for anchoring pipe or conduit at a right angle to structural members.
- Material:** Malleable iron with carbon steel U-bolt and nuts (Type 316 Stainless Steel upon request)
- Finish:** Hot dipped galvanized
- Ordering:** Specify figure number and pipe size.

NOTE: 5/8" (15.88) maximum flange thickness.

Pipe Size		Rod Size A	B		Wt. Each	
					lbs.	kg
*1/2	(15)	5/16	1 3/16	(30.16)	.41	(.19)
3/4	(20)	5/16	1 3/8	(34.93)	.42	(.19)
1	(25)	5/16	1 5/8	(41.28)	.47	(.21)
1 1/4	(32)	5/16	2 1/16	(52.39)	.54	(.24)
1 1/2	(40)	5/16	2 3/8	(60.33)	.57	(.26)
2	(50)	3/8	2 13/16	(71.44)	.85	(.39)
2 1/2	(65)	3/8	3 7/16	(87.31)	1.06	(.48)
3	(80)	3/8	4 1/16	(103.19)	1.10	(.50)
3 1/2	(90)	3/8	4 9/16	(115.89)	1.28	(.58)
4	(100)	3/8	5 1/16	(128.59)	1.40	(.64)

\* 3/8" (9.53) maximum flange thickness

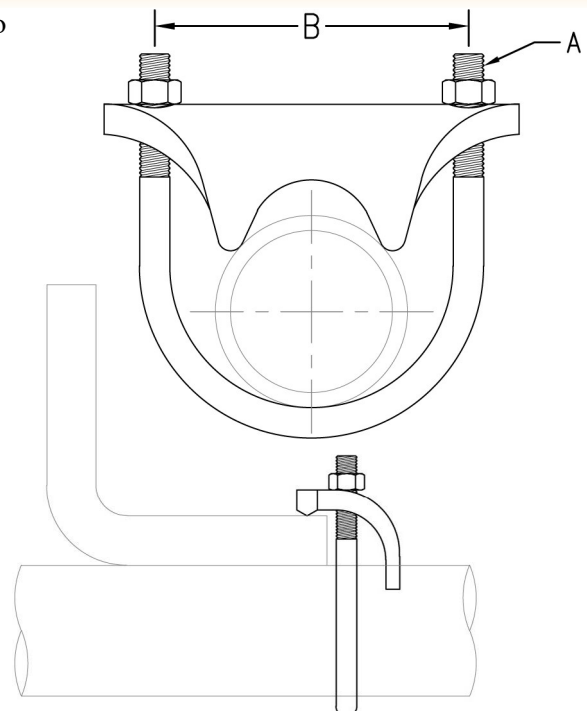

Unless otherwise specified, all dimensions on drawings and in charts are in inches and dimensions shown in parentheses are in millimeters.

# CENTER LOAD BEAM CLAMPS

**FIG. 610**

## STANDARD DUTY CENTER LOAD BEAM CLAMP

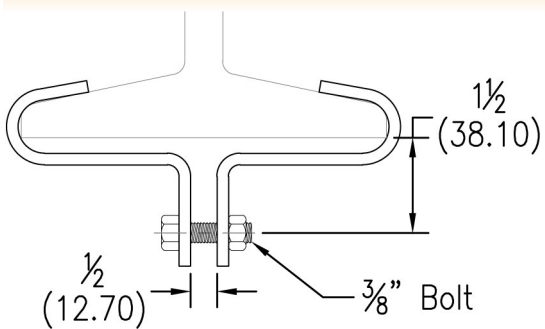

**Function:** Designed to be used in the suspension of a hanger rod from the center of an I-beam. The clamp's design allows the load to be distributed equally on either side of the beam. Normally used in conjunction with Fig. 50 eye rod, Fig. 55 welded eye rod, or Fig. 35 weldless eye nut.

**Material:** Carbon steel (Type 304 or 316 Stainless Steel upon request)  
**Finish:** Plain or electro-galvanized (Hot dipped galvanized with electro-galvanized hardware upon request)

**Approvals:** Complies with Federal Specification A-A-1192A (Type 21) and Manufacturers' Standardization Society ANSI/MSS SP-58 (Type 21) which supersedes ANSI/MSS SP-69.

**Ordering:** Specify figure number, flange width, material, and finish.

Flange Width		Max. Flange Thickness		Max. Rec. Load		Wt. Each	
				lbs.	kg	lbs.	kg
3	(76.2)	7/16	(11.11)	1000	(4.45)	.85	(.39)
4	(101.6)	1/2	(12.70)	1000	(4.45)	.88	(.40)
5	(127.0)	5/8	(15.88)	1000	(4.45)	1.10	(.50)
6	(152.4)	3/4	(19.05)	1000	(4.45)	1.13	(.51)
7	(177.8)	7/8	(22.23)	1000	(4.45)	1.23	(.56)
8	(203.2)	7/8	(22.23)	1000	(4.45)	1.25	(.57)
9	(228.6)	1	(25.40)	1000	(4.45)	1.43	(.65)
10	(254.0)	1	(25.40)	1000	(4.45)	1.52	(.69)
11	(279.4)	1	(25.40)	1000	(4.45)	1.63	(.74)
12	(304.8)	1 1/4	(31.75)	1000	(4.45)	1.71	(.78)

*NOTE: Spacer is furnished for use with Fig. 35 weldless eye nuts. Spacer may be removed for use with Fig. 50 eye rod or Fig. 55 welded eye rod.*

**FIG. 620**

## HEAVY DUTY CENTER LOAD BEAM CLAMP

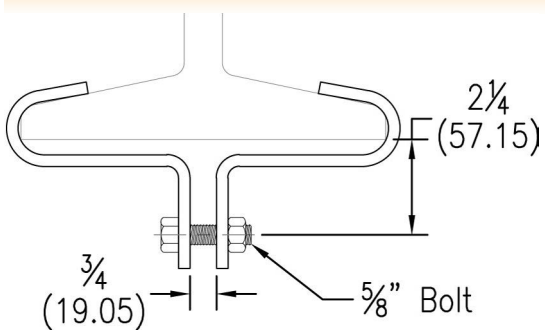

**Function:** Designed to be used in the suspension of a hanger rod from the center of an I-beam. The clamp's design allows the load to be distributed equally on either side of the beam. Normally used in conjunction with Fig. 55 welded eye rod or Fig. 35 weldless eye nut.

**Material:** Carbon steel (Type 304 or 316 Stainless Steel upon request)  
**Finish:** Plain or electro-galvanized (Hot dipped galvanized with electro-galvanized hardware upon request)

**Approvals:** Complies with Federal Specification A-A-1192A (Type 21) and Manufacturers' Standardization Society ANSI/MSS SP-58 (Type 21) which supersedes ANSI/MSS SP-69.

**Ordering:** Specify figure number, flange width, material, and finish.

Flange Width		Max. Flange Thickness		Max. Rec. Load		Wt. Each	
				lbs.	kg	lbs.	kg
4	(101.6)	1/2	(12.70)	3000	(13.34)	3.92	(1.78)
5	(127.0)	5/8	(15.88)	3000	(13.34)	4.28	(1.94)
6	(152.4)	3/4	(19.05)	3000	(13.34)	4.45	(2.02)
7	(177.8)	7/8	(22.23)	3000	(13.34)	4.76	(2.16)
8	(203.2)	7/8	(22.23)	3000	(13.34)	5.25	(2.38)
9	(228.6)	1	(25.40)	3000	(13.34)	5.73	(2.60)
10	(254.0)	1	(25.40)	3000	(13.34)	5.94	(2.69)
11	(279.4)	1	(25.40)	3000	(13.34)	6.53	(2.96)
12	(304.8)	1 1/4	(31.75)	3000	(13.34)	6.97	(3.16)

*NOTE: Spacer is furnished for use with Fig. 35 weldless eye nuts. Spacer may be removed for use with Fig. 50 eye rod or Fig. 55 welded eye rod.*



# CENTER LOAD BEAM CLAMPS



## STEEL CENTER LOAD BEAM CLAMP

**FIG. 625**

- Function:** Designed to be used in the suspension of a hanger rod from the center of an I-beam. The clamp provides a vertical adjustment of approximately 2" (50.8).
- Material:** Carbon steel (Type 304 or 316 Stainless Steel upon request)
- Finish:** Plain or electro-galvanized (Hot dipped galvanized with electro-galvanized hardware upon request)
- Ordering:** Specify figure number, rod size, flange width, material, and finish.

*NOTE: Box style furnished on some sizes.*

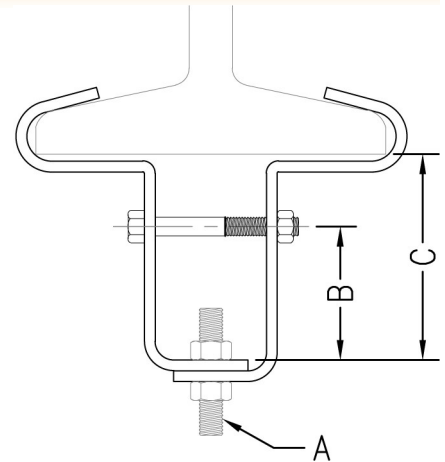

Rod Size A	B		C		Max. Rec. Load		Wt. Each															
							Flange Width															
							4 (101.6)		5 (127.0)		6 (152.4)		7 (177.4)		8 (203.2)		10 (254.2)		12 (304.8)			
lbs.	kg	lbs.	kg	lbs.	kg	lbs.	kg	lbs.	kg	lbs.	kg	lbs.	kg	lbs.	kg							
3/8	3	(76.20)	4	(101.60)	550	(2.45)	1.68	(.76)	1.81	(.82)	1.93	(.88)	2.05	(.93)	2.14	(.97)	2.35	(1.07)	2.59	(1.17)		
1/2	3	(76.20)	4	(101.60)	850	(3.78)	2.01	(.91)	2.17	(.98)	2.31	(1.05)	2.46	(1.12)	2.56	(1.16)	2.82	(1.28)	3.11	(1.41)		
5/8	3 1/4	(82.55)	4 1/2	(114.30)	1100	(4.89)	3.28	(1.49)	3.52	(1.60)	3.73	(1.69)	3.95	(1.79)	4.11	(1.86)	4.49	(2.04)	4.93	(2.24)		
3/4	3 1/4	(82.55)	4 1/2	(114.30)	1500	(6.67)	4.34	(1.97)	4.66	(2.11)	4.95	(2.25)	5.25	(2.38)	5.46	(2.48)	5.96	(2.70)	6.55	(2.97)		
7/8	3 1/2	(88.90)	5	(127.00)	2600	(11.57)	6.57	(2.98)	6.67	(3.03)	7.05	(3.20)	7.44	(3.37)	7.73	(3.51)	8.40	(3.81)	9.18	(4.16)		
1	3 1/2	(88.90)	5	(127.00)	4300	(19.13)	7.97	(3.62)	8.24	(3.74)	8.77	(3.98)	9.26	(4.20)	9.62	(4.36)	10.46	(4.74)	11.43	(5.18)		
1 1/8	3 1/2	(88.90)	5 1/2	(139.70)	6100	(27.13)	14.46	(6.56)	13.69	(6.21)	13.74	(6.23)	15.07	(6.84)	15.60	(7.08)	16.86	(7.65)	18.32	(8.31)		
1 1/4	3 1/2	(88.90)	5 1/2	(139.70)	8000	(35.59)	18.76	(8.51)	18.17	(8.24)	18.45	(8.37)	19.82	(8.99)	20.36	(9.24)	22.21	(10.07)	24.18	(10.97)		

## MALLEABLE IRON CENTER LOAD BEAM CLAMP

**FIG. 630**

- Function:** Designed to be used in the suspension of a hanger rod from the center of an I-beam. The clamp's design allows the load to be distributed equally on either side of the beam. The clamp is adjustable from 2 3/8" (60.33) to 7" (177.8) and can be used with flange thicknesses up to .60 inches (15.24). Normally used in conjunction with Fig. 25 extension piece. An additional 1" (25.4) or more of vertical adjustment is obtained when used with Fig 25.
- Material:** Malleable iron
- Finish:** Plain or electro-galvanized
- Approvals:** Complies with Federal Specification A-A-1192A (Type 30) and Manufacturers' Standardization Society ANSI/MSS SP-58 (Type 30) which supersedes ANSI/MSS SP-69.
- Ordering:** Specify figure number, and finish. If extension piece is required, order Fig. 25 extension piece separately.

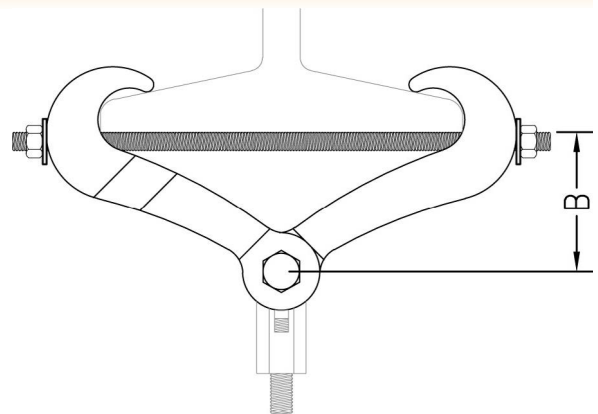

Max Rod Size	'B' Rod Take Out (Clamp Only)										Max. Rec. Load		Wt. Each	
	Beam Flange Width													
	2 3/8 (60.33)	3 (76.2)	4 (101.6)	5 (127.0)	6 (152.4)	7 (177.4)	lbs.	kN	lbs.	kg				
7/8	3 1/2 (88.90)	3 7/16 (87.31)	3 5/16 (84.14)	2 15/16 (74.61)	2 9/16 (65.09)	1 7/8 (47.63)	1365	(6.07)	2.49	(1.13)				

Unless otherwise specified, all dimensions on drawings and in charts are in inches and dimensions shown in parentheses are in millimeters.

THREADED ACCESSORIES  
CPVC STRAPS  
BAND HANGERS  
BEAM CLAMPS  
CLEVIS HANGERS  
PIPE ROLLER SUPPORTS  
SPLIT RING HANGERS  
PIPE CLAMPS  
CENTER LOAD BEAM CLAMPS  
PIPE SHIELDS, INSULATION, & SADDLES  
PIPE GUIDES & SLIDES  
WALL BRACKETS  
PIPE SUPPORTS  
STRUCTURAL ATTACHMENTS  
SEISMIC BRACING

# CENTER LOAD BEAM CLAMPS

**FIG. 632 & 633**

## STEEL CENTER LOAD BEAM CLAMP

**Function:** Designed to be used in the suspension of a hanger rod from the center of an I-beam. The clamp's design allows the load to be distributed equally on either side of the beam. The clamp is adjustable and normally used in conjunction with Fig. 35 weldless eye nut. An additional 1" (25.4) or more of vertical adjustment is obtained when used with Fig 35.

**Material:** Carbon steel (Type 304 or 316 Stainless Steel upon request)

**Finish:** Plain or electro-galvanized (Hot dipped galvanized with electro-galvanized hardware upon request)

**Approvals:** Complies with Federal Specification A-A-1192A (Type 28 without links) (Type 29 with links) and Manufacturers' Standardization Society ANSI/MSS SP-58 (Type 28 without links) (Type 29 with links) which supersedes ANSI/MSS SP-69.

**Ordering:** Specify figure number, type size, material, and finish.

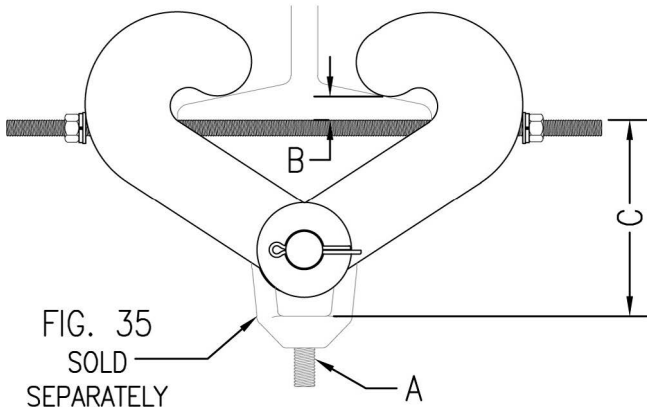

**Fig. 632 (without links)**

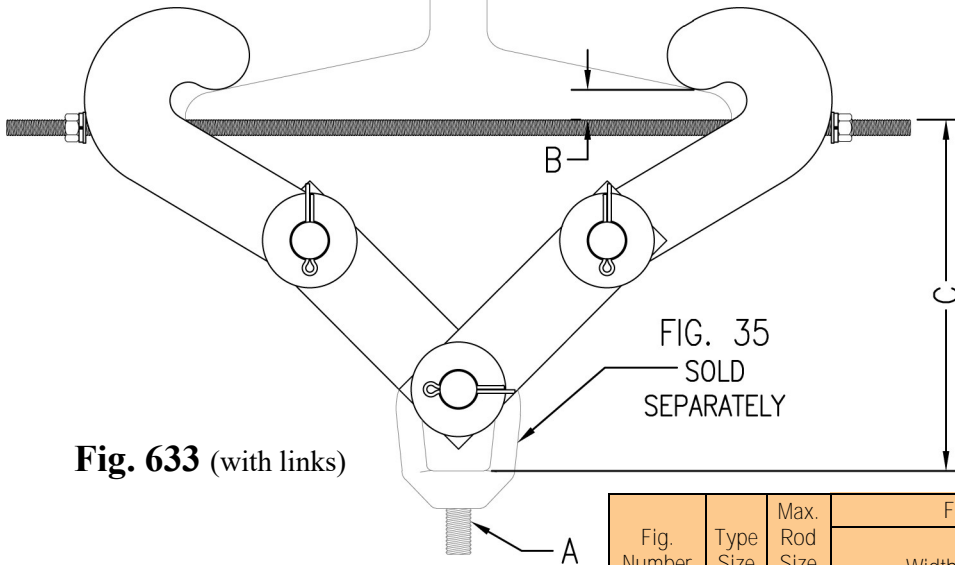

**Fig. 633 (with links)**

Fig. Number	Type Size	Max. Rod Size A	Flange Size		Max. Rec. Load		Appx. Wt. Each			
			Width	Max. Thickness B	lbs.	kN	lbs.	Kg		
632	A	1	3-8	(76.2-203.2)	3/4	(19.05)	5000	(22.24)	9.8	(4.42)
632	B	1 1/2	5-11	(127.0-279.4)	1	(25.40)	11500	(51.15)	25.0	(11.35)
633	A	1	7-15	(177.8-381.0)	3/4	(19.05)	5000	(22.24)	13.5	(6.12)
633	B	1 1/2	8-16	(203.2-406.4)	1	(25.40)	11500	(51.15)	33.1	(15.01)

Based on allowable stresses shown in ANSI Code for Pressure Piping

Fig. Number	Type Size	Rod Take-out for Width of Beam Flange with Max. Rod Size C													
		3 (76.2)		4 (101.6)		5 (127.0)		6 (152.4)		7 (177.8)		8 (203.2)		9 (228.6)	
632	A	5 3/16	(131.76)	5 1/8	(130.18)	5	(127.00)	4 13/16	(122.24)	4 3/8	(111.13)	3 15/16	(100.01)	--	--
632	B	--	--	--	--	7 1/2	(190.50)	7	(177.80)	6 3/4	(171.45)	6 1/2	(165.10)	6 1/4	(158.75)
633	A	--	--	--	--	--	--	--	--	9 1/2	(241.30)	9 3/8	(238.13)	9 1/4	(234.95)
633	B	--	--	--	--	--	--	--	--	--	--	11 3/4	(298.45)	11 1/4	(285.75)

Fig. Number	Type Size	Rod Take-out for Width of Beam Flange with Max. Rod Size C													
		10 (254.0)		11 (279.4)		12 (304.8)		13 (330.2)		14 (355.6)		15 (381.0)		16 (406.4)	
632	A	--	--	--	--	--	--	--	--	--	--	--	--	--	--
632	B	6	(152.40)	5 7/8	(149.23)	--	--	--	--	--	--	--	--	--	--
633	A	9 1/8	(231.78)	8 7/8	(225.43)	8 1/2	(215.90)	8 1/8	(206.38)	7 3/4	(196.85)	7 1/8	(180.98)	--	--
633	B	11	(279.40)	10 7/8	(276.23)	10 3/4	(273.05)	10 5/8	(269.88)	10 1/4	(260.35)	9 7/8	(250.83)	9 3/8	(238.13)

Unless otherwise specified, all dimensions on drawings and in charts are in inches and dimensions shown in parentheses are in millimeters.

# CENTER LOAD BEAM CLAMPS



## ADJUSTABLE STEEL BEAM CLAMP FIG. 635

- Function:** Designed to be used in the suspension of a hanger rod from an I-Beam. The clamp is adjustable from 3½” (88.9) to 8” (203.2) and can be used with flange thicknesses up to 1½” (12.7).
- Material:** Carbon steel (Type 304 or 316 Stainless Steel upon request)
- Finish:** Plain or electro-galvanized (Hot dipped galvanized with electro-galvanized hardware upon request)
- Approvals:** Complies with Federal Specification A-A-1192A (Type 27) and Manufacturers’ Standardization Society ANSI/MSS SP-58 (Type 27) which supersedes ANSI/MSS SP-69.
- Ordering:** Specify figure number, rod size, material, and finish.

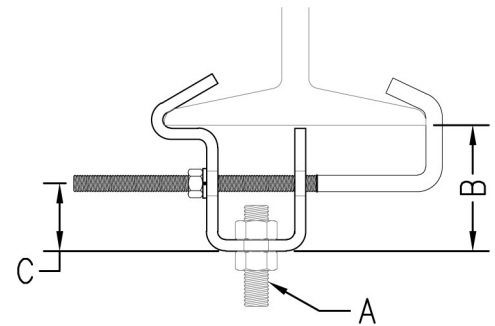

*NOTE: For proper installation, tighten hex nut until lock washer is completely flat.*

Rod Size A	Flange Width				B		C		Max. Rec. Load		Wt. Each	
	Min.		Max.						lbs.	kN	lbs.	kg
3/8	3 1/2	(88.90)	8	(203.20)	2 3/4	(69.85)	1 1/2	(38.10)	300	(1.33)	1.04	(.47)
1/2	3 1/2	(88.90)	8	(203.20)	2 3/4	(69.85)	1 1/2	(38.10)	700	(3.11)	1.45	(.66)
5/8	3 1/2	(88.90)	8	(203.20)	2 3/4	(69.85)	1 1/2	(38.10)	1000	(4.45)	1.96	(.89)
3/4	6	(152.40)	8	(203.20)	4	(101.60)	2	(50.80)	1800	(8.01)	6.50	(2.95)

Unless otherwise specified, all dimensions on drawings and in charts are in inches and dimensions shown in parentheses are in millimeters.

- THREADED ACCESSORIES
- CPVC STRAPS
- BAND HANGERS
- BEAM CLAMPS
- CLEVIS HANGERS
- PIPE ROLLER SUPPORTS
- PIPE RING HANGERS
- PIPE CLAMPS
- CENTER LOAD BEAM CLAMPS
- PIPE SHIELDS, INSULATION, & SADDLES
- PIPE GUIDES & SLIDES
- WALL BRACKETS
- PIPE SUPPORTS
- STRUCTURAL ATTACHMENTS
- SEISMIC BRACING

**FIG. 160**

## SELF CENTERING INSULATION SHIELD

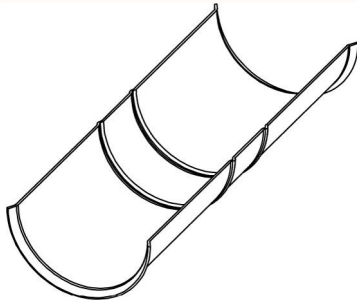

**Function:** Designed to provide maximum protection to the insulation. The centering ribs are spaced to center the hanger on the shield, providing equal load distribution. The shield is furnished with flared ends to prevent it from cutting into the insulation.

**Material:** Carbon steel (Type 304 or 316 Stainless Steel upon request)

**Finish:** Pre-galvanized

**Ordering:** Specify figure number, shield number, and material.

**NOTE:** To determine proper size consult shield selection guide.

Size No.	Shield I.D.		Shield Length		Shield Gauge	Hanger Size		Rib Spacing		Wt. Each	
		(mm)		(mm)			(mm)		(mm)	lbs.	kg
1	2 <sup>3</sup> / <sub>8</sub>	(60.33)	8	(203.20)	18	2	(50)	1 <sup>1</sup> / <sub>4</sub>	(31.75)	.35	(.16)
2	2 <sup>5</sup> / <sub>8</sub>	(66.68)	8	(203.20)	18	2 <sup>1</sup> / <sub>2</sub>	(65)	1 <sup>1</sup> / <sub>4</sub>	(31.75)	.37	(.17)
3	2 <sup>7</sup> / <sub>8</sub>	(73.03)	8	(203.20)	18	2 <sup>1</sup> / <sub>2</sub>	(65)	1 <sup>1</sup> / <sub>4</sub>	(31.75)	.42	(.19)
4	3 <sup>1</sup> / <sub>2</sub>	(88.90)	8	(203.20)	18	3	(80)	1 <sup>1</sup> / <sub>4</sub>	(31.75)	.56	(.25)
5	4	(101.60)	8	(203.20)	18	3 <sup>1</sup> / <sub>2</sub>	(90)	1 <sup>1</sup> / <sub>4</sub>	(31.75)	.63	(.29)
6	4 <sup>1</sup> / <sub>2</sub>	(114.30)	8	(203.20)	18	4	(100)	1 <sup>1</sup> / <sub>4</sub>	(31.75)	.72	(.33)
7	5	(127.00)	8	(203.20)	18	5	(125)	1 <sup>1</sup> / <sub>4</sub>	(31.75)	.82	(.37)
8	5 <sup>5</sup> / <sub>8</sub>	(142.88)	8	(203.20)	18	5	(125)	1 <sup>1</sup> / <sub>4</sub>	(31.75)	.92	(.42)
9	6	(152.40)	8	(203.20)	18	6	(150)	2	(50.80)	.98	(.44)
10	6 <sup>5</sup> / <sub>8</sub>	(168.28)	8	(203.20)	18	6	(150)	2	(50.80)	1.08	(.49)
11	7 <sup>5</sup> / <sub>8</sub>	(193.68)	12	(304.80)	18	8	(200)	2	(50.80)	2.16	(.98)
12	8 <sup>5</sup> / <sub>8</sub>	(219.08)	12	(304.80)	18	8	(200)	2	(50.80)	2.43	(1.10)
13	9 <sup>5</sup> / <sub>8</sub>	(244.48)	12	(304.80)	18	10	(250)	2	(50.80)	2.73	(1.24)
14	10 <sup>3</sup> / <sub>4</sub>	(273.05)	12	(304.80)	18	10	(250)	2	(50.80)	3.06	(1.39)
15	11 <sup>3</sup> / <sub>4</sub>	(298.45)	12	(304.80)	18	12	(300)	2 <sup>1</sup> / <sub>4</sub>	(57.15)	3.34	(1.51)
16	12 <sup>3</sup> / <sub>4</sub>	(323.85)	12	(304.80)	18	12	(300)	2 <sup>1</sup> / <sub>4</sub>	(57.15)	3.60	(1.63)
17	14	(355.60)	12	(304.80)	18	14	(350)	2 <sup>1</sup> / <sub>4</sub>	(57.15)	3.96	(1.80)
18	15	(381.00)	12	(304.80)	18	16	(400)	2 <sup>3</sup> / <sub>4</sub>	(69.85)	4.23	(1.92)
19	16	(406.40)	12	(304.80)	18	16	(400)	2 <sup>3</sup> / <sub>4</sub>	(69.85)	2.35	(1.07)
20	17	(431.80)	12	(304.80)	18	18	(450)	2 <sup>3</sup> / <sub>4</sub>	(69.85)	2.80	(1.27)
21	18	(457.20)	12	(304.80)	18	18	(450)	2 <sup>3</sup> / <sub>4</sub>	(69.85)	5.08	(2.30)
22	19	(482.60)	12	(304.80)	18	20	(500)	3 <sup>1</sup> / <sub>4</sub>	(82.55)	5.36	(2.43)
23	20	(508.00)	12	(304.80)	18	20	(500)	3 <sup>1</sup> / <sub>4</sub>	(82.55)	5.56	(2.52)
24	21	(533.40)	12	(304.80)	18	24	(600)	3 <sup>1</sup> / <sub>4</sub>	(82.55)	5.90	(2.68)

# INSULATION SHIELDS



## INSULATION PROTECTION SHIELD

**FIG. 170**

- Function:** Designed for use in the suspension of insulated pipe lines to protect the insulation from being crushed by the hanger.
- Material:** Carbon steel (Type 304 or 316 Stainless Steel upon request)
- Finish:** Pre-galvanized
- Approvals:** Complies with Federal Specifications A-A-1192A (Type 40) and Manufacturers' Standardization Society ANSI/MSS SP-58 (Type 40) which supersedes ANSI/MSS SP-69.
- Ordering:** Specify figure number, shield number, and material.

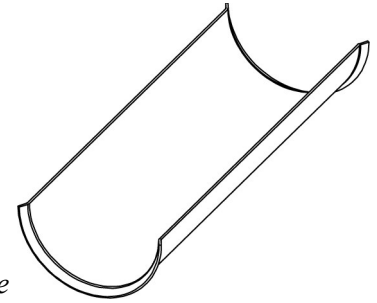

*NOTE: 12" (304.8mm) length shields furnished with flared ends. To determine proper size consult shield selection guide.*

Size No.	Shield I.D.		Shield Length		Shield Gauge	Hanger Size		Wt. Each	
		(mm)		(mm)			(mm)	lbs.	kg
1A	2 <sup>3</sup> / <sub>8</sub>	(60.33)	12	(304.8)	18	2	(50)	.55	(.25)
2A	2 <sup>5</sup> / <sub>8</sub>	(66.68)	12	(304.8)	18	2 <sup>1</sup> / <sub>2</sub>	(65)	.64	(.29)
3A	2 <sup>7</sup> / <sub>8</sub>	(73.03)	12	(304.8)	18	2 <sup>1</sup> / <sub>2</sub>	(65)	.66	(.30)
4A	3 <sup>1</sup> / <sub>2</sub>	(88.90)	12	(304.8)	18	3	(80)	.89	(.40)
5A	4	(101.60)	12	(304.8)	18	3 <sup>1</sup> / <sub>2</sub>	(90)	.91	(.41)
6A	4 <sup>1</sup> / <sub>2</sub>	(114.30)	12	(304.8)	18	4	(100)	1.12	(.51)
7A	5	(127.00)	12	(304.8)	18	5	(125)	1.15	(.52)
8A	5 <sup>5</sup> / <sub>8</sub>	(142.88)	12	(304.8)	18	5	(125)	1.35	(.61)
8B	5 <sup>5</sup> / <sub>8</sub>	(142.88)	12	(304.8)	16	5	(125)	2.00	(.91)
9A	6	(152.40)	12	(304.8)	18	6	(150)	1.45	(.66)
9B	6	(152.40)	12	(304.8)	16	6	(150)	2.10	(.95)
10A	6 <sup>5</sup> / <sub>8</sub>	(168.28)	12	(304.8)	18	6	(150)	1.50	(.68)
10B	6 <sup>5</sup> / <sub>8</sub>	(168.28)	12	(304.8)	16	6	(150)	2.37	(1.08)
11A	7 <sup>5</sup> / <sub>8</sub>	(193.68)	12	(304.8)	18	8	(200)	2.02	(.92)
11B	7 <sup>5</sup> / <sub>8</sub>	(193.68)	12	(304.8)	16	8	(200)	2.50	(1.13)
11C	7 <sup>5</sup> / <sub>8</sub>	(193.68)	18	(457.2)	16	8	(200)	3.75	(1.70)
12A	8 <sup>5</sup> / <sub>8</sub>	(219.08)	12	(304.8)	18	8	(200)	2.28	(1.03)
12B	8 <sup>5</sup> / <sub>8</sub>	(219.08)	12	(304.8)	16	8	(200)	2.83	(1.28)
12C	8 <sup>5</sup> / <sub>8</sub>	(219.08)	18	(457.2)	16	8	(200)	4.25	(1.93)
13A	9 <sup>5</sup> / <sub>8</sub>	(244.48)	12	(304.8)	18	10	(250)	2.54	(1.15)
13B	9 <sup>5</sup> / <sub>8</sub>	(244.48)	12	(304.8)	16	10	(250)	3.15	(1.43)
13C	9 <sup>5</sup> / <sub>8</sub>	(244.48)	18	(457.2)	16	10	(250)	4.73	(2.15)
14A	10 <sup>3</sup> / <sub>4</sub>	(273.05)	12	(304.8)	18	10	(250)	2.84	(1.29)
14B	10 <sup>3</sup> / <sub>4</sub>	(273.05)	12	(304.8)	16	10	(250)	3.53	(1.60)
14C	10 <sup>3</sup> / <sub>4</sub>	(273.05)	18	(457.2)	16	10	(250)	5.30	(2.40)
14D	10 <sup>3</sup> / <sub>4</sub>	(273.05)	24	(609.6)	14	10	(250)	9.63	(4.37)
15B	11 <sup>3</sup> / <sub>4</sub>	(298.45)	12	(304.8)	16	12	(300)	4.00	(1.81)
15C	11 <sup>3</sup> / <sub>4</sub>	(298.45)	18	(457.2)	16	12	(300)	6.00	(2.72)
15D	11 <sup>3</sup> / <sub>4</sub>	(298.45)	24	(609.6)	14	12	(300)	10.00	(4.54)
16B	12 <sup>3</sup> / <sub>4</sub>	(323.85)	12	(304.8)	16	12	(300)	4.18	(1.90)

Size No.	Shield I.D.		Shield Length		Shield Gauge	Hanger Size		Wt. Each	
		(mm)		(mm)			(mm)	lbs.	kg
16C	12 <sup>3</sup> / <sub>4</sub>	(323.85)	18	(457.2)	16	12	(300)	6.28	(2.85)
16D	12 <sup>3</sup> / <sub>4</sub>	(323.85)	24	(609.6)	14	12	(300)	10.90	(4.94)
17B	14	(355.60)	12	(304.8)	16	14	(350)	4.58	(2.08)
17D	14	(355.60)	24	(609.6)	14	14	(350)	12.25	(5.56)
18B	15	(381.00)	12	(304.8)	16	16	(400)	4.90	(2.22)
18D	15	(381.00)	24	(609.6)	14	16	(400)	13.00	(5.90)
19B	16	(406.40)	12	(304.8)	16	16	(400)	5.20	(2.36)
19D	16	(406.40)	24	(609.6)	14	16	(400)	13.81	(6.26)
20B	17	(431.80)	12	(304.8)	16	18	(450)	5.53	(2.51)
20D	17	(431.80)	24	(609.6)	14	18	(450)	14.56	(6.60)
21B	18	(457.20)	12	(304.8)	16	18	(450)	6.20	(2.81)
21D	18	(457.20)	24	(609.6)	14	18	(450)	15.46	(7.01)
21E	18	(457.20)	24	(609.6)	12	18	(450)	21.25	(9.64)
22B	19	(482.60)	12	(304.8)	16	20	(500)	6.50	(2.95)
22D	19	(482.60)	24	(609.6)	14	20	(500)	16.32	(7.40)
22E	19	(482.60)	24	(609.6)	12	20	(500)	22.41	(10.17)
23B	20	(508.00)	12	(304.8)	16	20	(500)	7.25	(3.29)
23D	20	(508.00)	24	(609.6)	14	20	(500)	17.18	(7.79)
23E	20	(508.00)	24	(609.6)	12	20	(500)	24.75	(11.23)
24B	21	(533.40)	12	(304.8)	16	24	(600)	7.30	(3.31)
24E	21	(533.40)	24	(609.6)	12	24	(600)	24.75	(11.23)
25B	22	(558.80)	12	(304.8)	16	24	(600)	7.60	(3.45)
25E	22	(558.80)	24	(609.6)	12	24	(600)	25.92	(11.76)
26B	23	(584.20)	12	(304.8)	16	24	(600)	7.75	(3.52)
26E	23	(584.20)	24	(609.6)	12	24	(600)	26.50	(12.02)
27B	24	(609.60)	12	(304.8)	16	24	(600)	8.00	(3.63)
27E	24	(609.60)	24	(609.6)	12	24	(600)	27.20	(12.34)
28E	26	(660.40)	24	(609.6)	12	30	(750)	28.00	(12.70)
29E	27	(685.80)	24	(609.6)	12	30	(750)	30.20	(13.70)
30E	28	(711.20)	24	(609.6)	12	30	(750)	32.50	(14.74)

Unless otherwise specified, all dimensions on drawings and in charts are in inches and dimensions shown in parentheses are in millimeters.

THREADED ACCESSORIES  
CPVC STRAPS  
BAND HANGERS  
BEAM CLAMPS  
CLEVIS HANGERS  
PIPE ROLLER SUPPORTS  
SPLIT RING HANGERS  
PIPE CLAMPS  
CENTER LOAD BEAM CLAMPS  
PIPE SHIELDS, INSULATION, & SADDLES  
PIPE GUIDES & SLIDES  
WALL BRACKETS  
PIPE SUPPORTS  
STRUCTURAL ATTACHMENTS  
SEISMIC BRACING

# INSULATION SHIELDS

## FIG. 145, 155, 160, 170, & 455

## SHIELD SELECTION GUIDE

**TO DETERMINE PROPER SHIELD SIZE FOR SIZES NOT LISTED:**

Add 2 times the thickness of the insulation plus the measured O.D. of the pipe. Select shield with I.D. no smaller than the sum total of measured pipe O.D. and twice the insulation.

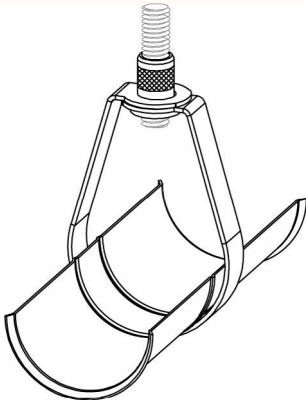

**Fig. 145 & 155**

### SHIELD NUMBER FOR STEEL PIPE

Pipe Size		Pipe O.D.		Insulation Thickness								
				1/2(12.7)	3/4 (19.0)	1 (25.4)	1 1/2 (38.1)	2 (50.8)	2 1/2 (63.5)	3 (76.2)	3 1/2 (88.9)	4 (101.6)
1/2	(15)	.840	(21.34)	1	1	3	5	7	9	11	--	--
3/4	(20)	1.050	(26.67)	1	2	4	5	7	10	11	--	--
1	(25)	1.315	(33.40)	1	3	4	6	8	10	11	12	13
1 1/4	(32)	1.660	(42.16)	3	4	5	7	8	10	11	12	13
1 1/2	(40)	1.900	(48.26)	3	4	5	7	9	11	12	13	14
2	(50)	2.375	(60.33)	4	5	6	8	10	11	12	13	14
2 1/2	(65)	2.875	(73.03)	5	6	7	9	11	12	13	14	15
3	(80)	3.500	(88.90)	6	7	8	10	11	12	13	14	15
3 1/2	(90)	4.000	(101.60)	7	8	9	11	12	13	14	15	16
4	(100)	4.500	(114.30)	8	9	10	11	12	13	14	15	16
5	(125)	5.563	(141.30)	10	11	11	12	13	14	15	16	17
6	(150)	6.625	(168.28)	11	12	12	13	14	15	16	17	18
8	(200)	8.626	(219.10)	13	14	14	15	16	17	18	19	20
10	(250)	10.750	(273.05)	15	16	16	17	18	19	20	21	22
12	(300)	12.750	(323.85)	17	18	18	19	20	21	22	23	24

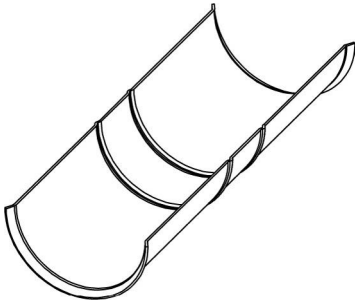

**Fig. 160**

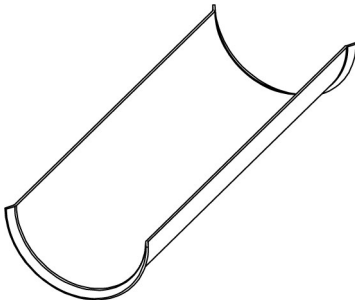

**Fig. 170**

### SHIELD NUMBER FOR COPPER TUBING

Tube Size		Tube O.D.		Insulation Thickness						
				1/2(12.7)	3/4 (19.0)	1 (25.4)	1 1/2 (38.1)	2 (50.8)	2 1/2 (63.5)	3 (76.2)
1/2	(15)	0.625	(15.9)	1	1	2	5	7	8	10
3/4	(20)	0.875	(22.2)	1	1	3	5	7	9	11
1	(25)	1.125	(28.6)	1	2	4	6	8	10	11
1 1/4	(32)	1.375	(34.9)	1	3	4	6	8	10	11
1 1/2	(40)	1.625	(41.3)	2	4	5	7	8	10	11
2	(50)	2.125	(54.0)	4	5	6	8	10	11	12
2 1/2	(65)	2.625	(66.7)	5	6	7	8	10	11	12
3	(80)	3.125	(79.4)	6	7	8	10	11	12	13
3 1/2	(90)	3.625	(92.1)	7	8	8	10	11	12	13
4	(100)	4.125	(104.8)	8	8	10	11	12	13	14
5	(125)	5.125	(130.2)	10	10	11	12	13	14	15
6	(150)	6.125	(155.6)	11	11	12	13	14	15	16

**For Fig. 170**

**Specify Shield Type & Shield Number**

Shield Type	Length		Gauge
A	12	(304.8)	18
B	12	(304.8)	16
C	18	(457.2)	16
D	24	(609.6)	14
E	24	(609.6)	12

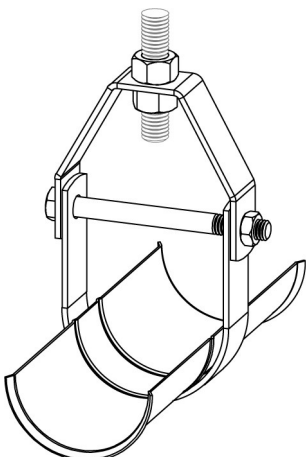

**Fig. 455 & 456**

Unless otherwise specified, all dimensions on drawings and in charts are in inches and dimensions shown in parentheses are in millimeters.

# INSULATION



## SNAPPITZ SELF-LOCKING INSULATION

## FIG. 165 & 166

**Function:** Designed for the insulation of iron pipe (Fig. 165) or copper tube (Fig. 166). The one piece self-locking design allows for easier and faster installation and eliminates the need for a separate shield.

**Material:** PVC plastic shield with polyisocyanurate or phenolic foam insulation.

**Approvals:** ASTM-E84-05 and tested by Intertek. Smoke & flame tested 5-30.

**Ordering:** Specify figure number, pipe or tube size, and insulation thickness.

*NOTE: Other sizes available upon request.*

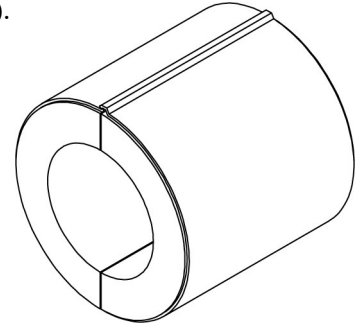

Iron Pipe Size		Insulation Thickness		Length		Wt. Each	
						lbs.	kg
1/2	(15)	1/2	(12.7)	4	(101.6)	0.078	(.04)
1/2	(15)	1	(25.4)	4	(101.6)	0.143	(.06)
1/2	(15)	1 1/2	(38.1)	4	(101.6)	0.200	(.09)
1/2	(15)	2	(50.8)	4	(101.6)	0.263	(.12)
1/2	(15)	2 1/2	(63.5)	4	(101.6)	0.263	(.12)
1/2	(15)	3	(76.2)	4	(101.6)	0.333	(.15)
3/4	(20)	1/2	(12.7)	4	(101.6)	0.097	(.04)
3/4	(20)	1	(25.4)	4	(101.6)	0.143	(.06)
3/4	(20)	1 1/2	(38.1)	4	(101.6)	0.171	(.08)
3/4	(20)	2	(50.8)	4	(101.6)	0.228	(.10)
3/4	(20)	2 1/2	(63.5)	4	(101.6)	0.228	(.10)
3/4	(20)	3	(76.2)	4	(101.6)	0.346	(.16)
1	(25)	1/2	(12.7)	4	(101.6)	0.109	(.05)
1	(25)	1	(25.4)	4	(101.6)	0.149	(.07)
1	(25)	1 1/2	(38.1)	4	(101.6)	0.253	(.11)
1	(25)	2	(50.8)	4	(101.6)	0.211	(.10)
1	(25)	2 1/2	(63.5)	4	(101.6)	0.320	(.15)
1	(25)	3	(76.2)	4	(101.6)	0.320	(.15)
1 1/4	(32)	1/2	(12.7)	4	(101.6)	0.143	(.06)
1 1/4	(32)	1	(25.4)	4	(101.6)	0.149	(.07)
1 1/4	(32)	1 1/2	(38.1)	4	(101.6)	0.292	(.13)
1 1/4	(32)	2	(50.8)	4	(101.6)	0.263	(.12)
1 1/4	(32)	2 1/2	(63.5)	4	(101.6)	0.346	(.16)
1 1/2	(40)	1/2	(12.7)	4	(101.6)	0.143	(.06)
1 1/2	(40)	1	(25.4)	4	(101.6)	0.200	(.09)
1 1/2	(40)	1 1/2	(38.1)	4	(101.6)	0.264	(.12)
1 1/2	(40)	2	(50.8)	4	(101.6)	0.417	(.19)
1 1/2	(40)	2 1/2	(63.5)	4	(101.6)	0.347	(.16)
2	(50)	1/2	(12.7)	4	(101.6)	0.229	(.10)
2	(50)	1	(25.4)	4	(101.6)	0.500	(.23)
2	(50)	1 1/2	(38.1)	4	(101.6)	0.526	(.24)
2	(50)	2	(50.8)	4	(101.6)	0.417	(.19)
2	(50)	2 1/2	(63.5)	4	(101.6)	0.347	(.16)
2 1/2	(65)	1/2	(12.7)	4	(101.6)	0.329	(.15)
2 1/2	(65)	1	(25.4)	4	(101.6)	0.429	(.19)
2 1/2	(65)	1 1/2	(38.1)	4	(101.6)	0.469	(.21)
2 1/2	(65)	2	(50.8)	4	(101.6)	0.600	(.27)
3	(80)	1/2	(12.7)	6	(152.4)	0.750	(.34)
3	(80)	1	(25.4)	6	(152.4)	0.750	(.34)
3	(80)	1 1/2	(38.1)	6	(152.4)	1.250	(.57)
3	(80)	2	(50.8)	6	(152.4)	1.300	(.59)
3 1/2	(90)	1	(25.4)	6	(152.4)	0.417	(.19)
3 1/2	(90)	1 1/2	(38.1)	6	(152.4)	0.417	(.19)
4	(100)	1/2	(12.7)	6	(152.4)	1.250	(.57)
4	(100)	1	(25.4)	6	(152.4)	1.250	(.57)
4	(100)	1 1/2	(38.1)	6	(152.4)	1.364	(.62)
5	(125)	1/2	(12.7)	6	(152.4)	0.416	(.19)
5	(125)	1	(25.4)	6	(152.4)	0.416	(.19)
6	(150)	1/2	(12.7)	6	(152.4)	0.500	(.23)

Copper Tube Size		Insulation Thickness		Length		Wt. Each	
						lbs.	kg
1/2	(15)	1/2	(12.7)	4	(101.6)	0.153	(.07)
1/2	(15)	1	(25.4)	4	(101.6)	0.153	(.07)
1/2	(15)	1 1/2	(38.1)	4	(101.6)	0.273	(.12)
1/2	(15)	2	(50.8)	4	(101.6)	0.293	(.13)
1/2	(15)	2 1/2	(63.5)	4	(101.6)	0.320	(.15)
1/2	(15)	3	(76.2)	4	(101.6)	0.400	(.18)
3/4	(20)	1/2	(12.7)	4	(101.6)	0.143	(.06)
3/4	(20)	1	(25.4)	4	(101.6)	0.153	(.07)
3/4	(20)	1 1/2	(38.1)	4	(101.6)	0.238	(.11)
3/4	(20)	2	(50.8)	4	(101.6)	0.248	(.11)
3/4	(20)	2 1/2	(63.5)	4	(101.6)	0.416	(.19)
3/4	(20)	3	(76.2)	4	(101.6)	0.480	(.22)
1	(25)	1/2	(12.7)	4	(101.6)	0.143	(.06)
1	(25)	1	(25.4)	4	(101.6)	0.153	(.07)
1	(25)	1 1/2	(38.1)	4	(101.6)	0.285	(.13)
1	(25)	2	(50.8)	4	(101.6)	0.295	(.13)
1	(25)	2 1/2	(63.5)	4	(101.6)	0.400	(.18)
1	(25)	3	(76.2)	4	(101.6)	0.480	(.22)
1 1/4	(32)	1/2	(12.7)	4	(101.6)	0.190	(.09)
1 1/4	(32)	1	(25.4)	4	(101.6)	0.208	(.09)
1 1/4	(32)	1 1/2	(38.1)	4	(101.6)	0.300	(.14)
1 1/4	(32)	2	(50.8)	4	(101.6)	0.310	(.14)
1 1/4	(32)	2 1/2	(63.5)	4	(101.6)	0.400	(.18)
1 1/4	(32)	3	(76.2)	4	(101.6)	0.480	(.22)
1 1/2	(40)	1/2	(12.7)	4	(101.6)	0.213	(.10)
1 1/2	(40)	1	(25.4)	4	(101.6)	0.213	(.10)
1 1/2	(40)	1 1/2	(38.1)	4	(101.6)	0.417	(.19)
1 1/2	(40)	2	(50.8)	4	(101.6)	0.420	(.19)
1 1/2	(40)	2 1/2	(63.5)	4	(101.6)	0.400	(.18)
2	(50)	1/2	(12.7)	4	(101.6)	0.286	(.13)
2	(50)	1	(25.4)	4	(101.6)	0.286	(.13)
2	(50)	1 1/2	(38.1)	4	(101.6)	0.417	(.19)
2	(50)	2	(50.8)	4	(101.6)	0.427	(.19)
2	(50)	2 1/2	(63.5)	4	(101.6)	0.300	(.14)
2 1/2	(65)	1/2	(12.7)	4	(101.6)	0.449	(.20)
2 1/2	(65)	1	(25.4)	4	(101.6)	1.100	(.50)
2 1/2	(65)	1 1/2	(38.1)	4	(101.6)	0.469	(.21)
2 1/2	(65)	2	(50.8)	4	(101.6)	0.469	(.21)
2 1/2	(65)	2 1/2	(63.5)	4	(101.6)	0.200	(.09)
3	(80)	1/2	(12.7)	6	(152.4)	0.156	(.07)
3	(80)	1	(25.4)	6	(152.4)	0.313	(.14)
3	(80)	1 1/2	(38.1)	6	(152.4)	0.429	(.19)
3	(80)	2	(50.8)	6	(152.4)	0.416	(.19)
4	(100)	1	(25.4)	6	(152.4)	0.571	(.26)
4	(100)	1 1/2	(38.1)	6	(152.4)	0.682	(.31)

Unless otherwise specified, all dimensions on drawings and in charts are in inches and dimensions shown in parentheses are in millimeters.

THREADED ACCESSORIES  
CPVC STRAPS  
BAND HANGERS  
BEAM CLAMPS  
CLEVIS HANGERS  
PIPE ROLLER SUPPORTS  
PIPE RING HANGERS  
SPLIT RING HANGERS  
PIPE CLAMPS  
PIPE CLAMPS  
CENTER LOAD BEAM CLAMPS  
PIPE SHIELDS, INSULATION, & SADDLES  
PIPE GUIDES & SLIDES  
WALL BRACKETS  
PIPE SUPPORTS  
STRUCTURAL ATTACHMENTS  
SEISMIC BRACING

# INSULATION

## FIG. 167 & 168

## SNAPPITZ NON-LOCKING INSULATION

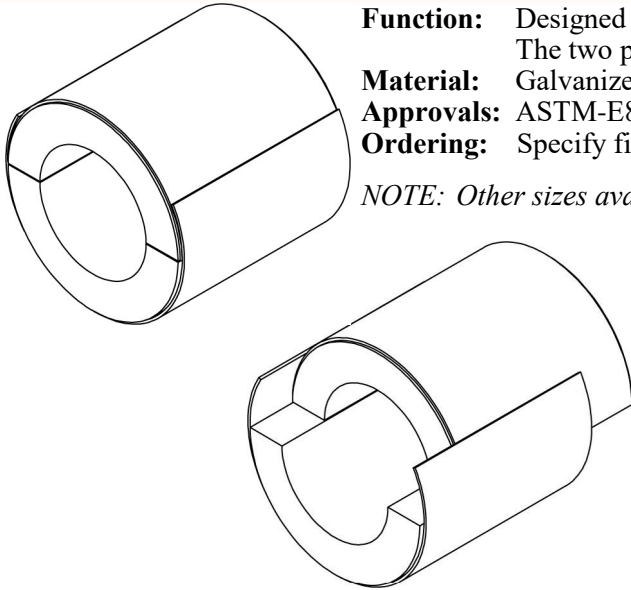

**Function:** Designed for the insulation of iron pipe (**Fig. 167**) or copper tube (**Fig. 168**). The two piece non-locking design eliminates the need for a separate shield.

**Material:** Galvanized metal shield with polyisocyanurate or phenolic foam insulation

**Approvals:** ASTM-E84-05 and tested by Intertek. Smoke & flame tested 5-30.

**Ordering:** Specify figure number, pipe or tube size, and insulation thickness.

*NOTE: Other sizes available upon request.*

Copper Tube Size		Insulation Thickness		Length		Wt. Each	
						lbs.	kg
1 1/2	(40)	3	(76.2)	4	(101.6)	.0958	(.04)
2	(50)	3	(76.2)	4	(101.6)	1.273	(.58)
2 1/2	(65)	3	(76.2)	4	(101.6)	1.364	(.62)
3	(80)	2 1/2	(63.5)	6	(152.4)	1.477	(.67)
3	(80)	3	(76.2)	6	(152.4)	1.477	(.67)
4	(100)	2	(50.8)	6	(152.4)	1.636	(.74)
4	(100)	2 1/2	(63.5)	6	(152.4)	3.125	(1.42)
4	(100)	3	(76.2)	6	(152.4)	3.750	(1.70)

Iron Pipe Size		Insulation Thickness		Length		Wt. Each	
						lbs.	kg
1 1/4	(32)	3	(76.2)	4	(101.6)	0.893	(.41)
1 1/2	(40)	3	(76.2)	4	(101.6)	0.833	(.38)
2	(50)	3	(76.2)	4	(101.6)	0.833	(.38)
2 1/2	(65)	2 1/2	(63.5)	4	(101.6)	1.667	(.76)
2 1/2	(65)	3	(76.2)	6	(152.4)	2.083	(.94)
3	(80)	2 1/2	(63.5)	6	(152.4)	2.500	(1.13)
3	(80)	3	(76.2)	6	(152.4)	1.458	(.66)
3 1/2	(90)	2	(50.8)	6	(152.4)	2.500	(1.13)
3 1/2	(90)	2 1/2	(63.5)	6	(152.4)	3.000	(1.36)
3 1/2	(90)	3	(76.2)	6	(152.4)	2.500	(1.13)
4	(100)	2	(50.8)	6	(152.4)	3.750	(1.70)
4	(100)	2 1/2	(63.5)	6	(152.4)	3.750	(1.70)
4	(100)	3	(76.2)	6	(152.4)	3.750	(1.70)
5	(125)	1 1/2	(25.4)	6	(152.4)	3.125	(1.42)
5	(125)	2	(38.1)	6	(152.4)	3.750	(1.70)
5	(125)	2 1/2	(50.8)	6	(152.4)	3.750	(1.70)
5	(125)	3	(63.5)	6	(152.4)	4.688	(2.13)
6	(150)	1	(25.4)	6	(152.4)	2.500	(1.13)
6	(150)	1 1/2	(38.1)	6	(152.4)	2.750	(1.25)
6	(150)	2	(50.8)	6	(152.4)	4.000	(1.81)
6	(150)	2 1/2	(63.5)	6	(152.4)	6.250	(2.83)
6	(150)	3	(76.2)	6	(152.4)	9.375	(4.25)
8	(200)	1	(25.4)	9	(228.6)	3.000	(1.36)
8	(200)	1 1/2	(38.1)	9	(228.6)	3.000	(1.36)
8	(200)	2	(50.8)	9	(228.6)	4.000	(1.81)
8	(200)	2 1/2	(63.5)	9	(228.6)	7.500	(3.40)
8	(200)	3	(76.2)	9	(228.6)	7.500	(3.40)
10	(250)	1	(25.4)	9	(228.6)	4.000	(1.81)
10	(250)	1 1/2	(38.1)	9	(228.6)	4.000	(1.81)
10	(250)	2	(50.8)	9	(228.6)	4.000	(1.81)
10	(250)	2 1/2	(63.5)	12	(304.8)	8.000	(3.63)
10	(250)	3	(76.2)	12	(304.8)	8.000	(3.63)
12	(300)	1	(25.4)	12	(304.8)	8.000	(3.63)
12	(300)	1 1/2	(38.1)	12	(304.8)	8.000	(3.63)
12	(300)	2	(50.8)	12	(304.8)	8.000	(3.63)
12	(300)	2 1/2	(63.5)	12	(304.8)	8.000	(3.63)
12	(300)	3	(76.2)	12	(304.8)	8.000	(3.63)
14	(350)	1	(25.4)	12	(304.8)	10.00	(4.54)
14	(350)	1 1/2	(38.1)	12	(304.8)	10.00	(4.54)
14	(350)	2	(50.8)	12	(304.8)	10.00	(4.54)
14	(350)	2 1/2	(63.5)	12	(304.8)	10.00	(4.54)
14	(350)	3	(76.2)	12	(304.8)	10.00	(4.54)
16	(400)	1	(25.4)	18	(457.2)	20.00	(9.07)
16	(400)	1 1/2	(38.1)	18	(457.2)	20.00	(9.07)
16	(400)	2	(50.8)	18	(457.2)	20.00	(9.07)
16	(400)	2 1/2	(63.5)	18	(457.2)	20.00	(9.07)
16	(400)	3	(76.2)	18	(457.2)	20.00	(9.07)

Unless otherwise specified, all dimensions on drawings and in charts are in inches and dimensions shown in parentheses are in millimeters.



# PIPE COVERING PROTECTION SADDLES



## PIPE SADDLE FOR 1" & 1 1/2" INSULATION FIG. 651 & 653

**Function:** Designed to protect insulation on high temperature pipe lines. The saddle is furnished with notches to minimize surface contact with the pipe, thereby keeping heat loss to a minimum.

**Material:** Carbon steel (Type 304 or 316 Stainless Steel upon request)

**Finish:** Plain or electro-galvanized (Hot dipped galvanized upon request)

**Approvals:** Complies with Federal Specification A-A-1192A (Type 39) and Manufacturers' Standardization Society ANSI/MSS SP-58 (Type 39) which supersedes ANSI/MSS SP-69.

**Ordering:** Specify figure number, pipe size, insulation thickness, material, and finish.

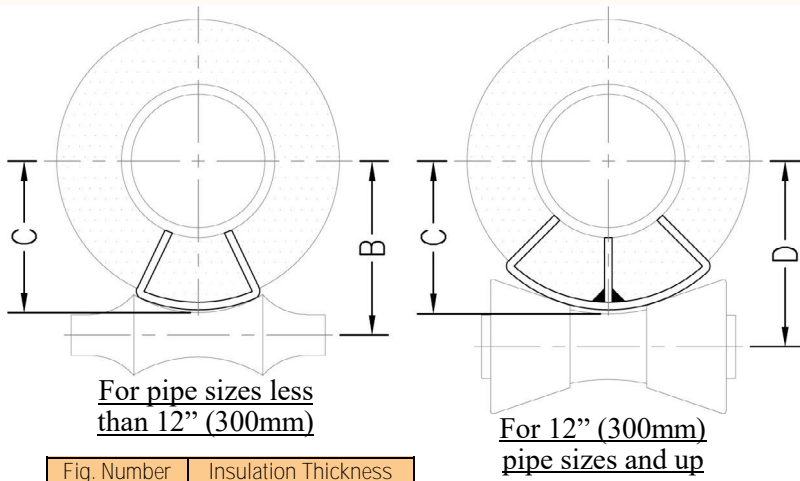

Fig. Number	Insulation Thickness	
651	1	(25.4)
653	1 1/2	(38.1)

Fig. Number	Pipe Size	Pipe Roller Size Use With Fig. No.			Fig. 460, 480, 490 B	Fig. 470, 475 B	C	Fig. 486, 487 D	Actual Thickness Of Covering	Max. Rec. Load		Wt. Each	
		460, 480, 490	470, 475	486, 487						lbs.	kN	lbs.	kg
651	3/4 (20)	2	2 1/2	2-3 1/2	2 1/16 (52.39)	2 1/8 (53.98)	1 5/8 (41.28)	2 1/4 (57.15)	1 5/16 (23.81)	1200 (5.34)	1.41 (.64)		
651	1 (25)	2 1/2	3	2-3 1/2	2 5/16 (58.74)	2 1/4 (57.15)	1 13/16 (46.04)	2 1/16 (61.91)	1 1/16 (26.99)	1200 (5.34)	1.41 (.64)		
651	1 1/4 (32)	2 1/2	3	2-3 1/2	2 1/2 (63.50)	2 7/16 (61.91)	1 15/16 (49.21)	2 9/16 (65.09)	1 5/16 (23.81)	1200 (5.34)	1.41 (.64)		
651	1 1/2 (40)	3	3 1/2	2-3 1/2	2 5/8 (66.68)	2 5/8 (66.68)	2 1/8 (53.98)	2 11/16 (68.26)	1 1/16 (26.99)	1200 (5.34)	1.43 (.65)		
651	2 (50)	3 1/2	4	2-3 1/2	3 (76.20)	2 15/16 (74.61)	2 3/8 (60.33)	3 1/16 (77.79)	1 1/16 (26.99)	1200 (5.34)	1.52 (.69)		
651	2 1/2 (65)	3 1/2	5	2-3 1/2	3 1/4 (82.55)	3 1/4 (82.55)	2 11/16 (68.26)	3 5/16 (84.14)	1 1/16 (26.99)	1200 (5.34)	1.52 (.69)		
651	3 (80)	4	5	2-3 1/2	3 1/2 (88.90)	3 1/2 (88.90)	2 15/16 (74.61)	3 9/16 (90.49)	1 1/16 (26.99)	1200 (5.34)	1.63 (.74)		
651	3 1/2 (90)	5	6	4-6	4 (101.60)	4 (101.60)	3 3/16 (84.14)	3 15/16 (100.01)	1 5/16 (33.34)	1200 (5.34)	1.98 (.90)		
651	4 (100)	5	6	4-6	4 1/4 (107.95)	4 1/4 (107.95)	3 9/16 (90.49)	4 3/16 (106.36)	1 1/16 (26.99)	1800 (8.01)	1.98 (.90)		
651	5 (125)	6	8	4-6	4 13/16 (122.24)	4 13/16 (122.24)	4 1/8 (104.78)	4 3/4 (120.65)	1 1/16 (26.99)	1800 (8.01)	1.98 (.90)		
651	6 (150)	8	8	4-6	5 3/8 (136.53)	5 3/8 (161.93)	4 1/2 (114.30)	5 1/4 (133.35)	1 (25.40)	1800 (8.01)	3.91 (1.64)		
651	8 (200)	10	12	8-10	7 1/16 (179.39)	7 1/16 (179.39)	6 (152.40)	7 1/16 (179.39)	1 1/16 (26.99)	1800 (8.01)	4.75 (2.15)		
651	10 (250)	12	14	8-10	8 5/16 (211.14)	8 1/2 (215.90)	7 1/4 (184.15)	8 5/16 (211.14)	1 (25.40)	1800 (8.01)	4.75 (2.15)		
651	12 (300)	14	16	12-14	8 15/16 (227.01)	8 7/8 (225.43)	7 5/8 (193.68)	8 13/16 (223.84)	1 1/8 (28.58)	5000 (22.24)	6.88 (3.12)		
651	14 (350)	16	18	12-14	9 5/8 (244.48)	9 5/8 (244.48)	8 1/4 (209.55)	9 1/2 (241.30)	1 (25.40)	5000 (22.24)	6.88 (3.12)		
653	3/4 (20)	3	3 1/2	2-3 1/2	2 3/4 (69.85)	2 3/4 (69.85)	2 3/16 (55.56)	2 7/8 (73.03)	1 1/2 (38.10)	1200 (5.34)	1.85 (.84)		
653	1 (25)	3	4	2-3 1/2	2 7/8 (73.03)	2 7/8 (73.03)	2 5/16 (58.74)	3 (76.20)	1 9/16 (39.69)	1200 (5.34)	1.85 (.84)		
653	1 1/4 (32)	3 1/2	5	2-3 1/2	3 1/16 (77.79)	3 1/16 (77.79)	2 9/16 (65.09)	3 3/16 (80.96)	1 11/16 (42.86)	1200 (5.34)	1.85 (.84)		
653	1 1/2 (40)	3 1/2	5	2-3 1/2	3 1/4 (82.55)	3 1/4 (82.55)	2 5/8 (66.68)	3 5/16 (84.14)	1 9/16 (39.69)	1200 (5.34)	1.85 (.84)		
653	2 (50)	4	5	2-3 1/2	3 1/2 (88.90)	3 1/2 (88.90)	2 7/8 (73.03)	3 9/16 (90.49)	1 5/8 (41.28)	1200 (5.34)	1.98 (.90)		
653	2 1/2 (65)	5	6	4-6	4 (101.60)	4 (101.60)	3 5/16 (84.14)	3 15/16 (100.01)	1 7/8 (47.63)	1200 (5.34)	2.25 (1.02)		
653	3 (80)	5	6	4-6	4 5/16 (109.54)	4 5/16 (109.54)	3 5/8 (92.08)	4 1/4 (107.95)	1 9/16 (39.69)	1200 (5.34)	2.25 (1.02)		
653	3 1/2 (90)	6	8	4-6	4 9/16 (115.89)	4 9/16 (115.89)	3 11/16 (93.66)	4 1/2 (114.30)	1 13/16 (46.04)	1200 (5.34)	2.50 (1.13)		
653	4 (100)	6	8	4-6	4 7/8 (123.83)	4 7/8 (123.83)	4 1/16 (103.19)	4 3/4 (120.65)	1 9/16 (39.69)	1800 (8.01)	2.50 (1.13)		
653	5 (125)	8	8	4-6	5 1/2 (139.70)	5 1/2 (139.70)	4 1/16 (119.06)	5 3/8 (136.53)	1 9/16 (39.69)	1800 (8.01)	2.50 (1.13)		
653	6 (150)	8	10	8-10	5 7/8 (149.23)	5 11/16 (144.46)	5 1/16 (128.59)	6 (152.40)	1 1/2 (38.10)	1800 (8.01)	4.25 (1.93)		
653	8 (200)	10	12	8-10	7 1/16 (179.39)	7 1/16 (179.39)	6 (152.40)	7 1/16 (179.39)	1 9/16 (39.69)	1800 (8.01)	5.50 (2.49)		
653	10 (250)	12	14	8-10	8 5/16 (211.14)	8 1/2 (215.90)	7 1/4 (184.15)	8 5/16 (211.14)	1 5/8 (41.28)	1800 (8.01)	5.50 (2.49)		
653	12 (300)	14	16	12-14	9 1/2 (241.30)	9 1/2 (241.30)	8 1/16 (204.79)	9 1/4 (234.95)	1 5/8 (41.28)	5000 (22.24)	8.33 (3.78)		
653	14 (350)	16	18	12-14	10 3/16 (258.76)	10 1/8 (257.18)	8 3/4 (222.25)	10 1/16 (255.59)	1 1/2 (38.10)	5000 (22.24)	8.33 (3.78)		
653	16 (400)	18	20	16-20	11 1/4 (285.75)	11 1/4 (285.75)	9 3/16 (249.24)	11 1/8 (282.58)	1 1/2 (38.10)	5000 (22.24)	9.01 (4.09)		
653	18 (450)	20	24	16-20	12 5/16 (312.74)	--	10 13/16 (274.64)	12 3/16 (309.56)	1 1/2 (38.10)	5000 (22.24)	9.68 (4.39)		
653	20 (500)	24	24	24	13 9/16 (344.49)	--	11 5/8 (295.28)	13 1/16 (331.79)	1 1/2 (38.10)	7200 (32.03)	11.00 (4.99)		
653	24 (600)	30	--	30	16 9/16 (414.34)	--	13 1/2 (342.90)	15 1/4 (387.35)	1 1/2 (38.10)	7200 (32.03)	13.00 (5.90)		
653	30 (750)	--	--	36-42	--	--	16 11/16 (423.86)	18 5/16 (465.14)	1 1/2 (38.10)	7200 (32.03)	13.70 (6.21)		
653	36 (900)	--	--	36-42	--	--	19 11/16 (500.06)	21 7/16 (544.51)	1 1/2 (38.10)	7200 (32.03)	15.74 (7.14)		

Maximum recommended loads are applicable only when the saddle is used on a flat bearing surface and tack welded to the pipe. When a saddle is used with a pipe roll, the maximum load given for the pipe roll applies to the saddle.

Unless otherwise specified, all dimensions on drawings and in charts are in inches and dimensions shown in parentheses are in millimeters.

THREADED ACCESSORIES  
 CPVC STRAPS  
 BAND HANGERS  
 BEAM CLAMPS  
 CLEVIS HANGERS  
 PIPE ROLLER SUPPORTS  
 RING HANGERS  
 SPLIT RING HANGERS  
 PIPE CLAMPS  
 CENTER LOAD BEAM CLAMPS  
 PIPE SHIELDS, INSULATION, & SADDLES  
 PIPE GUIDES & SLIDES  
 WALL BRACKETS  
 PIPE SUPPORTS  
 STRUCTURAL ATTACHMENTS  
 SEISMIC BRACING



# PIPE COVERING PROTECTION SADDLES



## PIPE SADDLE FOR 3” & 4” INSULATION

## FIG. 656 & 658

**Function:** Designed to protect insulation on high temperature pipe lines. The saddle is furnished with notches to minimize surface contact with the pipe, thereby keeping heat loss to a minimum.

**Material:** Carbon steel (Type 304 or 316 Stainless Steel upon request)

**Finish:** Plain or electro-galvanized (Hot dipped galvanized upon request)

**Approvals:** Complies with Federal Specification A-A-1192A (Type 39) and Manufacturers' Standardization Society ANSI/MSS SP-58 (Type 39) which supersedes ANSI/MSS SP-69.

**Ordering:** Specify figure number, pipe size, insulation thickness, material, and finish.

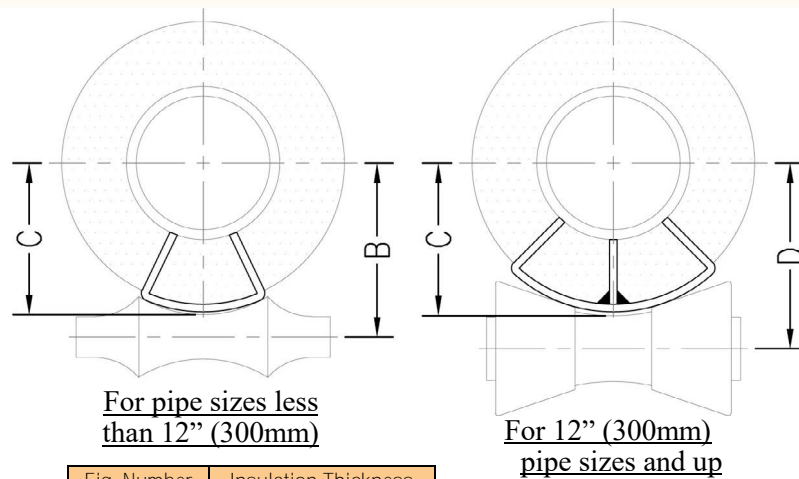

Fig. Number	Insulation Thickness	
656	3	(76.2)
658	4	(101.6)

Fig. Number	Pipe Size		Pipe Roller Size			Fig. 460, 480, 490 B	Fig. 470, 475, 487 B	C		Fig. 486, 487 D	Actual Thickness Of Covering	Max. Rec. Load		Wt. Each	
			Use With Fig. No.					lbs.	kN			lbs.	kg		
			460, 480, 490	470, 475, 487	486, 487										
656	2	(50)	8	8	4-6	5 <sup>3</sup> / <sub>8</sub> (136.53)	5 <sup>3</sup> / <sub>8</sub> (136.53)	4 <sup>9</sup> / <sub>16</sub> (115.89)	5 <sup>1</sup> / <sub>4</sub> (133.35)	3 <sup>1</sup> / <sub>8</sub> (79.38)	1800 (8.01)	4.10 (1.86)			
656	2½	(65)	8	10	4-6	5 <sup>5</sup> / <sub>8</sub> (142.88)	5 <sup>3</sup> / <sub>4</sub> (146.05)	4 <sup>7</sup> / <sub>8</sub> (123.83)	5½ (139.70)	3 <sup>3</sup> / <sub>8</sub> (85.73)	1800 (8.01)	4.10 (1.86)			
656	3	(80)	8	10	8-10	6 (152.40)	6 (152.40)	5 <sup>1</sup> / <sub>16</sub> (128.59)	6 <sup>1</sup> / <sub>16</sub> (153.99)	3 <sup>1</sup> / <sub>16</sub> (77.79)	1800 (8.01)	4.32 (1.96)			
656	3½	(90)	10	10	8-10	6 <sup>5</sup> / <sub>16</sub> (160.34)	6 <sup>5</sup> / <sub>16</sub> (160.34)	5 <sup>3</sup> / <sub>8</sub> (136.53)	6 <sup>3</sup> / <sub>8</sub> (161.93)	3 <sup>3</sup> / <sub>8</sub> (85.73)	1800 (8.01)	4.32 (1.96)			
656	4	(100)	10	10	8-10	6 <sup>9</sup> / <sub>16</sub> (166.69)	6 <sup>9</sup> / <sub>16</sub> (166.69)	5 <sup>5</sup> / <sub>8</sub> (142.88)	6 <sup>5</sup> / <sub>8</sub> (168.28)	3 <sup>1</sup> / <sub>8</sub> (79.38)	1800 (8.01)	4.32 (1.96)			
656	5	(125)	10	12	8-10	7 <sup>1</sup> / <sub>8</sub> (180.98)	7 <sup>1</sup> / <sub>4</sub> (184.15)	6 <sup>3</sup> / <sub>16</sub> (157.16)	7 <sup>1</sup> / <sub>4</sub> (184.15)	3 <sup>1</sup> / <sub>8</sub> (79.38)	1800 (8.01)	4.32 (1.96)			
656	6	(150)	12	12	8-10	7 <sup>5</sup> / <sub>8</sub> (193.68)	7 <sup>5</sup> / <sub>8</sub> (193.68)	6 <sup>9</sup> / <sub>16</sub> (166.69)	7 <sup>5</sup> / <sub>8</sub> (193.68)	3 <sup>1</sup> / <sub>16</sub> (77.79)	1800 (8.01)	8.10 (3.67)			
656	8	(200)	14	16	12-14	9 (228.60)	9 (228.60)	7 <sup>1</sup> / <sub>16</sub> (195.26)	8 <sup>3</sup> / <sub>4</sub> (222.25)	3 <sup>3</sup> / <sub>16</sub> (80.96)	1800 (8.01)	8.10 (3.67)			
656	10	(250)	16	18	16-20	10 <sup>1</sup> / <sub>8</sub> (257.18)	10 <sup>1</sup> / <sub>16</sub> (255.59)	8 <sup>1</sup> / <sub>16</sub> (220.66)	10 (254.00)	3 <sup>1</sup> / <sub>8</sub> (79.38)	1800 (8.01)	8.40 (3.81)			
656	12	(300)	18	20	16-20	11 <sup>1</sup> / <sub>8</sub> (282.58)	11 <sup>1</sup> / <sub>4</sub> (285.75)	9 <sup>5</sup> / <sub>8</sub> (244.48)	11 (279.40)	3 <sup>1</sup> / <sub>8</sub> (79.38)	5000 (22.24)	11.88 (5.39)			
656	14	(350)	18	20	16-20	11 <sup>3</sup> / <sub>4</sub> (298.45)	11 <sup>3</sup> / <sub>4</sub> (298.45)	10 <sup>5</sup> / <sub>16</sub> (261.94)	11 <sup>5</sup> / <sub>8</sub> (295.28)	3 (76.20)	5000 (22.24)	11.88 (5.39)			
656	16	(400)	20	24	24	12 <sup>7</sup> / <sub>8</sub> (327.03)	-- --	11 <sup>1</sup> / <sub>16</sub> (280.99)	12 <sup>7</sup> / <sub>16</sub> (315.91)	3 (76.20)	7200 (32.03)	13.87 (6.29)			
656	18	(450)	24	24	24	14 <sup>3</sup> / <sub>16</sub> (360.36)	-- --	12 <sup>1</sup> / <sub>4</sub> (311.15)	13 <sup>5</sup> / <sub>8</sub> (346.08)	3 (76.20)	7200 (32.03)	13.87 (6.29)			
656	20	(500)	24	--	24	15 <sup>1</sup> / <sub>4</sub> (387.35)	-- --	13 <sup>5</sup> / <sub>16</sub> (338.14)	14 <sup>3</sup> / <sub>4</sub> (374.65)	3 (76.20)	7200 (32.03)	14.51 (6.58)			
656	24	(600)	30	--	30	18 <sup>1</sup> / <sub>16</sub> (458.79)	-- --	15 <sup>1</sup> / <sub>4</sub> (387.35)	17 (431.80)	3 (76.20)	7200 (32.03)	15.86 (7.19)			
656	30	(750)	--	--	36-42	-- --	-- --	18 <sup>1</sup> / <sub>8</sub> (460.38)	20 <sup>3</sup> / <sub>8</sub> (517.53)	3 (76.20)	7200 (32.03)	17.61 (7.99)			
656	36	(900)	--	--	36-42	-- --	-- --	21 <sup>1</sup> / <sub>8</sub> (536.58)	23½ (596.90)	3 (76.20)	7200 (32.03)	19.61 (8.90)			
658	2	(50)	8	10	8-10	6 <sup>3</sup> / <sub>16</sub> (157.16)	6 <sup>1</sup> / <sub>16</sub> (153.99)	5 <sup>1</sup> / <sub>16</sub> (128.59)	6 <sup>1</sup> / <sub>8</sub> (155.58)	4 <sup>3</sup> / <sub>16</sub> (106.36)	1800 (8.01)	5.60 (2.54)			
658	2½	(65)	8	10	8-10	6 <sup>7</sup> / <sub>16</sub> (163.51)	6 <sup>3</sup> / <sub>8</sub> (161.93)	5 <sup>7</sup> / <sub>16</sub> (138.11)	6½ (165.10)	4 <sup>7</sup> / <sub>16</sub> (112.71)	1800 (8.01)	5.60 (2.54)			
658	3	(80)	8	12	8-10	6 <sup>1</sup> / <sub>4</sub> (177.80)	6 <sup>1</sup> / <sub>16</sub> (176.21)	5 <sup>3</sup> / <sub>16</sub> (147.64)	6 <sup>7</sup> / <sub>8</sub> (174.63)	4 <sup>1</sup> / <sub>8</sub> (104.78)	1800 (8.01)	5.60 (2.54)			
658	3½	(90)	10	12	8-10	7 (177.80)	7 <sup>1</sup> / <sub>8</sub> (180.98)	5 <sup>5</sup> / <sub>16</sub> (150.81)	7 <sup>1</sup> / <sub>16</sub> (179.39)	4 <sup>3</sup> / <sub>8</sub> (111.13)	1800 (8.01)	5.90 (2.68)			
658	4	(100)	10	12	8-10	7 <sup>5</sup> / <sub>8</sub> (193.68)	7 <sup>5</sup> / <sub>8</sub> (193.68)	6 <sup>1</sup> / <sub>2</sub> (165.10)	7 <sup>9</sup> / <sub>16</sub> (192.09)	4 <sup>1</sup> / <sub>8</sub> (104.78)	1800 (8.01)	5.90 (2.68)			
658	5	(125)	12	14	8-10	8 <sup>3</sup> / <sub>16</sub> (207.96)	8 <sup>3</sup> / <sub>8</sub> (212.73)	7 <sup>1</sup> / <sub>8</sub> (180.98)	8 <sup>3</sup> / <sub>16</sub> (207.96)	4 <sup>1</sup> / <sub>4</sub> (107.95)	1800 (8.01)	5.90 (2.68)			
658	6	(150)	14	16	12-14	9 (228.60)	9 (228.60)	7 <sup>9</sup> / <sub>16</sub> (192.09)	8 <sup>3</sup> / <sub>4</sub> (222.25)	4 <sup>3</sup> / <sub>16</sub> (106.36)	1800 (8.01)	10.68 (4.84)			
658	8	(200)	16	18	12-14	10 <sup>1</sup> / <sub>8</sub> (257.18)	10 <sup>1</sup> / <sub>8</sub> (257.18)	8 <sup>1</sup> / <sub>16</sub> (220.66)	9 <sup>7</sup> / <sub>8</sub> (250.83)	4 <sup>3</sup> / <sub>16</sub> (106.36)	1800 (8.01)	10.68 (4.84)			
658	10	(250)	18	20	16-20	11 <sup>1</sup> / <sub>4</sub> (285.75)	11 <sup>1</sup> / <sub>4</sub> (285.75)	9 <sup>3</sup> / <sub>4</sub> (247.65)	11 <sup>1</sup> / <sub>8</sub> (282.58)	4 <sup>1</sup> / <sub>8</sub> (104.78)	1800 (8.01)	11.40 (5.17)			
658	12	(300)	20	24	16-20	12 <sup>3</sup> / <sub>8</sub> (314.33)	-- --	10 <sup>1</sup> / <sub>3</sub> (274.64)	12 <sup>3</sup> / <sub>16</sub> (309.56)	4 <sup>1</sup> / <sub>8</sub> (104.78)	5000 (22.24)	14.43 (6.55)			
658	14	(350)	20	24	24	12 <sup>7</sup> / <sub>8</sub> (327.03)	-- --	11 <sup>5</sup> / <sub>16</sub> (287.34)	12 <sup>5</sup> / <sub>8</sub> (320.68)	4 (101.60)	5000 (22.24)	14.43 (6.55)			
658	16	(400)	24	24	24	14 <sup>1</sup> / <sub>8</sub> (358.78)	-- --	12 <sup>3</sup> / <sub>16</sub> (309.56)	13 <sup>5</sup> / <sub>8</sub> (346.08)	4 (101.60)	7200 (32.03)	15.79 (7.16)			
658	18	(450)	24	--	24	15 <sup>1</sup> / <sub>4</sub> (387.35)	-- --	13 <sup>5</sup> / <sub>16</sub> (338.14)	14 <sup>3</sup> / <sub>4</sub> (374.65)	4 (101.60)	7200 (32.03)	15.79 (7.16)			
658	20	(500)	30	--	30	17 (431.80)	-- --	14 <sup>1</sup> / <sub>8</sub> (358.78)	15 <sup>7</sup> / <sub>8</sub> (403.23)	4 (101.60)	7200 (32.03)	16.90 (7.67)			
658	24	(600)	30	--	30	19 <sup>1</sup> / <sub>4</sub> (488.95)	-- --	16 <sup>7</sup> / <sub>16</sub> (417.51)	19 <sup>1</sup> / <sub>4</sub> (488.95)	4 (101.60)	7200 (32.03)	17.78 (8.06)			
658	30	(750)	--	--	36-42	-- --	-- --	19 <sup>3</sup> / <sub>16</sub> (487.36)	20 <sup>15</sup> / <sub>16</sub> (531.81)	4 (101.60)	7200 (32.03)	20.08 (9.11)			
658	36	(900)	--	--	36-42	-- --	-- --	22 <sup>3</sup> / <sub>16</sub> (563.56)	24 (609.60)	4 (101.60)	7200 (32.03)	22.16 (10.05)			

Maximum recommended loads are applicable only when the saddle is used on a flat bearing surface and tack welded to the pipe. When a saddle is used with a pipe roll, the maximum load given for the pipe roll applies to the saddle.

Unless otherwise specified, all dimensions on drawings and in charts are in inches and dimensions shown in parentheses are in millimeters.

## FIG. 670 - 678

## PIPE ALIGNMENT GUIDES

**Function:** Designed for use with insulated or non-insulated pipe lines to direct the axial expansion and contraction of the pipe. The use of two or more guides on both sides of the expansion joint is recommended to avoid a pivoting effect. The first pipe guide should be placed a maximum of 4 pipe diameters from an expansion joint. Pipe guides are not designed to support any of the piping system's weight therefore additional supports are required. The maximum operating temperature should not exceed 750°F (399° C).

**Material:** Carbon steel

**Finish:** Painted

**Install:** The use of non-insulated guides with expansion joints shall be controlled by the recommendation of the expansion joint manufacturer (or in accordance with the Expansion Joint Manufacturers Association (EJMA) guidelines).

**Ordering:** Specify figure number and pipe size.

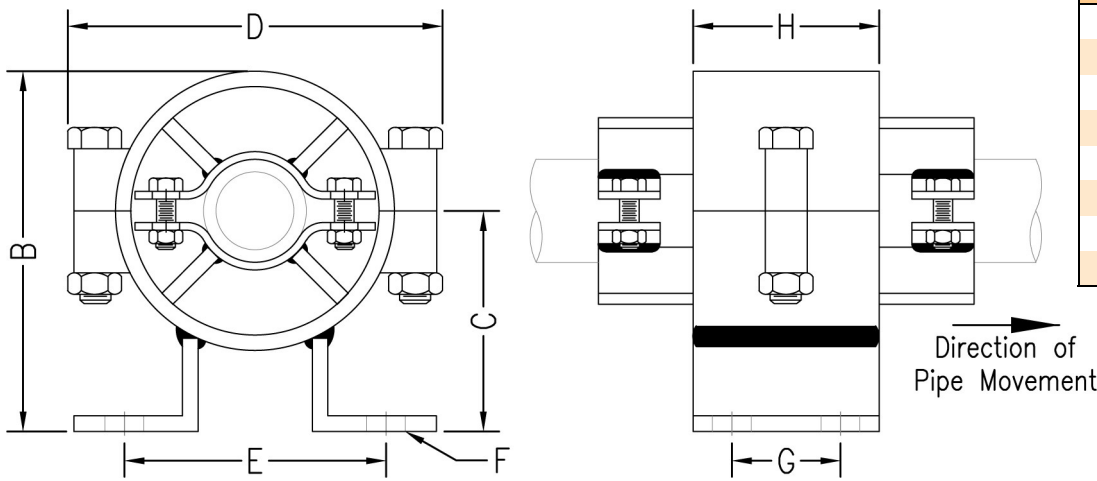

Fig. Number	Insulation Thickness	
670	0	(0)
671	1	(25.4)
673	1½	(38.1)
674	2	(50.8)
675	2½	(63.5)
676	3	(76.2)
677	3½	(88.9)
678	4	(101.6)

Body No.	B		C		D		E		F		G		H		Axial Movement		Wt. Each	
	in	mm	in	mm	in	mm	in	mm	in	mm	in	mm	in	mm	in	mm	lbs.	kg
4	5 7/8	(149.23)	3 1/2	(88.90)	6 1/8	(155.58)	4 1/8	(104.78)	5/8	(15.88)	1 3/4	(44.45)	3	(76.20)	3	(76.20)	6	(2.72)
5	6 3/4	(171.45)	4	(101.60)	7 1/8	(180.98)	4 3/8	(111.13)	5/8	(15.88)	1 3/4	(44.45)	3	(76.20)	3	(76.20)	8	(3.63)
6	7 5/8	(193.68)	4 3/8	(111.13)	8 1/8	(206.38)	5 1/8	(130.18)	5/8	(15.88)	1 3/4	(44.45)	3	(76.20)	3	(76.20)	10	(4.54)
8	9 1/4	(234.95)	5 1/4	(133.35)	10 1/8	(257.18)	6 1/8	(155.58)	5/8	(15.88)	1 3/4	(44.45)	3	(76.20)	3	(76.20)	13	(5.90)
10	11 5/8	(295.28)	6 1/4	(158.75)	12 1/8	(307.98)	7	(177.80)	5/8	(15.88)	2 3/4	(69.85)	4	(101.60)	4	(101.60)	20	(9.07)
12	13 3/8	(339.73)	7	(177.80)	14 1/8	(358.78)	8 1/4	(209.55)	5/8	(15.88)	2 3/4	(69.85)	4	(101.60)	4	(101.60)	25	(11.34)
14	15 1/8	(384.18)	7 7/8	(200.03)	16 1/8	(409.58)	9 7/8	(250.83)	3/4	(19.05)	4	(101.60)	6	(152.40)	6	(152.40)	40	(18.14)
16	17	(431.80)	8 7/8	(225.43)	18 1/8	(460.38)	10 7/8	(276.23)	3/4	(19.05)	4	(101.60)	6	(152.40)	6	(152.40)	45	(20.41)
18	18 3/4	(476.25)	9 3/4	(247.65)	20 1/8	(511.18)	11 7/8	(301.63)	3/4	(19.05)	4	(101.60)	6	(152.40)	6	(152.40)	55	(24.95)
20	21	(533.40)	10 7/8	(276.23)	22 1/8	(561.98)	11 3/4	(298.45)	3/4	(19.05)	6	(152.40)	8	(203.20)	6	(152.40)	65	(29.48)
22	23 1/8	(587.38)	12 1/8	(307.98)	24 1/8	(612.78)	14 1/2	(368.30)	7/8	(22.23)	6	(152.40)	8	(203.20)	6	(152.40)	95	(43.09)
24	25	(635.00)	13	(330.20)	26 1/8	(663.58)	15 1/2	(393.70)	7/8	(22.23)	6	(152.40)	8	(203.20)	6	(152.40)	115	(52.16)
26	27 3/4	(704.85)	14 3/4	(374.65)	28 1/8	(714.38)	17 1/8	(434.98)	1 1/8	(28.58)	6	(152.40)	8	(203.20)	6	(152.40)	135	(61.23)
30	31 1/2	(800.10)	16 1/2	(419.10)	32 1/8	(815.98)	19 1/4	(488.95)	1 1/8	(28.58)	6	(152.40)	8	(203.20)	6	(152.40)	150	(68.04)

Unless otherwise specified, all dimensions on drawings and in charts are in inches and dimensions shown in parentheses are in millimeters.

# PIPE GUIDE CHARTS



## PIPE GUIDE SELECTION CHART FIG. 670 - 678

Pipe Size		Body No.							
		Insulation Thickness							
		Fig. 670 None	Fig. 671 1 (25.4)	Fig. 673 1½ (38.1)	Fig. 674 2 (50.8)	Fig. 675 2½ (63.5)	Fig. 676 3 (76.2)	Fig. 677 3½ (88.9)	Fig. 678 4 (101.6)
½	(15)	4	4	4	5	6	8	8	10
¾	(20)	4	4	5	6	8	8	10	10
1	(25)	4	4	5	6	8	8	10	20
1¼	(32)	4	4	5	6	8	8	10	10
1½	(40)	5	5	5	6	8	8	10	10
2	(50)	5	5	6	8	8	10	10	12
2½	(65)	6	6	6	8	8	10	10	12
3	(80)	6	6	8	8	10	10	12	12
4	(100)	8	8	8	10	10	12	12	14
5	(125)	10	10	10	10	12	12	16	16
6	(150)	10	10	10	12	12	14	16	16
8	(200)	12	12	12	14	16	16	18	18
10	(250)	16	16	16	16	18	18	20	20
12	(300)	18	18	18	18	20	20	22	22
14	(350)	20	20	20	20	20	22	22	24
16	(400)	22	22	22	22	22	24	24	26
18	(450)	24	24	24	24	24	26	26	30
20	(500)	26	26	26	26	26	30	30	30
24	(600)	30	30	30	30	30	--	--	--

Use selection chart to determine body number for dimensional purposes.

## PIPE GUIDE SPACING CHART FIG. 670 - 678

Pipe Size		Max. Distance Between Intermediate Guides for Pressure (psig)																			
		50		100		150		200		250		300		350		400		500		600	
		ft.	m	ft.	m	ft.	m	ft.	m	ft.	m	ft.	m	ft.	m	ft.	m	ft.	m	ft.	m
3	(80)	38	(11.58)	27	(8.23)	22	(6.71)	20	(6.10)	18	(5.49)	17	(5.18)	15	(4.57)	14	(4.27)	13	(3.96)	12	(3.66)
4	(100)	52	(15.85)	37	(11.28)	32	(9.75)	27	(8.23)	25	(7.62)	23	(7.01)	22	(6.71)	19	(5.79)	17	(5.18)	16	(4.88)
6	(150)	66	(20.12)	47	(14.33)	40	(12.19)	35	(10.67)	31	(9.45)	28	(8.53)	27	(8.23)	25	(7.62)	23	(7.01)	20	(6.10)
8	(200)	85	(25.91)	62	(18.90)	51	(15.54)	45	(13.72)	40	(12.19)	36	(10.97)	35	(10.67)	32	(9.75)	29	(8.84)	27	(8.23)
10	(250)	103	(31.39)	75	(22.86)	62	(18.90)	54	(16.46)	50	(15.24)	45	(13.72)	42	(12.80)	40	(12.19)	35	(10.67)	32	(9.75)
12	(300)	118	(35.97)	85	(25.91)	70	(21.34)	60	(18.29)	55	(16.76)	50	(15.24)	46	(14.02)	43	(13.11)	40	(12.19)	35	(10.67)
14	(350)	120	(36.58)	87	(26.52)	72	(21.95)	62	(18.90)	57	(17.37)	52	(15.85)	48	(14.63)	45	(13.72)	41	(12.50)	37	(11.28)
16	(400)	130	(39.62)	95	(28.96)	78	(23.77)	68	(20.73)	61	(18.59)	57	(17.37)	52	(15.85)	49	(14.94)	45	(13.72)	41	(12.50)
18	(450)	145	(44.20)	105	(32.00)	87	(26.52)	75	(22.86)	68	(20.73)	62	(18.90)	58	(17.68)	55	(16.76)	50	(15.24)	45	(13.72)
20	(500)	155	(47.24)	110	(33.53)	92	(28.04)	90	(27.43)	73	(22.25)	68	(20.73)	62	(18.90)	58	(17.68)	53	(16.15)	49	(14.94)
24	(600)	180	(54.86)	128	(39.01)	105	(32.00)	90	(27.43)	83	(25.30)	75	(22.86)	70	(21.34)	65	(19.81)	60	(18.29)	54	(16.46)

*Note: The first pipe guide should be placed a maximum of 4 pipe diameters from an expansion joint.*

Unless otherwise specified, all dimensions on drawings and in charts are in inches and dimensions shown in parentheses are in millimeters.

- THREADED ACCESSORIES
- CPVC STRAPS
- BAND HANGERS
- BEAM CLAMPS
- CLEVIS HANGERS
- PIPE ROLLER SUPPORTS
- SPLIT RING HANGERS
- PIPE CLAMPS
- CENTER LOAD BEAM CLAMPS
- PIPE SHIELDS, INSULATION, & SADDLES
- PIPE GUIDES & SLIDES
- WALL BRACKETS
- PIPE SUPPORTS
- STRUCTURAL ATTACHMENTS
- SEISMIC BRACING

# PIPE SLIDE ASSEMBLY

**FIG. 690**

## PIPE SLIDE ASSEMBLY

**Function:** Designed to be welded directly to the pipe to allow for support from below and allow for horizontal movement with a low coefficient of friction. The assembly consists of a carbon steel tee with a polished stainless bottom which rests on a PTFE (glass filled teflon) plate, bonded to a carbon steel plate. The base plate configuration will vary with the Type selected.

**Material:** Carbon Steel, Stainless Steel, PTFE.

**Finish:** Plain, Painted, or Hot dipped galvanized.

**Approvals:** Complies with Federal Specifications A-A-1192A (Type 35) and Manufacturers' Standardization Society ANSI/SP-58 (Type 35).

**Ordering:** Specify figure number, pipe size, type, finish, and travel.

**Maximum Temperature:**

200°F (93°C) at the sliding surface

*NOTE: Greater height dimensions, longer transverse and longitudinal movements, and other customer requirements can be supplied upon request.*

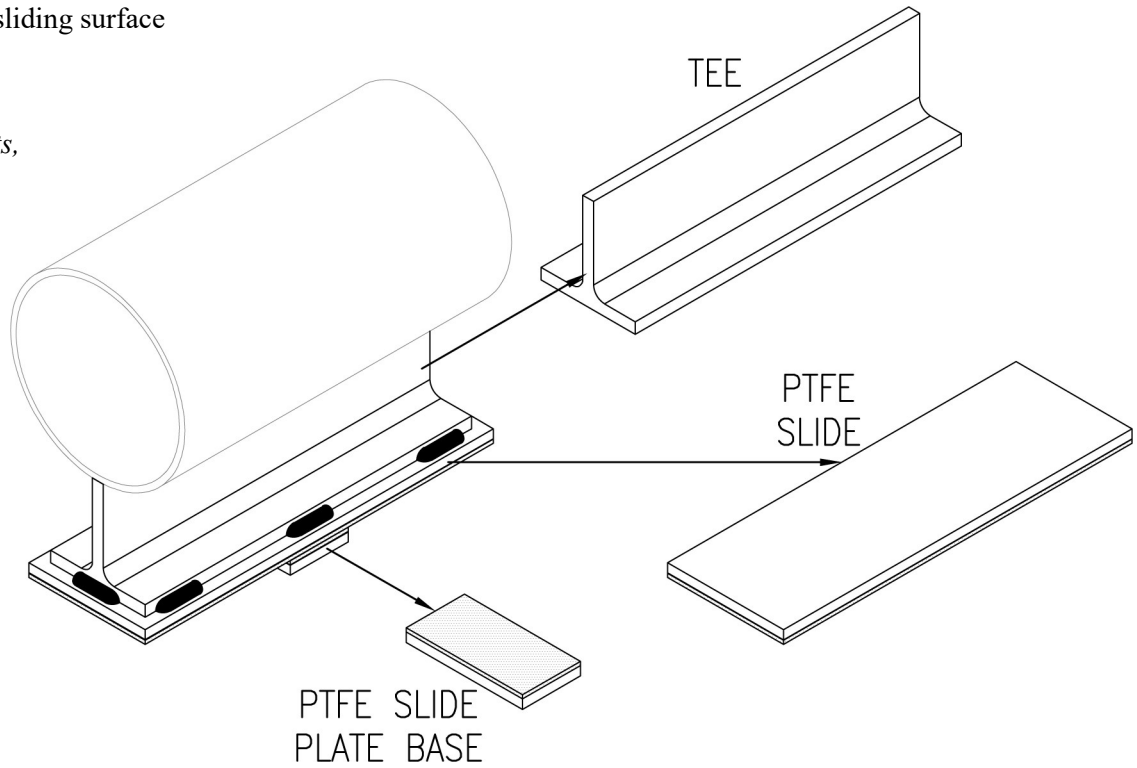

Pipe Size	Travel	H		K Type 2 & 3	L	W	X Type 2 & 3	Weight Each Type 1		Max Load	
		Type 1	Type 2 & 3					lbs.	kg	lbs.	kN
Up to 8" (Up to 200)	5 (127)	3 3/4 (95.25)	4 1/4 (107.95)	4 (101.6)	8 1/2 (215.9)	3 1/2 (88.9)	6 (152.4)	7 (3.18)	7000 (31.14)		
	10 (254)				13 1/2 (342.9)			10 (4.54)			
	15 (381)				18 1/2 (469.9)			13 (5.90)			
	20 (508)				23 1/2 (596.9)			17 (7.71)			
10" - 24" (250 - 600)	5 (127)	3 3/4 (95.25)	4 1/4 (107.95)	6 (152.4)	10 1/2 (266.7)	4 1/2 (114.3)	7 (177.8)	11 (4.99)	13500 (60.05)		
	10 (254)				15 1/2 (393.7)			15 (6.80)			
	15 (381)				20 1/2 (520.7)			19 (8.62)			
	20 (508)				25 1/2 (647.7)			23 (10.43)			

Loads based upon 500 psi / 35.2 Kg per sq. cm. pressure on the PTFE

# PIPE SLIDE ASSEMBLY



- THREADED ACCESSORIES
- CPVC STRAPS
- BAND HANGERS
- BEAM CLAMPS
- CLEVIS HANGERS
- PIPE ROLLER SUPPORTS
- SPLIT RING HANGERS
- PIPE CLAMPS
- CENTER LOAD BEAM CLAMPS
- PIPE SHIELDS, INSULATION, & SADDLES
- PIPE GUIDES & SLIDES
- WALL BRACKETS
- PIPE SUPPORTS
- STRUCTURAL ATTACHMENTS
- SEISMIC BRACING

## PIPE SLIDE ASSEMBLY FIG. 690

### Type 1

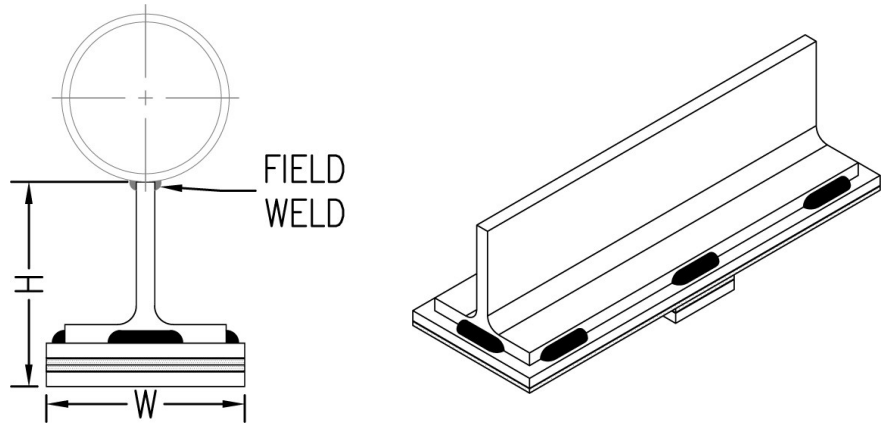

### Type 2 Base with guides.

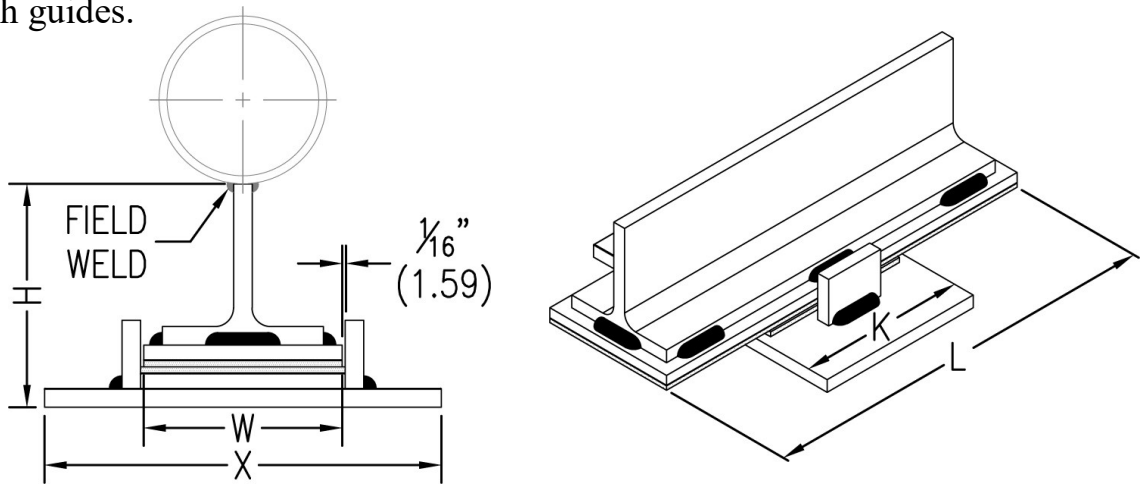

### Type 3 Base with guides and hold down lugs.

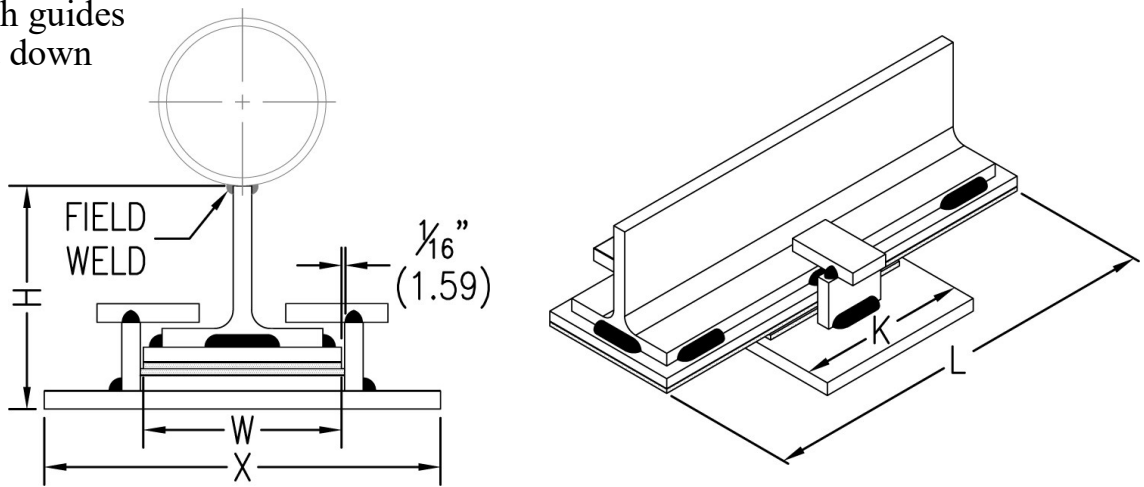

Unless otherwise specified, all dimensions on drawings and in charts are in inches and dimensions shown in parentheses are in millimeters.

# WALL BRACKETS

**FIG. 850**

## LIGHT DUTY WALL BRACKET

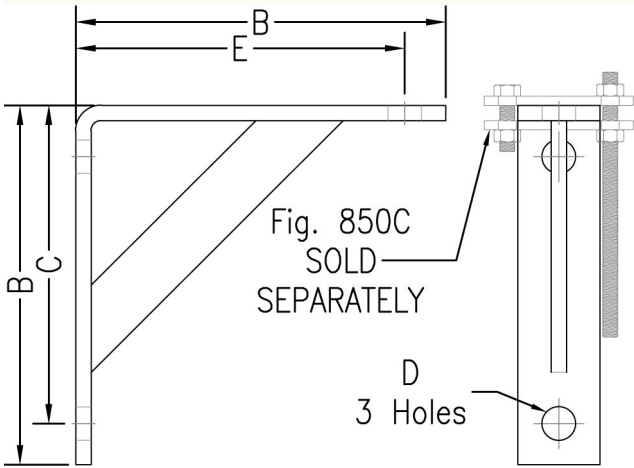

**Function:** Designed to suspend hanger rod for support of light loads under 750 lbs. Normally used in conjunction with Fig. 850C wall bracket clip.

**Material:** Carbon steel (Type 304 or 316 Stainless Steel upon request)

**Finish:** Plain or electro-galvanized (Hot dipped galvanized upon request)

**Approvals:** Complies with Federal Specification A-A-1192A (Type 31) and Manufacturers' Standardization Society ANSI/MSS SP-58 (Type 31) which supersedes ANSI/MSS SP-69.

**Ordering:** Specify figure number, type number, material, and finish.

Type Number	B		C		Hole Size D		E		Max. Rec. Load		Wt. Each	
	in	mm	in	mm	in	mm	in	mm	lbs.	kN	lbs.	kg
1	9	(228.6)	6 1/2	(165.1)	13/16	(20.64)	8	(203.2)	750	(3.34)	6.00	(2.72)
2	13	(330.2)	10 1/2	(266.7)	13/16	(20.64)	12	(304.8)	750	(3.34)	8.70	(3.95)
3	19	(482.6)	16 1/2	(419.1)	13/16	(20.64)	18	(457.2)	750	(3.34)	10.60	(4.81)

**FIG. 850C**

## WALL BRACKET CLIP (For Fig. 850)

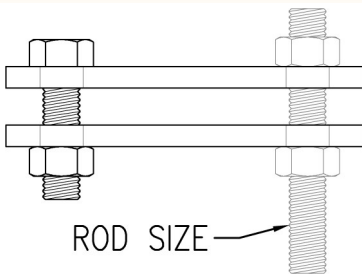

**Function:** Designed for use in conjunction with Fig. 850 wall bracket, to allow the rod to be suspended at any point along the length of the bracket.

**Material:** Carbon steel (Type 304 or 316 Stainless Steel upon request)

**Finish:** Plain or electro-galvanized (Hot dipped galvanized with electro-galvanized hardware upon request)

**Ordering:** Specify figure number, rod size, material, and finish.

Rod Size	For Pipe Sizes		Wt. Each	
	in	mm	lbs.	kg
3/8	1/2 to 2	(15 to 50)	.73	(.33)
1/2	2 1/2 to 3 1/2	(65 to 90)	1.44	(.65)



# WALL BRACKETS



## MEDIUM DUTY WALL BRACKET

FIG. 855

- Function:** Designed for the support or suspension of loads up to 1500 lbs. (6.67kN). from walls or structures. The 1" (25.4) space between the angles allows the rod to be placed anywhere along the length of the brackets.
- Material:** Carbon steel (Type 304 or 316 Stainless Steel upon request)
- Finish:** Plain or electro-galvanized (Hot dipped galvanized upon request)
- Approvals:** Complies with Federal Specification A-A-1192A (Type 32) and Manufacturers' Standardization Society ANSI/MSS SP-58 (Type 32) which supersedes ANSI/MSS SP-69.
- Ordering:** Specify figure number, type number, material, and finish.

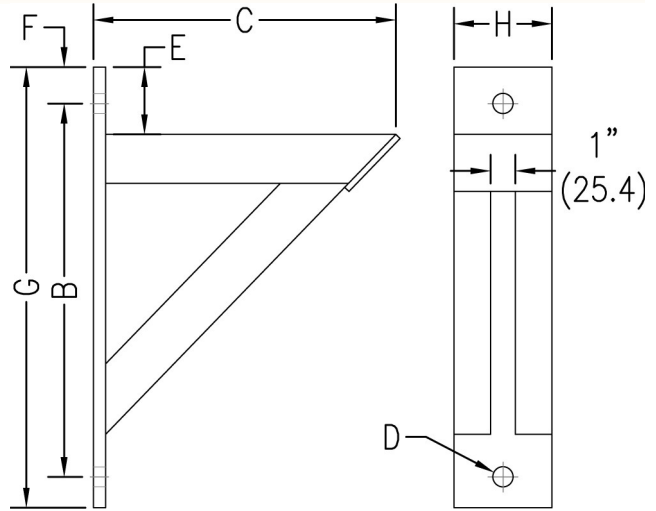

Type Number	B		C		Hole Size D		E		F		G		H		Max. Rec. Load		Wt. Each	
	in	mm	in	mm	in	mm	in	mm	in	mm	in	mm	in	mm	lbs.	kN	lbs.	kg
0	15 1/2	(393.7)	12	(304.8)	1 3/16	(20.64)	2 1/2	(63.5)	1 1/4	(31.75)	18	(457.2)	4	(101.6)	1500	(6.67)	17.4	(7.89)
1	21 1/2	(546.1)	18	(457.2)	1 3/16	(20.64)	2 1/2	(63.5)	1 1/4	(31.75)	24	(609.6)	4 1/2	(114.3)	1500	(6.67)	27.3	(12.38)
2	27 1/2	(698.5)	24	(609.6)	1 3/16	(20.64)	2 1/2	(63.5)	1 1/4	(31.75)	30	(762.0)	5	(127.0)	1500	(6.67)	47.6	(21.59)

## HEAVY DUTY WALL BRACKET

FIG. 860

- Function:** Designed for the support or suspension of loads up to 3000 lbs. (13.34kN). from walls or structures. The 1" (25.4) space between the angles allows the rod to be placed anywhere along the length of the brackets.
- Material:** Carbon steel (Type 304 or 316 Stainless Steel upon request)
- Finish:** Plain or electro-galvanized (Hot dipped galvanized upon request)
- Approvals:** Complies with Federal Specification A-A-1192A (Type 33) and Manufacturers' Standardization Society ANSI/MSS SP-58 (Type 33) which supersedes ANSI/MSS SP-69.
- Ordering:** Specify figure number, type number, material, and finish.

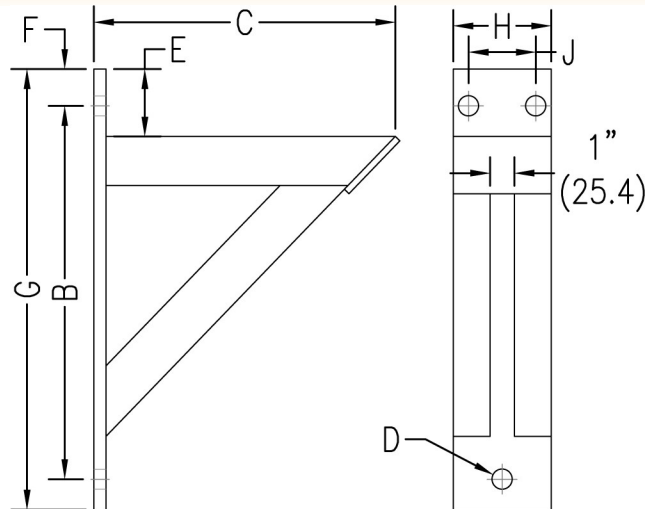

Type Number	B		C		Hole Size D		E		F		G		H		J		Max. Rec. Load		Wt. Each	
	in	mm	in	mm	in	mm	in	mm	in	mm	in	mm	in	mm	in	mm	lbs.	kN	lbs.	kg
0	15 1/4	(387.35)	12	(304.80)	1 3/16	(20.64)	2 3/4	(69.85)	1 1/2	(38.10)	18	(457.2)	4	(101.6)	*	*	3000	(13.34)	24.33	(11.04)
1	21 3/8	(542.93)	18	(457.20)	1 5/16	(23.81)	2 3/4	(69.85)	1 3/8	(34.93)	24	(609.6)	5	(127.0)	2 3/4	(69.85)	3000	(13.34)	51.80	(23.50)
2	27 1/2	(698.50)	24	(609.60)	1 1/16	(26.99)	2 3/4	(69.85)	1 1/4	(31.75)	30	(762.0)	5	(127.0)	2 1/2	(63.50)	3000	(13.34)	65.84	(29.86)
3	33 1/4	(844.55)	30	(762.00)	1 1/16	(26.99)	3	(76.20)	1 1/2	(38.10)	36	(914.4)	5	(127.0)	2 1/2	(63.50)	3000	(13.34)	82.10	(37.24)
4	39	(990.60)	36	(914.40)	1 1/16	(26.99)	3	(76.20)	1 1/2	(38.10)	42	(1066.8)	6	(152.4)	3 1/2	(88.90)	3000	(13.34)	140.52	(63.74)
5	46	(1168.40)	42	(1066.80)	1 1/16	(26.99)	3 1/2	(88.90)	2	(50.80)	50	(1270.0)	6	(152.4)	3 1/2	(88.90)	3000	(13.34)	166.40	(75.48)

\* One hole

Unless otherwise specified, all dimensions on drawings and in charts are in inches and dimensions shown in parentheses are in millimeters.

THREADED ACCESSORIES  
CPVC STRAPS  
BAND HANGERS  
BEAM CLAMPS  
CLEVIS HANGERS  
PIPE ROLLER SUPPORTS  
SPLIT RING HANGERS  
PIPE CLAMPS  
CENTER LOAD BEAM CLAMPS  
PIPE SHIELDS, INSULATION, & SADDLES  
PIPE GUIDES & SLIDES  
WALL BRACKETS  
PIPE SUPPORTS  
STRUCTURAL ATTACHMENTS  
SEISMIC BRACING

# PIPE SUPPORTS

**FIG. 870**

## PIPE SADDLE SUPPORT WITH COUPLING

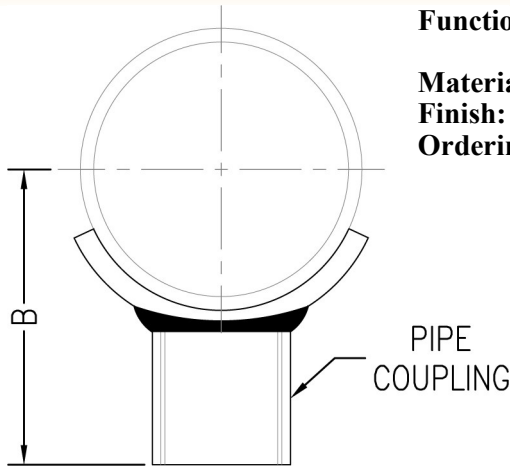

**Function:** Designed to support horizontal pipe from floor stanchions. Normally used in conjunction with Fig. 871 threaded base stand.

**Material:** Carbon steel (Type 304 or 316 Stainless Steel upon request)

**Finish:** Plain or electro-galvanized

**Ordering:** Specify figure number, pipe size, material, and finish.

Pipe Size		Coupling Pipe Size	B		Wt. Each	
					lbs.	kg
1½	(40)	1¼	3¼	(82.55)	.85	(.39)
2	(50)	1¼	3⅝	(92.08)	1.12	(.51)
2½	(65)	1½	3⅞	(98.43)	1.62	(.73)
3	(80)	1½	4⅜	(106.36)	1.79	(.81)
3½	(90)	1½	4⅞	(112.71)	1.94	(.88)
4	(100)	2	4¾	(120.65)	2.73	(1.24)
5	(125)	2	5⅝	(134.94)	3.09	(1.40)
6	(150)	2½	6⅝	(176.21)	5.86	(2.66)
8	(200)	2½	7⅝	(201.61)	6.88	(3.12)
10	(250)	3	9⅞	(231.78)	10.11	(4.59)
12	(300)	3	10⅞	(257.18)	11.28	(5.12)

**FIG. 871**

## THREADED BASE STAND

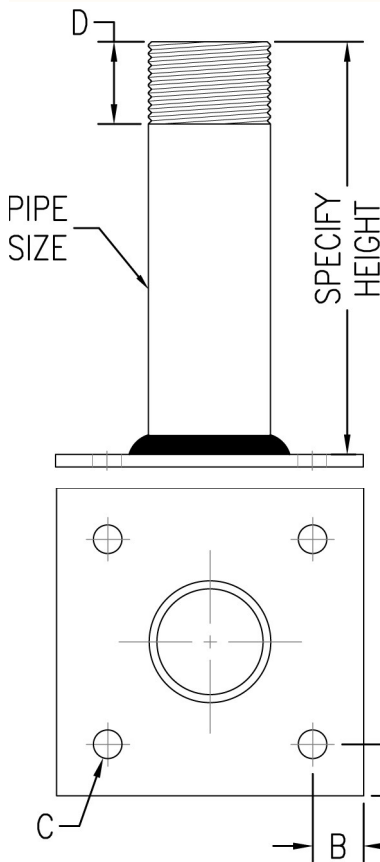

**Function:** Designed for use as a base stand for pipe supports.

**Material:** Carbon steel (Type 304 or 316 Stainless Steel upon request)

**Finish:** Plain or electro-galvanized (Hot dipped galvanized upon request)

**Ordering:** Specify figure number, pipe size, height, material, and finish.

*NOTE: PHD Manufacturing Inc. is not responsible for the quality of the pipe threads if the product is supplied with hot dipped galvanized finish.*

Pipe Size	B	Hole Size C		Thread Length D		Plate Size		Wt. Each			
								lbs.	kg		
1	(25)	1	(25.40)	⅜	(14.29)	1½	(38.10)	¼ x 6 x 6	(6.35 x 152.4 x 152.4)	4.95	(2.25)
1¼	(32)	1	(25.40)	⅜	(14.29)	1½	(38.10)	¼ x 6 x 6	(6.35 x 152.4 x 152.4)	5.83	(2.64)
1½	(40)	1	(25.40)	⅜	(14.29)	1½	(38.10)	¼ x 6 x 6	(6.35 x 152.4 x 152.4)	6.49	(2.94)
2	(50)	1	(25.40)	⅜	(14.29)	1½	(38.10)	¼ x 6 x 6	(6.35 x 152.4 x 152.4)	7.85	(3.56)
2½	(65)	1¼	(31.75)	⅜	(14.29)	1½	(38.10)	⅜ x 8 x 8	(9.53 x 203.2 x 203.2)	15.24	(6.91)
3	(80)	1½	(38.10)	⅜	(20.64)	1½	(38.10)	⅜ x 12 x 12	(9.53 x 304.8 x 304.8)	26.24	(11.90)
4	(100)	1½	(38.10)	⅜	(23.81)	2	(50.80)	½ x 12 x 12	(12.7 x 304.8 x 304.8)	35.94	(16.30)
6	(150)	1½	(38.10)	1⅜	(28.58)	2	(50.80)	½ x 18 x 18	(12.7 x 457.2 x 457.2)	73.46	(33.32)

# PIPE SUPPORTS



## PIPE SADDLE SUPPORT WITH STUD

**FIG. 874**

**Function:** Designed for support of horizontal pipe from floor stand where vertical adjustment is required. Shank will fit into Schedule 40 pipe size stand 'B'.

**Material:** Carbon steel (Type 304 or 316 Stainless Steel upon request)

**Finish:** Plain or electro-galvanized

**Approvals:** Complies with Federal Specification A-A-1192A (Type 38) and Manufacturers' Standardization Society ANSI/MSS SP-58 (Type 38) which supersedes ANSI/MSS SP-69.

**Ordering:** Specify figure number, pipe size, material, and finish.

Pipe Size		Thread Size A	Max. O.D. of Pipe		Sch. 40 Pipe Size B		Wt. Each	
							lbs.	kg
2	(50)	7/8	2 3/8	(60.33)	1	(25)	1.67	(.76)
2 1/2	(65)	7/8	2 7/8	(73.03)	1	(25)	1.71	(.78)
3	(80)	7/8	3 1/2	(88.90)	1	(25)	1.76	(.80)
3 1/2	(90)	1	4	(101.60)	1	(25)	3.45	(1.56)
4	(100)	1	4 1/2	(114.30)	1	(25)	3.60	(1.63)
5	(125)	1	5 9/16	(141.29)	1	(25)	3.81	(1.73)
6	(150)	1 1/4	6 5/8	(168.28)	1 1/4	(32)	5.50	(2.49)
8	(200)	1 1/4	8 5/8	(219.08)	1 1/4	(32)	7.00	(3.18)
10	(250)	1 1/2	10 3/4	(273.05)	1 1/2	(40)	7.66	(3.47)
12	(300)	1 1/2	12 3/4	(323.85)	1 1/2	(40)	8.95	(4.06)

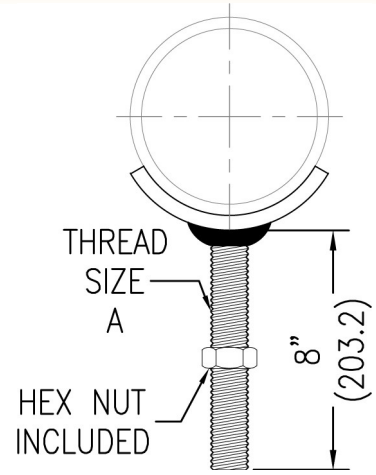

## ADJUSTABLE PIPE SADDLE SUPPORT

**FIG. 875**

**Function:** Designed to support horizontal pipe. Normally used in conjunction with Fig. 871 threaded base stand to provide vertical adjustment of the pipe.

**Material:** Carbon steel with malleable iron reducer

**Finish:** Plain or electro-galvanized (Hot dipped galvanized with electro-galvanized threaded components upon request)

**Approvals:** Complies with Federal Specification A-A-1192A (Type 38) and Manufacturers' Standardization Society ANSI/MSS SP-58 (Type 38) which supersedes ANSI/MSS SP-69.

**Ordering:** Specify figure number, pipe size, and finish.

*NOTE: Gussets furnished on 8" (200) and larger.*

Pipe Size		B		C		D		Adjustment E		Max. Rec. Load		Wt. Each			
								Min.	Max.	lbs.	kN	lbs.	kg		
2 1/2	(65)	2 1/2	(63.50)	3 11/16	(93.66)	1 1/2	(38.10)	9 7/16	(239.71)	13 15/16	(354.01)	1800	(8.01)	5.25	(2.38)
3	(80)	2 1/2	(63.50)	4	(101.60)	1 1/2	(38.10)	9 3/4	(247.65)	14 1/4	(361.95)	1800	(8.01)	5.50	(2.49)
3 1/2	(90)	2 1/2	(63.50)	4 1/4	(107.95)	1 1/2	(38.10)	10	(254.00)	14 1/2	(368.30)	1800	(8.01)	5.50	(2.49)
4	(100)	3	(76.20)	4 1/2	(114.30)	2 1/2	(63.50)	10 3/4	(273.05)	15 1/4	(387.35)	3800	(16.90)	10.60	(4.81)
5	(125)	3	(76.20)	5 1/16	(128.59)	2 1/2	(63.50)	11 5/16	(287.34)	15 3/16	(401.64)	3800	(16.90)	10.81	(4.90)
6	(150)	3	(76.20)	5 11/16	(144.46)	2 1/2	(63.50)	11 15/16	(303.21)	16 7/16	(417.51)	3800	(16.90)	12.34	(5.60)
8	(200)	3	(76.20)	6 11/16	(169.86)	2 1/2	(63.50)	12 15/16	(328.61)	17 7/16	(442.91)	3800	(16.90)	15.00	(6.80)
10	(250)	3	(76.20)	7 7/8	(200.03)	2 1/2	(63.50)	14 1/8	(358.78)	18 5/8	(473.08)	3800	(16.90)	16.14	(7.32)
12	(300)	3	(76.20)	8 7/8	(225.43)	2 1/2	(63.50)	15 1/8	(384.18)	19 5/8	(498.48)	3800	(16.90)	17.68	(8.02)
14	(350)	4	(101.60)	11 5/8	(295.28)	3	(76.20)	17 3/8	(441.33)	21 7/8	(555.63)	5300	(23.58)	28.18	(12.78)
16	(400)	4	(101.60)	12 5/8	(320.68)	3	(76.20)	18 3/8	(466.73)	22 7/8	(581.03)	5300	(23.58)	30.10	(13.65)
18	(450)	6	(152.40)	14 3/4	(374.65)	4	(101.60)	20 1/2	(520.70)	25	(635.00)	6700	(29.80)	49.98	(22.67)
20	(500)	6	(152.40)	15 3/4	(400.05)	4	(101.60)	21 1/2	(546.10)	26	(660.40)	6700	(29.80)	52.00	(23.59)
24	(600)	6	(152.40)	18	(457.20)	4	(101.60)	23 3/4	(603.25)	28 1/4	(717.55)	7300	(32.47)	63.47	(28.79)
30	(750)	6	(152.40)	21	(533.40)	4	(101.60)	26 3/4	(679.45)	31 1/4	(793.75)	7300	(32.47)	92.24	(41.84)
36	(900)	6	(152.40)	24	(609.60)	4	(101.60)	29 3/4	(755.65)	34 1/4	(869.95)	7300	(32.47)	110.77	(50.24)

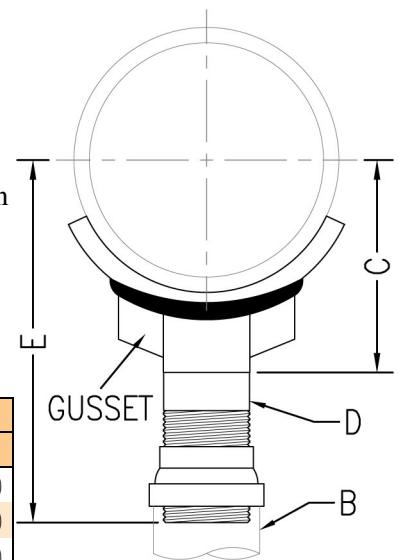

Unless otherwise specified, all dimensions on drawings and in charts are in inches and dimensions shown in parentheses are in millimeters.

THREADED ACCESSORIES  
CPVC STRAPS  
BAND HANGERS  
BEAM CLAMPS  
CLEVIS HANGERS  
PIPE ROLLER SUPPORTS  
SPLIT RING HANGERS  
PIPE CLAMPS  
CENTER LOAD BEAM CLAMPS  
PIPE SHIELDS, INSULATION, & SADDLES  
PIPE GUIDES & SLIDES  
WALL BRACKETS  
PIPE SUPPORTS  
STRUCTURAL ATTACHMENTS  
SEISMIC BRACING

# PIPE SUPPORTS

**FIG. 876**

## ADJUSTABLE PIPE SADDLE SUPPORT WITH U-BOLT

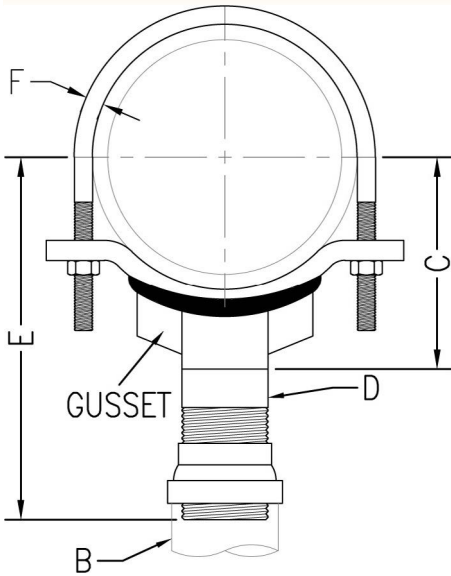

- Function:** Designed to support horizontal pipe. Normally used in conjunction with Fig. 871 threaded base stand to provide vertical adjustment of the pipe. The U-bolt is used to secure the pipe to the saddle.
- Material:** Carbon steel with malleable iron reducer
- Finish:** Plain or electro-galvanized (Hot dipped galvanized with electro-galvanized threaded components upon request)
- Approvals:** Complies with Federal Specification A-A-1192A (Type 38) and Manufacturers' Standardization Society ANSI/MSS SP-58 (Type 38) which supersedes ANSI/MSS SP-69.
- Ordering:** Specify figure number, pipe size, and finish.

*NOTE: Gussets furnished on 8" (200) and larger.*

Pipe Size	B		C		D		Adjustment E		Dia. F	Max. Rec. Load		Wt. Each	
	Min.	Max.	Min.	Max.	Min.	Max.	Min.	Max.		lbs.	kN	lbs.	kg
2 1/2 (65)	2 1/2 (63.50)	3 1/16 (93.66)	1 1/2 (38.10)	9 7/16 (239.71)	13 5/16 (354.01)	1/2 (12.70)	1800 (8.01)	8.90 (4.04)					
3 (80)	2 1/2 (63.50)	4 (101.60)	1 1/2 (38.10)	9 3/4 (247.65)	14 1/4 (361.95)	1/2 (12.70)	1800 (8.01)	9.05 (4.11)					
3 1/2 (90)	2 1/2 (63.50)	4 1/4 (107.95)	1 1/2 (38.10)	10 (254.00)	14 1/2 (368.30)	1/2 (12.70)	1800 (8.01)	9.25 (4.20)					
4 (100)	3 (76.20)	4 1/2 (114.30)	2 1/2 (63.50)	10 3/4 (273.05)	15 1/4 (387.35)	1/2 (12.70)	3800 (16.90)	13.25 (6.01)					
5 (125)	3 (76.20)	5 1/16 (128.59)	2 1/2 (63.50)	11 5/16 (287.34)	15 3/16 (401.64)	1/2 (12.70)	3800 (16.90)	13.45 (6.10)					
6 (150)	3 (76.20)	5 1/16 (144.46)	2 1/2 (63.50)	11 5/16 (303.21)	16 7/16 (417.51)	1/2 (12.70)	3800 (16.90)	16.25 (7.37)					
8 (200)	3 (76.20)	6 1/16 (169.86)	2 1/2 (63.50)	12 15/16 (328.61)	17 7/16 (442.91)	5/8 (15.88)	3800 (16.90)	17.95 (8.14)					
10 (250)	3 (76.20)	8 (203.20)	2 1/2 (63.50)	14 1/4 (361.95)	18 3/4 (476.25)	3/4 (19.05)	3800 (16.90)	22.55 (10.23)					
12 (300)	3 (76.20)	9 (228.60)	2 1/2 (63.50)	15 1/4 (387.35)	19 3/4 (501.65)	7/8 (22.23)	3800 (16.90)	26.10 (11.84)					
14 (350)	4 (101.60)	11 3/4 (298.45)	3 (76.20)	17 1/2 (444.50)	22 (558.80)	7/8 (22.23)	5300 (23.58)	41.65 (18.89)					
16 (400)	4 (101.60)	12 3/4 (323.85)	3 (76.20)	18 1/2 (469.90)	23 (584.20)	7/8 (22.23)	5300 (23.58)	44.10 (20.00)					
18 (450)	6 (152.40)	15 (381.00)	4 (101.60)	20 3/4 (527.05)	25 1/4 (641.35)	1 (25.40)	6700 (29.80)	70.90 (32.16)					
20 (500)	6 (152.40)	16 (406.40)	4 (101.60)	21 3/4 (552.45)	26 1/4 (666.75)	1 (25.40)	6700 (29.80)	73.75 (33.45)					
24 (600)	6 (152.40)	18 1/2 (469.90)	4 (101.60)	24 1/4 (615.95)	28 3/4 (730.25)	1 (25.40)	7300 (32.47)	91.60 (41.55)					
30 (750)	6 (152.40)	21 (533.40)	4 (101.60)	26 3/4 (679.45)	31 1/4 (793.75)	1 (25.40)	7300 (32.47)	106.55 (48.33)					
36 (900)	6 (152.40)	24 (609.60)	4 (101.60)	29 3/4 (755.65)	34 1/4 (869.95)	1 (25.40)	7300 (32.47)	112.50 (51.03)					

**FIG. 877**

## PIPE SUPPORT ADJUSTER

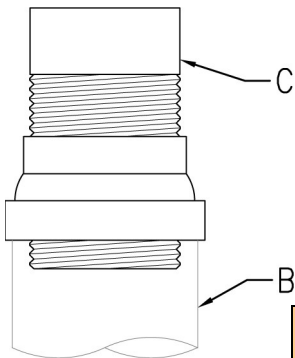

- Function:** Designed to provide up to 4 1/2" (114.3) of vertical adjustment after installation. Normally used in conjunction with Fig. 871 threaded base stand, Fig. 880 pipe saddle support or Fig. 882 pipe saddle support with U-bolt.
- Material:** Carbon steel with malleable iron reducer
- Finish:** Plain or electro-galvanized
- Approvals:** Complies with Federal Specification A-A-1192A (Type 38) and Manufacturers' Standardization Society ANSI/MSS SP-58 (Type 38) which supersedes ANSI/MSS SP-69. (When used with Fig. 880 or Fig. 882)
- Ordering:** Specify figure number, pipe size, and finish.

Adjuster Size	For Pipe Size	B	C	Max. Adjustment	Wt. Each	
					lbs.	kg
1 1/2 (38.10)	2 1/2 to 3 1/2 (65 to 90)	2 1/2	1 1/2	4 1/2 (114.30)	4.05	(1.84)
2 1/2 (63.50)	4 to 12 (100 to 300)	3	2 1/2	4 1/2 (114.30)	8.30	(3.76)
3 (76.20)	14 to 16 (350 to 400)	4	3	4 1/2 (114.30)	12.60	(5.72)
4 (101.60)	18 to 36 (450 to 900)	6	4	4 1/2 (114.30)	22.60	(10.25)

Unless otherwise specified, all dimensions on drawings and in charts are in inches and dimensions shown in parentheses are in millimeters.

# PIPE SUPPORTS



## PIPE SUPPORT ADJUSTERS FIG. 878 & 879

**Function:** Designed to provide up to 4<sup>1</sup>/<sub>2</sub>" (114.3) of vertical adjustment after installation.  
**Material:** Carbon steel with malleable iron reducer  
**Finish:** Plain or electro-galvanized  
**Ordering:** Specify figure number, pipe size, height to center of pipe, and finish.

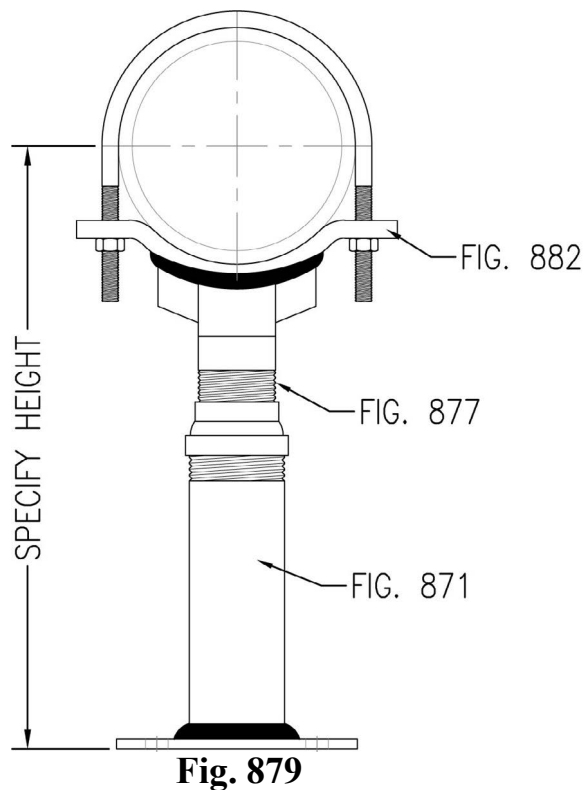
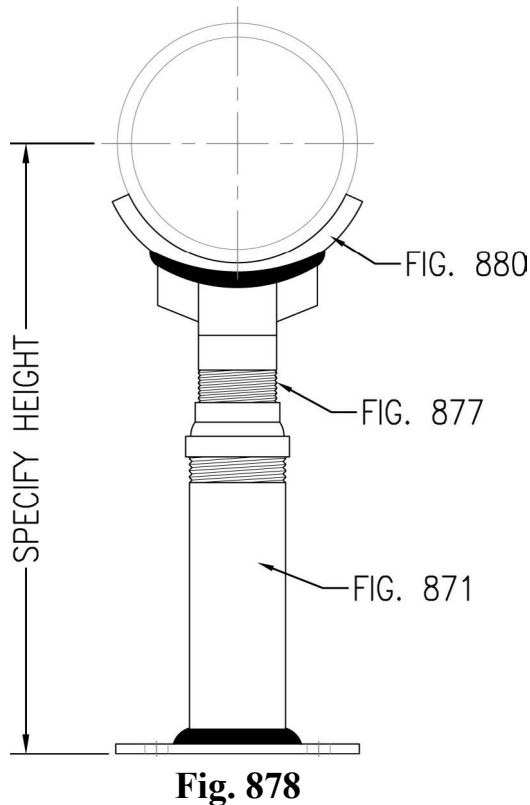

- THREADED ACCESSORIES
- CPVC STRAPS
- BAND HANGERS
- BEAM CLAMPS
- CLEVIS HANGERS
- PIPE ROLLER SUPPORTS
- SPLIT RING HANGERS
- PIPE CLAMPS
- CENTER LOAD BEAM CLAMPS
- PIPE SHIELDS, INSULATION, & SADDLES
- PIPE GUIDES & SLIDES
- WALL BRACKETS
- PIPE SUPPORTS
- STRUCTURAL ATTACHMENTS
- SEISMIC BRACING

Unless otherwise specified, all dimensions on drawings and in charts are in inches and dimensions shown in parentheses are in millimeters.

# PIPE SUPPORTS

**FIG. 880**

## PIPE SADDLE SUPPORT

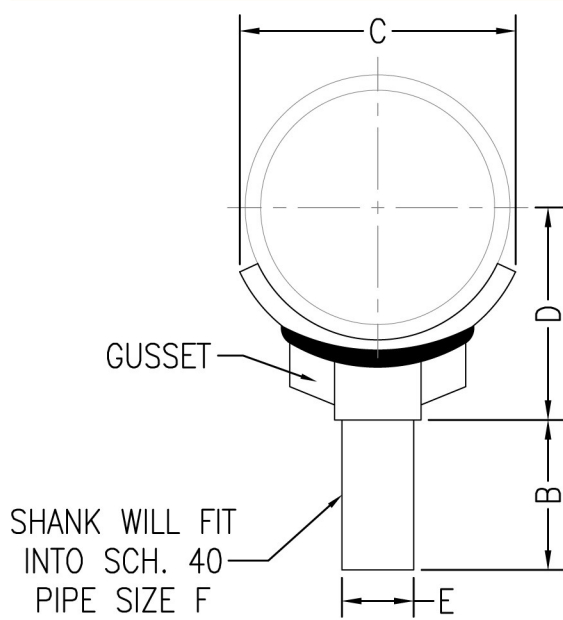

- Function:** Designed to support horizontal pipe running close to the floor. Normally used in conjunction with floor stanchions.
- Material:** Carbon steel (Type 304 or 316 Stainless Steel upon request)
- Finish:** Plain or electro-galvanized (Hot dipped galvanized upon request)
- Approvals:** Complies with Federal Specification A-A-1192A (Type 36) and Manufacturers' Standardization Society ANSI/MSS SP-58 (Type 36) which supersedes ANSI/MSS SP-69.
- Ordering:** Specify figure number, pipe size, material, and finish.

*NOTE: Gussets furnished on 8" (200) and larger.*

Pipe Size		B		C		D		E		Pipe size F		Max. Rec. Load		Wt. Each	
												lbs.	kN	lbs.	kg
2½	(65)	4	(101.6)	2½	(63.50)	3 <sup>11</sup> / <sub>16</sub>	(93.66)	1½	(38.10)	1½	(40)	1800	(8.01)	1.67	(.76)
3	(80)	4	(101.6)	3 <sup>1</sup> / <sub>32</sub>	(76.99)	4	(101.60)	1½	(38.10)	1½	(40)	1800	(8.01)	1.76	(.80)
3½	(90)	4	(101.6)	3 <sup>7</sup> / <sub>16</sub>	(87.31)	4¼	(107.95)	1½	(38.10)	1½	(40)	1800	(8.01)	1.88	(.85)
4	(100)	4	(101.6)	4¼	(107.95)	4½	(114.30)	2 <sup>3</sup> / <sub>8</sub>	(60.33)	2½	(65)	3800	(16.90)	3.60	(1.63)
5	(125)	4	(101.6)	4 <sup>13</sup> / <sub>16</sub>	(122.24)	5 <sup>1</sup> / <sub>16</sub>	(128.59)	2 <sup>3</sup> / <sub>8</sub>	(60.33)	2½	(65)	3800	(16.90)	3.81	(1.73)
6	(150)	4	(101.6)	6 <sup>1</sup> / <sub>16</sub>	(153.99)	5 <sup>11</sup> / <sub>16</sub>	(144.46)	2 <sup>3</sup> / <sub>8</sub>	(60.33)	2½	(65)	3800	(16.90)	5.50	(2.49)
8	(200)	4	(101.6)	7 <sup>15</sup> / <sub>16</sub>	(201.61)	6 <sup>11</sup> / <sub>16</sub>	(169.86)	2 <sup>3</sup> / <sub>8</sub>	(60.33)	2½	(65)	3800	(16.90)	7.00	(3.18)
10	(250)	4	(101.6)	9 <sup>5</sup> / <sub>8</sub>	(244.48)	7 <sup>7</sup> / <sub>8</sub>	(200.03)	2 <sup>3</sup> / <sub>8</sub>	(60.33)	2½	(65)	3800	(16.90)	7.66	(3.47)
12	(300)	4	(101.6)	11 <sup>11</sup> / <sub>16</sub>	(296.86)	8 <sup>7</sup> / <sub>8</sub>	(225.43)	2 <sup>3</sup> / <sub>8</sub>	(60.33)	2½	(65)	3800	(16.90)	8.95	(4.06)
14	(350)	4	(101.6)	12 <sup>1</sup> / <sub>8</sub>	(307.98)	11 <sup>5</sup> / <sub>8</sub>	(295.28)	2 <sup>7</sup> / <sub>8</sub>	(73.03)	3	(80)	5300	(23.58)	16.54	(7.50)
16	(400)	4	(101.6)	13 <sup>7</sup> / <sub>8</sub>	(352.43)	12 <sup>5</sup> / <sub>8</sub>	(320.68)	2 <sup>7</sup> / <sub>8</sub>	(73.03)	3	(80)	5300	(23.58)	18.70	(8.48)
18	(450)	4	(101.6)	15 <sup>19</sup> / <sub>32</sub>	(396.08)	14 <sup>3</sup> / <sub>4</sub>	(374.65)	4	(101.60)	4	(100)	6700	(29.80)	27.98	(12.69)
20	(500)	4	(101.6)	17 <sup>5</sup> / <sub>16</sub>	(439.74)	15 <sup>3</sup> / <sub>4</sub>	(400.05)	4	(101.60)	4	(100)	6700	(29.80)	30.20	(13.70)
24	(600)	4	(101.6)	20 <sup>25</sup> / <sub>32</sub>	(527.84)	18	(457.20)	4	(101.60)	4	(100)	7300	(32.47)	41.46	(18.81)
30	(750)	4	(101.6)	26	(660.40)	21	(533.40)	4	(101.60)	4	(100)	7300	(32.47)	76.24	(34.58)
36	(900)	4	(101.6)	31 <sup>3</sup> / <sub>16</sub>	(792.16)	24	(609.60)	4	(101.60)	4	(100)	7300	(32.47)	88.77	(40.27)

Unless otherwise specified, all dimensions on drawings and in charts are in inches and dimensions shown in parentheses are in millimeters.

# PIPE SUPPORTS



## PIPE SADDLE SUPPORT WITH U-BOLT

**FIG. 882**

- Function:** Designed to support horizontal pipe running close to the floor. The U-bolt securely holds the pipe to the saddle.
- Material:** Carbon steel (Type 304 or 316 Stainless Steel upon request)
- Finish:** Plain or electro-galvanized (Hot dipped galvanized with electro-galvanized hardware upon request)
- Approvals:** Complies with Federal Specification A-A-1192A (Type 37) and Manufacturers' Standardization Society ANSI/MSS SP-58 (Type 37) which supersedes ANSI/MSS SP-69.
- Ordering:** Specify figure number, pipe size, material, and finish.

*NOTE: Gussets furnished on 8" (200) and larger.*

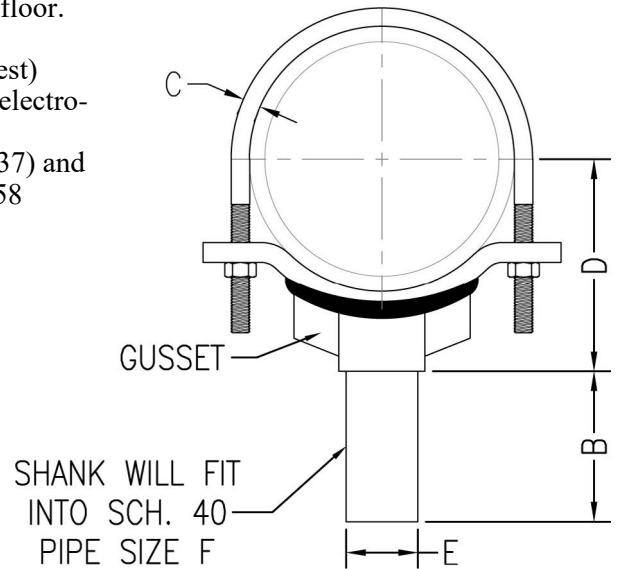

Pipe Size		B		C		D		E		Pipe size F		Max. Rec. Load		Wt. Each	
												lbs.	kN	lbs.	kg
2½	(65)	4	(101.6)	½	(12.70)	3 <sup>11</sup> / <sub>16</sub>	(93.66)	1½	(38.10)	1½	(40)	1800	(8.01)	4.85	(2.20)
3	(80)	4	(101.6)	½	(12.70)	4	(101.60)	1½	(38.10)	1½	(40)	1800	(8.01)	5.00	(2.27)
3½	(90)	4	(101.6)	½	(12.70)	4¼	(107.95)	1½	(38.10)	1½	(40)	1800	(8.01)	5.20	(2.36)
4	(100)	4	(101.6)	½	(12.70)	4½	(114.30)	2 <sup>3</sup> / <sub>8</sub>	(60.33)	2½	(65)	3800	(16.90)	4.95	(2.25)
5	(125)	4	(101.6)	½	(12.70)	5 <sup>1</sup> / <sub>16</sub>	(128.59)	2 <sup>3</sup> / <sub>8</sub>	(60.33)	2½	(65)	3800	(16.90)	5.15	(2.34)
6	(150)	4	(101.6)	5/8	(15.88)	5 <sup>11</sup> / <sub>16</sub>	(144.46)	2 <sup>3</sup> / <sub>8</sub>	(60.33)	2½	(65)	3800	(16.90)	7.95	(3.61)
8	(200)	4	(101.6)	5/8	(15.88)	6 <sup>11</sup> / <sub>16</sub>	(169.86)	2 <sup>3</sup> / <sub>8</sub>	(60.33)	2½	(65)	3800	(16.90)	9.65	(4.38)
10	(250)	4	(101.6)	¾	(19.05)	8	(203.20)	2 <sup>3</sup> / <sub>8</sub>	(60.33)	2½	(65)	3800	(16.90)	14.25	(6.46)
12	(300)	4	(101.6)	7/8	(22.23)	9	(228.60)	2 <sup>3</sup> / <sub>8</sub>	(60.33)	2½	(65)	3800	(16.90)	17.80	(8.07)
14	(350)	4	(101.6)	7/8	(22.23)	11¾	(298.45)	2 <sup>7</sup> / <sub>8</sub>	(73.03)	3	(80)	5300	(23.58)	29.05	(13.18)
16	(400)	4	(101.6)	7/8	(22.23)	12¾	(323.85)	2 <sup>7</sup> / <sub>8</sub>	(73.03)	3	(80)	5300	(23.58)	31.50	(14.29)
18	(450)	4	(101.6)	1	(25.40)	15	(381.00)	4	(101.60)	4	(100)	6700	(29.80)	48.30	(21.91)
20	(500)	4	(101.6)	1	(25.40)	16	(406.40)	4	(101.60)	4	(100)	6700	(29.80)	53.15	(24.11)
24	(600)	4	(101.6)	1	(25.40)	18½	(469.90)	4	(101.60)	4	(100)	7300	(32.47)	69.00	(31.30)
30	(750)	4	(101.6)	1	(25.40)	21	(533.40)	4	(101.60)	4	(100)	7300	(32.47)	83.95	(38.08)
36	(900)	4	(101.6)	1	(25.40)	24	(609.60)	4	(101.60)	4	(100)	7300	(32.47)	96.50	(43.77)

Unless otherwise specified, all dimensions on drawings and in charts are in inches and dimensions shown in parentheses are in millimeters.

# PIPE SUPPORTS

**FIG. 883**

## PIPE FLANGE SUPPORT

**Function:** Designed to support 125 lb. cast iron and 150 lb. forged steel flanged connections. (Consult factory for other flanged bolt patterns). To complete floor stanchion, use fig. 871 threaded base stand. For complete floor stanchion with vertical adjustment, use fig. 877 pipe support adjuster and fig. 871 threaded base stand.

**Material:** Carbon steel

**Finish:** Plain or electro-galvanized

**Ordering:** Specify figure number, pipe size, and finish.

*NOTE: Gussets furnished on 8" (200) and larger.*

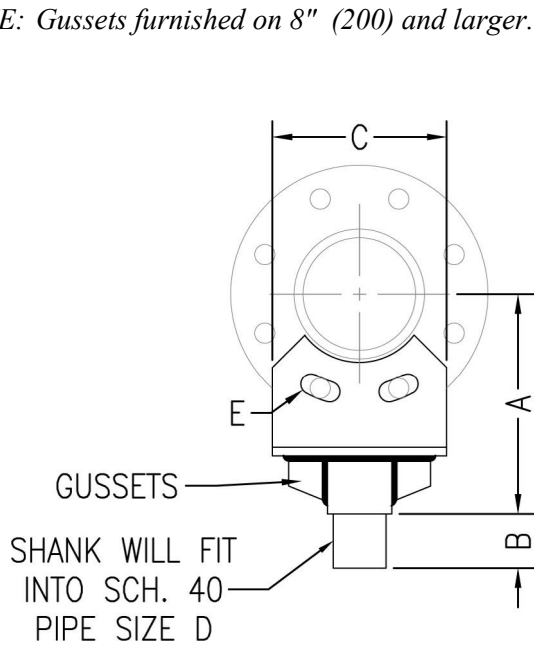

For pipe sizes 2" (50) through 12" (300)

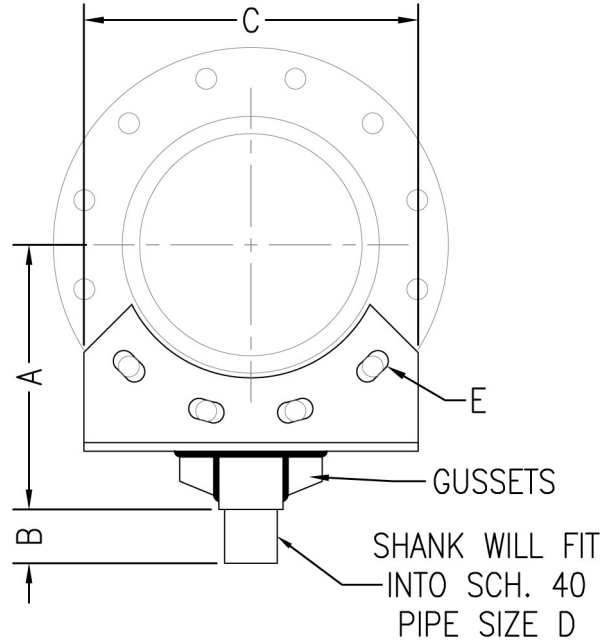

For pipe sizes 14" (350) through 24" (600)

Pipe Size		A		B		C		D		E		Wt. Each	
		in	mm	in	mm	in	mm	in	mm	in	mm	lbs.	kg
2	(50)	5 1/2	(139.7)	4	(101.6)	5 1/4	(133.4)	1 1/2	(40)	3/4	(19.1)	3.06	(1.4)
2 1/2	(65)	6	(152.4)	4	(101.6)	6	(152.4)	1 1/2	(40)	3/4	(19.1)	3.43	(1.6)
3	(80)	6 1/4	(158.75)	4	(101.6)	6 1/4	(158.8)	1 1/2	(40)	3/4	(19.1)	3.51	(1.6)
3 1/2	(90)	6 3/4	(171.45)	4	(101.6)	6	(152.4)	1 1/2	(40)	3/4	(19.1)	3.32	(1.5)
4	(100)	7	(177.8)	4	(101.6)	6 3/8	(161.9)	2 1/2	(65)	3/4	(19.1)	5.21	(2.4)
5	(125)	7 1/2	(190.5)	4	(101.6)	7 1/16	(179.4)	2 1/2	(65)	7/8	(22.2)	5.50	(2.5)
6	(150)	8 1/4	(209.55)	4	(101.6)	7 3/4	(196.9)	2 1/2	(65)	7/8	(22.2)	7.57	(3.4)
8	(200)	9 1/2	(241.3)	4	(101.6)	9 9/16	(242.9)	2 1/2	(65)	7/8	(22.2)	9.25	(4.2)
10	(250)	10 3/4	(273.05)	4	(101.6)	8	(203.2)	2 1/2	(65)	1	(25.4)	8.11	(3.7)
12	(300)	12 1/4	(311.15)	4	(101.6)	9 1/2	(241.3)	2 1/2	(65)	1	(25.4)	9.63	(4.4)
14	(350)	15 1/4	(387.35)	4	(101.6)	18 3/16	(462.0)	3	(80)	1 1/8	(28.6)	23.50	(10.7)
16	(400)	16 1/2	(419.1)	4	(101.6)	16 5/8	(422.3)	3	(80)	1 1/8	(28.6)	22.10	(10.0)
18	(450)	18 1/2	(469.9)	4	(101.6)	17 11/16	(449.3)	4	(100)	1 1/4	(31.8)	36.26	(16.5)
20	(500)	19 3/4	(501.65)	4	(101.6)	15 3/4	(400.1)	4	(100)	1 1/4	(31.8)	33.34	(15.1)
24	(600)	22	(558.8)	4	(101.6)	18 3/8	(466.7)	4	(100)	1 3/8	(34.9)	37.95	(17.2)



# STRUCTURAL ATTACHMENTS



## ADJUSTABLE Q-DECK INSERT FIG. 885

**Function:** Designed for installation in metal concrete deck forms to provide a means to support piping and equipment.

**Material:** Carbon steel

**Finish:** Plain or electro-galvanized

**Ordering:** Specify figure number, rod size, and finish.

*NOTE: Based on the rod diameter only. Rating is subject to the conditions that the concrete used is of sufficient strength to hold the deck hanger.*

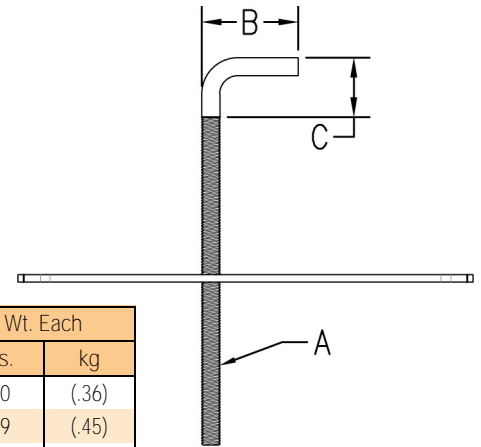

Rod Size A	B		Thread Length		C		Max. Rec. Load		Wt. Each	
							lbs.	kN	lbs.	kg
3/8	1 11/16	(42.86)	7	(177.8)	1	(25.4)	730	(3.25)	.80	(.36)
1/2	1 3/4	(44.45)	7	(177.8)	1	(25.4)	1350	(6.01)	.99	(.45)
5/8	2 5/16	(58.74)	7	(177.8)	1	(25.4)	2160	(9.61)	1.29	(.59)
3/4	2 3/8	(60.33)	7	(177.8)	1	(25.4)	3230	(14.37)	2.38	(1.08)
7/8	2 3/8	(60.33)	7	(177.8)	1	(25.4)	4480	(19.93)	2.84	(1.29)
1	2 3/8	(60.33)	7	(177.8)	1	(25.4)	5900	(26.24)	2.97	(1.35)

- THREADED ACCESSORIES
- CPVC STRAPS
- BAND HANGERS
- BEAM CLAMPS
- CLEVIS HANGERS
- PIPE ROLLER SUPPORTS
- SPLIT RING HANGERS
- PIPE CLAMPS
- CENTER LOAD BEAM CLAMPS
- PIPE SHIELDS, INSULATION, & SADDLES
- PIPE GUIDES & SLIDES
- WALL BRACKETS
- PIPE SUPPORTS
- STRUCTURAL ATTACHMENTS
- SEISMIC BRACING

Unless otherwise specified, all dimensions on drawings and in charts are in inches and dimensions shown in parentheses are in millimeters.

## FIG. 900 & 900-1

## WELDED BEAM ATTACHMENT

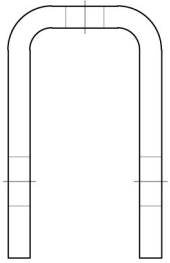

**Fig. 900-1**  
Without Bolt  
& Nut

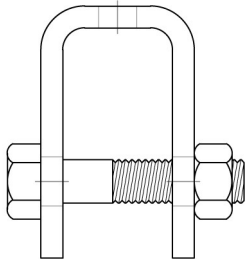

**Fig. 900**  
With Bolt  
& Nut

**Function:** Designed for attaching hanger rod to the bottom flange of a beam. If installed in the inverted position, the hanger rod can be vertically adjusted otherwise bolt and nut are required.

**Material:** Carbon steel (Type 304 or 316 Stainless Steel upon request)

**Finish:** Plain or electro-galvanized (Hot dipped galvanized with electro-galvanized hardware upon request)

**Approvals:** Complies with Federal Specification A-A-1192A (Type 22) and Manufacturers' Standardization Society ANSI/MSS SP-58 (Type 22) which supersedes ANSI/MSS SP-69.

**Ordering:** Specify figure number, rod size, material, and finish.

**NOTE:** The 1" size and larger are furnished with pin and cotter on Fig. 900.

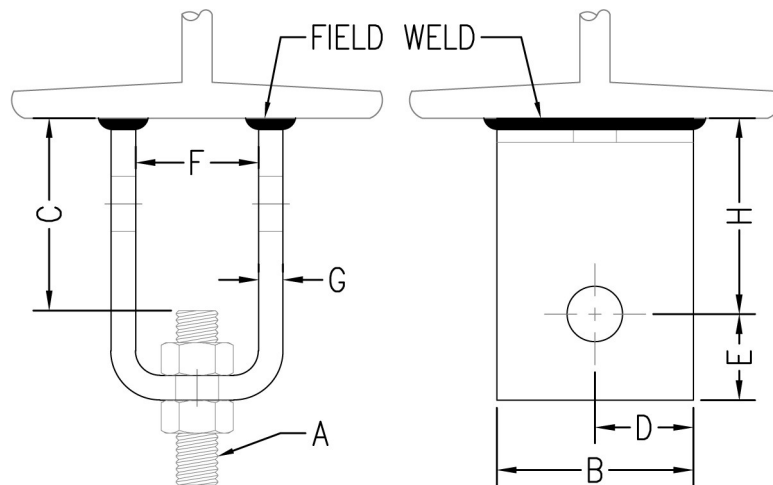
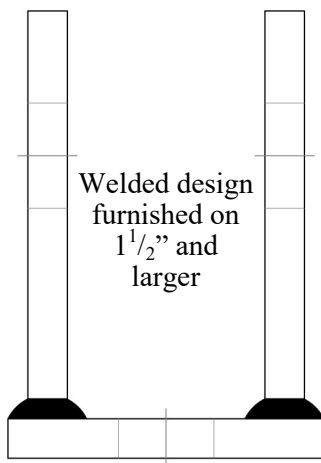

Rod Size A	B		C		D		E		F		G	
3/8	2	(50.80)	1 7/8	(47.63)	1	(25.40)	7/8	(22.23)	1 1/4	(31.75)	3 ga.	--
1/2	2	(50.80)	1 3/4	(44.45)	1	(25.40)	7/8	(22.23)	1 1/4	(31.75)	3 ga.	--
5/8	2	(50.80)	1 3/4	(44.45)	1	(25.40)	7/8	(22.23)	1 1/4	(31.75)	3 ga.	--
3/4	2 1/2	(63.50)	2	(50.80)	1 1/4	(31.75)	1 1/4	(31.75)	2 1/4	(57.15)	3/8	(9.53)
7/8	2 1/2	(63.50)	3	(76.20)	1 1/4	(31.75)	1 1/4	(31.75)	2 3/8	(60.33)	3/8	(9.53)
1	3	(76.20)	3	(76.20)	1 1/2	(38.10)	1 1/2	(38.10)	2 3/4	(69.85)	1/2	(12.70)
1 1/8	3	(76.20)	3	(76.20)	1 1/2	(38.10)	1 3/4	(44.45)	3	(76.20)	1/2	(12.70)
1 1/4	4	(101.60)	3 1/2	(88.90)	2	(50.80)	2	(50.80)	3 1/2	(88.90)	5/8	(15.88)
1 1/2	5	(127.00)	4	(101.60)	2 1/2	(63.50)	2 1/2	(63.50)	3	(76.20)	3/4	(19.05)
1 3/4	5	(127.00)	5	(127.00)	2 1/2	(63.50)	2 3/4	(69.85)	3 3/4	(95.25)	3/4	(19.05)
2	6	(152.40)	5 1/4	(133.35)	3	(76.20)	3 1/4	(82.55)	3 3/4	(95.25)	3/4	(19.05)

Rod Size A	H		Bolt or Pin Size	Max. Rec. Load				Wt. Each			
				650°F (343°C)		750°F (399°C)		Fig. 900-1		Fig. 900	
				lbs.	kN	lbs.	kN	lbs.	kg	lbs.	kg
3/8	2	(50.80)	1/2 x 2 1/2	730	(3.25)	572	(2.54)	.87	(.39)	1.13	(.51)
1/2	2	(50.80)	5/8 x 2 1/2	1350	(6.01)	1057	(4.70)	.85	(.39)	1.28	(.58)
5/8	2	(50.80)	3/4 x 2 1/2	2160	(9.61)	1692	(7.52)	.84	(.38)	1.50	(.68)
3/4	2	(50.80)	7/8 x 4	3230	(14.37)	2530	(11.25)	2.00	(.91)	3.04	(1.38)
7/8	3	(76.20)	1 x 4 1/2	4480	(19.93)	3508	(15.61)	2.50	(1.13)	4.02	(1.82)
1	3	(76.20)	1 1/8 x 5	5900	(26.24)	4620	(20.55)	4.14	(1.88)	6.30	(2.86)
1 1/8	3	(76.20)	1 1/4 x 5	7450	(33.14)	5834	(25.95)	4.37	(1.98)	7.15	(3.24)
1 1/4	3	(76.20)	1 3/8 x 6 1/2	9500	(42.26)	7440	(33.09)	8.50	(3.86)	12.62	(5.72)
1 1/2	4	(101.60)	1 5/8 x 6	13800	(61.39)	10807	(48.07)	16.41	(7.44)	23.23	(10.54)
1 3/4	5	(127.00)	1 7/8 x 7	18600	(82.74)	14566	(64.79)	18.70	(8.48)	24.20	(10.98)
2	5	(127.00)	2 1/4 x 7	24600	(109.43)	19265	(85.70)	22.80	(10.34)	30.60	(13.88)

Unless otherwise specified, all dimensions on drawings and in charts are in inches and dimensions shown in parentheses are in millimeters.

# STRUCTURAL ATTACHMENTS



## CONCRETE ROD ATTACHMENT PLATE

**FIG. 903**

- Function:** Designed for attaching hanger rod to a concrete ceiling.
- Material:** Carbon steel (Type 304 or 316 Stainless Steel upon request)
- Finish:** Plain or electro-galvanized (Hot dipped galvanized upon request)
- Ordering:** Specify figure number, rod size, material, and finish.

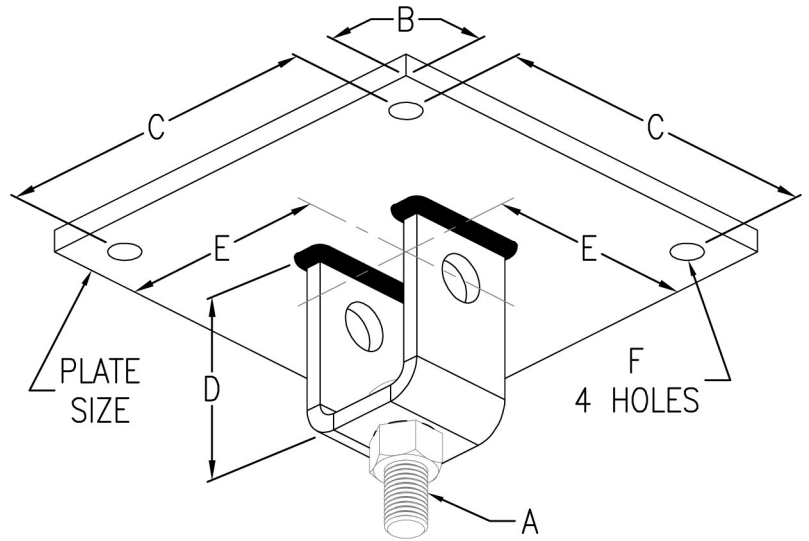

Rod Size A		B		C		D		E		F		Plate Size		Max. Rec. Load		Wt. Each	
			(mm)		(mm)		(mm)		(mm)		(mm)		(mm)	lbs.	kN	lbs.	kg
3/8	1	(25.40)	8	(203.20)	2 7/8	(73.03)	5	(127.00)	9/16	(14.29)	10 x 10 x 3/8	(254 x 254 x 9.53)	730	(3.25)	11.60	(5.26)	
1/2	1	(25.40)	8	(203.20)	2 7/8	(73.03)	5	(127.00)	9/16	(14.29)	10 x 10 x 3/8	(254 x 254 x 9.53)	1350	(6.01)	11.60	(5.26)	
5/8	1	(25.40)	8	(203.20)	2 7/8	(73.03)	5	(127.00)	9/16	(14.29)	10 x 10 x 3/8	(254 x 254 x 9.53)	2160	(9.61)	15.10	(6.85)	
3/4	1	(25.40)	8	(203.20)	3 1/4	(82.55)	5	(127.00)	1 1/16	(17.46)	10 x 10 x 1/2	(254 x 254 x 12.7)	3230	(14.37)	16.10	(7.30)	
7/8	1	(25.40)	8	(203.20)	4 1/4	(107.95)	5	(127.00)	1 1/16	(17.46)	10 x 10 x 1/2	(254 x 254 x 12.7)	4480	(19.93)	16.70	(7.57)	
1	2	(50.80)	8	(203.20)	4 1/2	(114.30)	6	(152.40)	1 3/16	(20.64)	12 x 12 x 1/2	(304.8 x 304.8 x 12.7)	5900	(26.24)	34.90	(15.83)	
1 1/8	2	(50.80)	8	(203.20)	4 3/4	(120.65)	6	(152.40)	1 3/16	(20.64)	12 x 12 x 1/2	(304.8 x 304.8 x 12.7)	7450	(33.14)	35.25	(15.99)	
1 1/4	2	(50.80)	8	(203.20)	5	(127.00)	6	(152.40)	1 5/16	(23.81)	12 x 12 x 3/4	(304.8 x 304.8 x 19.05)	9500	(42.26)	38.70	(17.55)	
1 1/2	2	(50.80)	8	(203.20)	6 1/2	(165.10)	6	(152.40)	1 1/16	(26.99)	12 x 12 x 1	(304.8 x 304.8 x 25.4)	13800	(61.39)	56.40	(25.58)	
1 3/4	2	(50.80)	10	(254.00)	7 3/4	(196.85)	7	(177.80)	1 3/8	(34.93)	14 x 14 x 1 1/4	(355.6 x 355.6 x 31.75)	18600	(82.74)	88.10	(39.96)	
2	2	(50.80)	10	(254.00)	8 1/4	(209.55)	7	(177.80)	1 3/8	(34.93)	14 x 14 x 1 1/4	(355.6 x 355.6 x 31.75)	24600	(109.43)	92.20	(41.82)	

Unless otherwise specified, all dimensions on drawings and in charts are in inches and dimensions shown in parentheses are in millimeters.

- THREADED ACCESSORIES
- CPVC STRAPS
- BAND HANGERS
- BEAM CLAMPS
- CLEVIS HANGERS
- PIPE ROLLER SUPPORTS
- SPLIT RING HANGERS
- PIPE CLAMPS
- CENTER LOAD BEAM CLAMPS
- PIPE SHIELDS, INSULATION, & SADDLES
- PIPE GUIDES & SLIDES
- WALL BRACKETS
- PIPE SUPPORTS
- STRUCTURAL ATTACHMENTS
- SEISMIC BRACING

**FIG. 904**

## CONCRETE CLEVIS PLATE

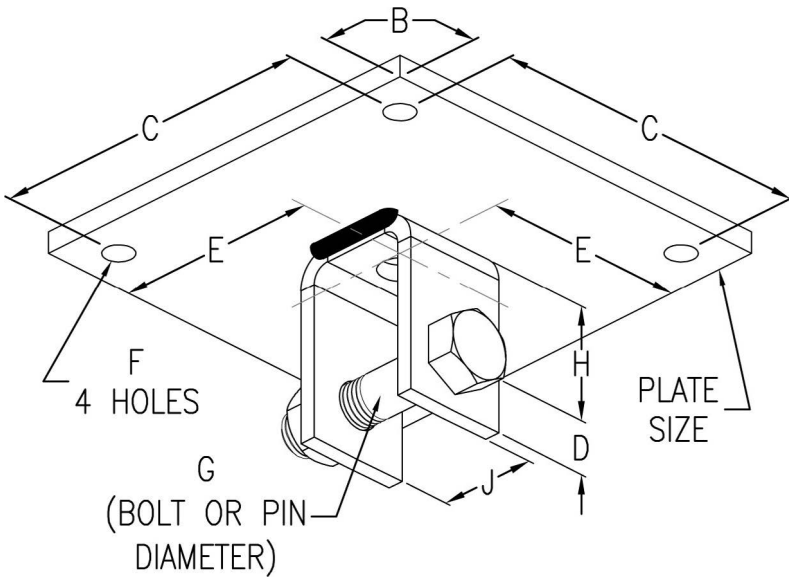

**Function:** Designed for use as a structural attachment to a concrete ceiling. Normally used in conjunction with Fig. 35 weldless eye nut or Fig. 55 welded eye rod.

**Material:** Carbon steel (Type 304 or 316 Stainless Steel upon request)

**Finish:** Plain or electro-galvanized (Hot dipped galvanized with electro-galvanized hardware upon request)

**Ordering:** Specify figure number, rod size, material, and finish.

**NOTE:** The 1" size and larger are furnished with pin and cotter. All other sizes are furnished with bolt and nut.

Rod Size A	B		C		D		E		F		G	
3/8	1	(25.40)	8	(203.20)	7/8	(22.23)	5	(127.00)	9/16	(14.29)	1/2	(12.70)
1/2	1	(25.40)	8	(203.20)	7/8	(22.23)	5	(127.00)	9/16	(14.29)	5/8	(15.88)
5/8	1	(25.40)	8	(203.20)	7/8	(22.23)	5	(127.00)	9/16	(14.29)	3/4	(19.05)
3/4	1	(25.40)	8	(203.20)	1 1/4	(31.75)	5	(127.00)	1 1/16	(17.46)	7/8	(22.23)
7/8	1	(25.40)	8	(203.20)	1 1/4	(31.75)	5	(127.00)	1 1/16	(17.46)	1	(25.40)
1	2	(50.80)	8	(203.20)	1 1/2	(38.10)	6	(152.40)	1 3/16	(20.64)	1 1/8	(28.58)
1 1/8	2	(50.80)	8	(203.20)	1 3/4	(44.45)	6	(152.40)	1 3/16	(20.64)	1 1/4	(31.75)
1 1/4	2	(50.80)	8	(203.20)	2	(50.80)	6	(152.40)	1 5/16	(23.81)	1 3/8	(34.93)
1 1/2	2	(50.80)	8	(203.20)	2 1/2	(63.50)	6	(152.40)	1 1/16	(26.99)	1 5/8	(41.28)
1 3/4	2	(50.80)	10	(254.00)	2 3/4	(69.85)	7	(177.80)	1 3/8	(34.93)	1 7/8	(47.63)
2	2	(50.80)	10	(254.00)	3 1/4	(82.55)	7	(177.80)	1 3/8	(34.93)	2 1/4	(57.15)

Rod Size A	H		J		Plate Size		Max. Rec. Load		Wt. Each	
	lbs.	kg	lbs.	kg	lbs.	kg	lbs.	kg	lbs.	kg
3/8	2	(50.80)	1 1/4	(31.75)	10 x 10 x 3/8	(254 x 254 x 9.53)	730	(3.25)	11.80	(5.35)
1/2	2	(50.80)	1 1/4	(31.75)	10 x 10 x 3/8	(254 x 254 x 9.53)	1350	(6.01)	11.90	(5.40)
5/8	2	(50.80)	1 1/4	(31.75)	10 x 10 x 3/8	(254 x 254 x 9.53)	2160	(9.61)	15.70	(7.12)
3/4	2	(50.80)	2 1/4	(57.15)	10 x 10 x 1/2	(254 x 254 x 12.7)	3230	(14.37)	16.90	(7.67)
7/8	3	(76.20)	2 3/8	(60.33)	10 x 10 x 1/2	(254 x 254 x 12.7)	4480	(19.93)	18.10	(8.21)
1	3	(76.20)	2 3/4	(69.85)	12 x 12 x 1/2	(304.8 x 304.8 x 12.7)	5900	(26.24)	36.90	(16.74)
1 1/8	3	(76.20)	3	(76.20)	12 x 12 x 1/2	(304.8 x 304.8 x 12.7)	7450	(33.14)	37.75	(17.12)
1 1/4	3	(76.20)	3 1/2	(88.90)	12 x 12 x 3/4	(304.8 x 304.8 x 19.05)	9500	(42.26)	40.90	(18.55)
1 1/2	4	(101.60)	3	(76.20)	12 x 12 x 1	(304.8 x 304.8 x 25.4)	13800	(61.39)	59.80	(27.12)
1 3/4	5	(127.00)	3 3/4	(95.25)	14 x 14 x 1 1/4	(355.6 x 355.6 x 31.75)	18600	(82.74)	93.60	(42.46)
2	5	(127.00)	3 3/4	(95.25)	14 x 14 x 1 1/4	(355.6 x 355.6 x 31.75)	24600	(109.43)	100.00	(45.36)

Unless otherwise specified, all dimensions on drawings and in charts are in inches and dimensions shown in parentheses are in millimeters.

## SIDE BEAM CONNECTOR

**FIG. 905**

- Function:** Designed for attaching hanger rod to the side of wooden beams or walls. Normally secured in place with Fig. 48 wood drive screw.
- Material:** Malleable iron
- Finish:** Plain or electro-galvanized
- Approvals:** Complies with Federal Specification A-A-1192A (Type 34) and Manufacturers' Standardization Society ANSI/MSS SP-58 (Type 34) which supersedes ANSI/MSS SP-69.
- Ordering:** Specify figure number, rod size, and finish.

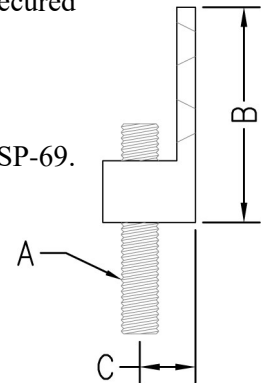

Rod Size A	B		C		Drive Screw Size	Max. Rec. Load		Wt. Each	
						lbs.	kN	lbs.	kg
3/8	2 3/16	(55.56)	9/16	(14.29)	#12 x 1 1/2	250	(1.11)	.13	(.06)
1/2	2 3/4	(69.85)	3/4	(19.05)	#14 x 1 1/2	480	(2.14)	.25	(.11)

## STEEL SIDE BEAM CONNECTOR

**FIG. 906**

- Function:** Designed for attaching hanger rod to wood structures. Secured with Fig. 45 lag screw or two Fig. 48 wood drive screws, see chart.
- Material:** Carbon steel
- Finish:** Plain or electro-galvanized (Hot dipped galvanized upon request)
- Approvals:** Underwriters' Laboratories Listed in the U.S. (UL) and Canada (CUL), and Factory Mutual Approved. Complies with Federal Specification A-A-1192A (Type 34) and Manufacturers' Standardization Society ANSI/MSS SP-58 (Type 34) which supersedes ANSI/MSS SP-69.
- Ordering:** Specify figure number and finish.

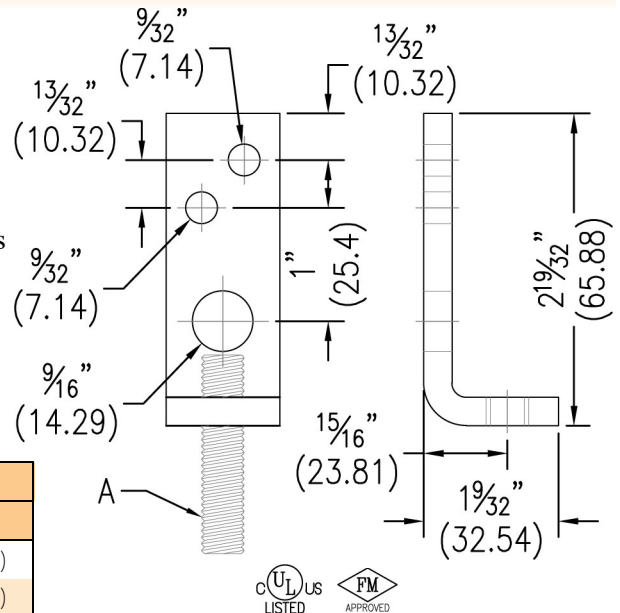

Rod Size A	Max. Pipe Size		UL Listed Fasteners	Max. Rec. Load		Wt. Each	
				lbs.	kN	lbs.	kg
3/8	2	(50)	(2) #16 x 2	400	(1.78)	.21	(.10)
3/8	4	(100)	1/2 x 2 1/2	730	(3.25)	.21	(.10)

## REVERSIBLE ANGLE BRACKET

**FIG. 910**

- Function:** Designed to support pipe at various distances from a wall or column.
- Material:** Carbon steel (Type 304 or 316 Stainless Steel upon request)
- Finish:** Plain or electro-galvanized (Hot dipped galvanized upon request)
- Ordering:** Specify figure number, size number, material, and finish.

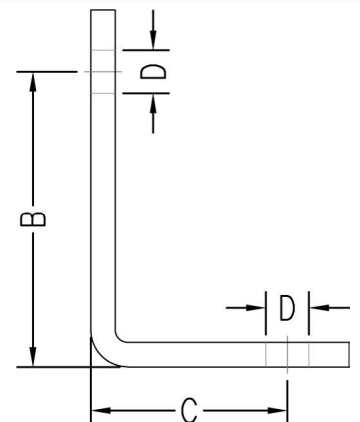

Size No.	B		C		Hole Size D		Max. Rec. Load		Wt. Each	
							lbs.	kN	lbs.	kg
1	3	(76.20)	2	(50.80)	7/16	(11.11)	180	(0.80)	.43	(.20)
2	4	(101.60)	3	(76.20)	7/16	(11.11)	180	(0.80)	.58	(.26)
3	3	(76.20)	2	(50.80)	9/16	(14.29)	390	(1.73)	1.00	(.45)
4	4	(101.60)	3	(76.20)	9/16	(14.29)	390	(1.73)	1.25	(.57)

**FIG. 920**

## SIDE BEAM ANGLE BRACKET

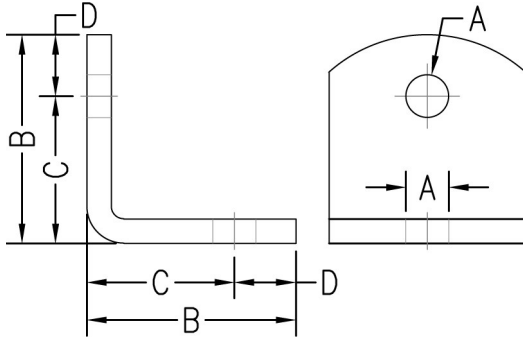

**Function:** Designed for use with wood, concrete, or steel beams to provide a means for supporting hanger rod. When used on steel beams Fig. 920 can be welded or bolted in place.

**Material:** Carbon steel (Type 304 or 316 Stainless Steel upon request)

**Finish:** Plain or electro-galvanized (Hot dipped galvanized upon request)

**Approvals:** Complies with Federal Specification A-A-1192A (Type 34) and Manufacturers' Standardization Society ANSI/MSS SP-58 (Type 34) which supersedes ANSI/MSS SP-69.

**Ordering:** Specify figure number, rod size, material, and finish.

Rod Size A	For Pipe Size		B		C		D		Max. Rec. Load				Wt. Each			
									Lag Screw		Bolted to Steel		lbs.	kg	lbs.	kg
									lbs.	kN	lbs.	kN				
3/8	1 1/2 to 2	(15 to 50)	2 1/8	(53.98)	1 1/2	(38.10)	5/8	(15.88)	390	(1.73)	580	(2.58)	.52	(.24)		
1/2	2 1/2 to 3 1/2	(65 to 90)	2 1/8	(53.98)	1 1/2	(38.10)	5/8	(15.88)	640	(2.85)	960	(4.27)	.50	(.23)		
5/8	4 to 5	(100 to 125)	2 1/2	(63.50)	1 1/2	(38.10)	1	(25.40)	760	(3.38)	1500	(6.67)	.75	(.34)		
3/4	6 to 8	(150 to 200)	2 1/2	(63.50)	1 1/2	(38.10)	1	(25.40)	830	(3.69)	2500	(11.12)	.73	(.33)		
7/8	10 to 12	(250 to 300)	3 1/4	(82.55)	2 1/4	(57.15)	1	(25.40)	830	(3.69)	3600	(16.01)	1.38	(.63)		

**FIG. 925**

## REVERSIBLE SIDE BEAM ANGLE BRACKET

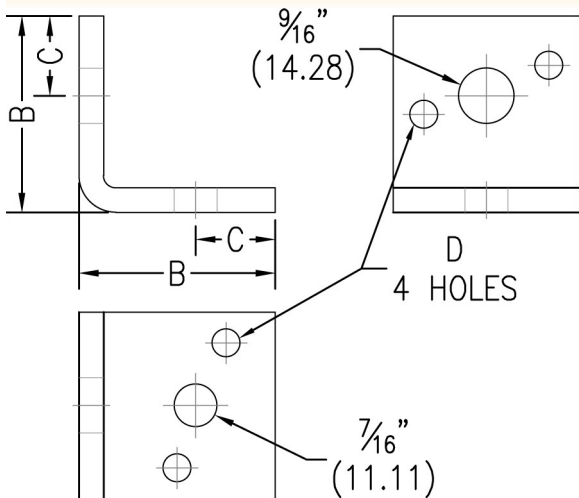

**Function:** Designed for attaching hanger rod to the side of beams or walls. Fig. 925 can accommodate either 3/8" or 1/2" rod.

**Material:** Carbon steel

**Finish:** Plain or electro-galvanized (Hot dipped galvanized upon request)

**Approvals:** Complies with Federal Specification A-A-1192A (Type 34) and Manufacturers' Standardization Society ANSI/MSS SP-58 (Type 34) which supersedes ANSI/MSS SP-69.

**Ordering:** Specify figure number and finish.

For Rod Size	B		C		D		Max. Rec. Load		Wt. Each	
							lbs.	kN	lbs.	kg
3/8 or 1/2	2	(50.80)	1 3/16	(20.64)	9/32	(7.14)	500	(2.22)	.50	(.23)

# STRUCTURAL ATTACHMENTS



## SQUARE PLATE WASHER

**FIG. 930**

- Function:** Designed as a heavy-duty washer to suspend hanger rods.  
**Material:** Carbon steel (Type 304 or 316 Stainless Steel upon request)  
**Finish:** Plain or electro-galvanized (Hot dipped galvanized upon request)  
**Ordering:** Specify figure number, rod size, material, and finish.

Rod Size	A		B		Wt. Each	
					lbs.	kg
3/8	1/4	(6.35)	2	(50.80)	.24	(.11)
1/2	1/4	(6.35)	2	(50.80)	.23	(.10)
5/8	1/4	(6.35)	2 1/2	(63.50)	.40	(.18)
3/4	1/4	(6.35)	2 1/2	(63.50)	.39	(.18)
7/8	3/8	(9.53)	3	(76.20)	.87	(.39)
1	3/8	(9.53)	4	(101.60)	1.60	(.73)
1 1/8	1/2	(12.70)	4	(101.60)	2.26	(1.03)
1 1/4	1/2	(12.70)	5	(127.00)	3.54	(1.61)
1 1/2	3/4	(19.05)	5	(127.00)	4.52	(2.05)
1 3/4	3/4	(19.05)	5	(127.00)	4.38	(1.99)
2	3/4	(19.05)	6	(152.40)	6.80	(3.08)

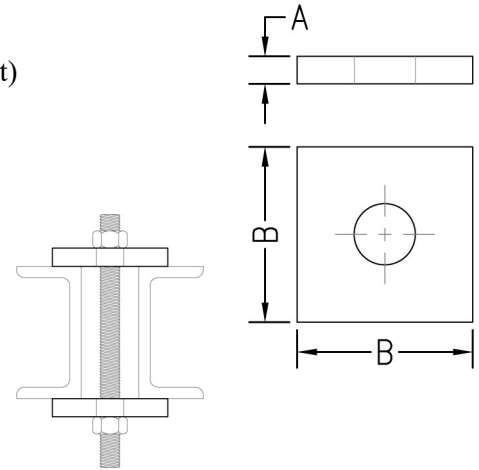

## WELDING LUG

**FIG. 935 & 936**

- Function:** Designed to be welded to the underside of structural members to provide a means of supporting rod attachments. Used in conjunction with Fig. 38 forged steel clevis.  
 Long Welding Lug (**Fig. 935**) or Short Welding Lug (**Fig. 936**)  
**Material:** Carbon steel (Type 304 or 316 Stainless Steel upon request)  
**Finish:** Plain or electro-galvanized (Hot dipped galvanized upon request)  
**Approvals:** Complies with Federal Specification A-A-1192A (Type 57) and Manufacturers' Standardization Society ANSI/MSS SP-58 (Type 57) which supersedes ANSI/MSS SP-69.  
**Ordering:** Specify figure number, rod size, material, and finish.

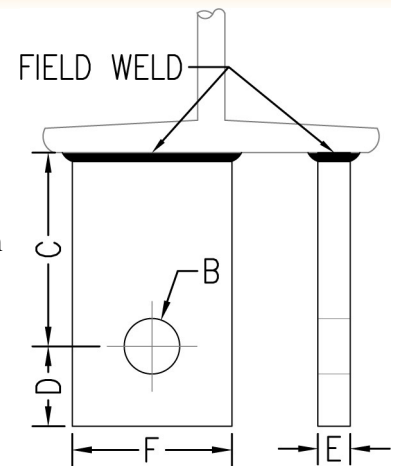

Rod Size	Pin or Bolt	Hole Size B		C				D		E		F		Max. Rec. Load				Wt. Each			
														650°F (343°C)		750°F (399°C)		Fig. 936		Fig. 935	
				lbs.	kN	lbs.	kN	lbs.	kg	lbs.	kg	lbs.	kg	lbs.	kg						
1/2	5/8	11/16	(17.46)	1 1/2	(38.1)	3	(76.2)	1 1/4	(31.75)	1/4	(6.35)	2 1/2	(63.5)	1350	(6.01)	1057	(4.70)	.48	(.22)	.75	(.34)
5/8	3/4	13/16	(20.64)	1 1/2	(38.1)	3	(76.2)	1 1/4	(31.75)	1/4	(6.35)	2 1/2	(63.5)	2160	(9.61)	1692	(7.52)	.41	(.19)	.68	(.31)
3/4	7/8	15/16	(23.81)	1 1/2	(38.1)	3	(76.2)	1 1/4	(31.75)	3/8	(9.53)	2 1/2	(63.5)	3230	(14.37)	2530	(11.25)	.60	(.27)	1.04	(.47)
7/8	1	1 1/8	(28.58)	2	(50.8)	3	(76.2)	1 1/4	(31.75)	3/8	(9.53)	2 1/2	(63.5)	4480	(19.93)	3508	(15.61)	.71	(.32)	.98	(.44)
1	1 1/8	1 1/4	(31.75)	2	(50.8)	3	(76.2)	1 1/2	(38.10)	1/2	(12.70)	3	(76.2)	5900	(26.24)	4620	(20.55)	1.20	(.54)	1.62	(.73)
1 1/4	1 3/8	1 1/2	(38.10)	3	(76.2)	4	(101.6)	2	(50.80)	5/8	(15.88)	4	(101.6)	9500	(42.26)	7440	(33.09)	3.03	(1.37)	3.73	(1.69)
1 1/2	1 5/8	1 3/4	(44.45)	3	(76.2)	4 1/2	(114.3)	2 1/2	(63.50)	3/4	(19.05)	5	(127.0)	13800	(61.39)	10807	(48.07)	4.82	(2.19)	6.42	(2.91)

Unless otherwise specified, all dimensions on drawings and in charts are in inches and dimensions shown in parentheses are in millimeters.

THREADED ACCESSORIES  
 CPVC STRAPS  
 BAND HANGERS  
 BEAM CLAMPS  
 CLEVIS HANGERS  
 PIPE ROLLER SUPPORTS  
 SPLIT RING HANGERS  
 PIPE CLAMPS  
 CENTER LOAD BEAM CLAMPS  
 PIPE SHIELDS, INSULATION, & SADDLES  
 PIPE GUIDES & SLIDES  
 WALL BRACKETS  
 PIPE SUPPORTS  
 STRUCTURAL ATTACHMENTS  
 SEISMIC BRACING

## FIG. 940, 941, & 942

## CEILING FLANGE

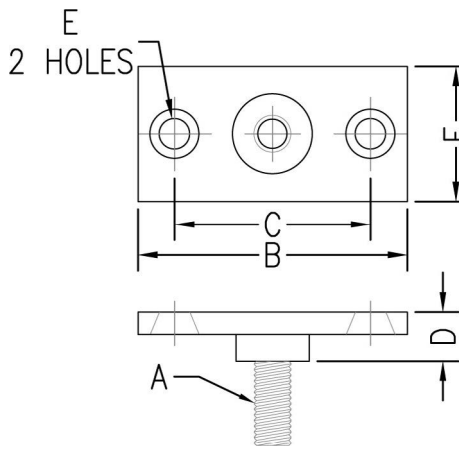

- Function:** Designed to provide a means for attaching hanger rod to wood beams or ceilings.
- Material:** Malleable iron (Type 304 or 316 Stainless Steel upon request for  $\frac{3}{8}$ " only)
- Finish:** Plain (**Fig. 940**), electro-galvanized (**Fig. 941**), or copper color epoxy finish (**Fig. 942**)
- Ordering:** Specify figure number, rod size, material, and finish.

Rod Size A	B		C		D		E		F		Max. Rec. Load		Wt. Each	
	in.	mm	in.	mm	in.	mm	in.	mm	in.	mm	lbs.	kN	lbs.	kg
$\frac{3}{8}$	$2\frac{3}{4}$	(69.85)	2	(50.8)	$\frac{1}{2}$	(12.7)	$\frac{5}{16}$	(7.94)	$1\frac{3}{8}$	(34.93)	180	(0.8)	.18	(.08)
$\frac{1}{2}$	$2\frac{3}{4}$	(69.85)	2	(50.8)	$\frac{1}{2}$	(12.7)	$\frac{5}{16}$	(7.94)	$1\frac{3}{8}$	(34.93)	180	(0.8)	.18	(.08)

\*  $\frac{3}{8}$ " rod sizes are only available in type 304 or 316 stainless steel. For non stainless steel  $\frac{3}{8}$ " rod size, see Fig. 945 (electro-galvanized) or Fig. 946 (copper finish) Steel Ceiling Plate.

## FIG. 945 & 946

## STEEL CEILING PLATE

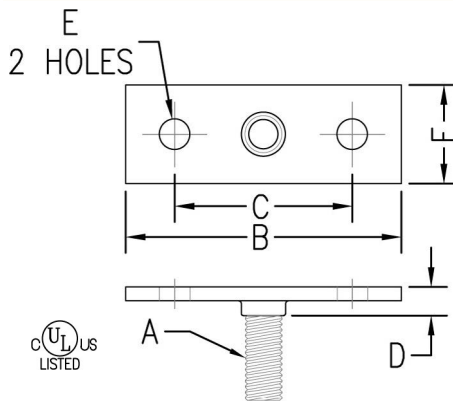

- Function:** Designed to provide a means for attaching hanger rod to wood beams or ceilings. The copper finish is for product identification only and is not intended for corrosion resistance.
- Material:** Carbon steel
- Finish:** Pre-galvanized (**Fig. 945**) or copper finish (**Fig. 946**)
- Approvals:** Underwriters' Laboratories Listed in the U.S. (UL) and Canada (CUL) for supporting up to 2" (50) pipe max. (Fig. 945 only)
- Ordering:** Specify figure number.

Rod Size A	B		C		D		E		F		Max. Rec. Load		Wt. Each	
	in.	mm	in.	mm	in.	mm	in.	mm	in.	mm	lbs.	kN	lbs.	kg
$\frac{3}{8}$	$2\frac{13}{16}$	(71.45)	$1\frac{13}{16}$	(46.05)	$\frac{5}{16}$	(7.94)	$\frac{5}{16}$	(7.94)	1	(25.40)	180	(0.8)	.10	(.05)



## CONCRETE INSERT

## FIG. 950 & 951

**Function:** Designed to be embedded in concrete to provide a means of suspending pipe from ceilings. The insert is held in place by nailing it to the forms, until the concrete is poured. The insert comes with a snap-out plug to keep the inner housing clean during pouring of the concrete. After the concrete has set, the plug is removed, exposing the inner housing. The Fig. 950N and 951N Concrete Insert Nuts can be installed and the rod fastened to the nut. The rod should touch the inside top of the insert but should not be forced to avoid damaging the insert.

**Material:** Carbon steel

**Finish:** Plain (**Fig. 950**) or electro-galvanized (**Fig. 951**)

**Approvals:** Complies with Federal Specification A-A-1192A (Type 18) and Manufacturers' Standardization Society ANSI/MSS SP-58 (Type 18) which supersedes ANSI/MSS SP-69.

**Ordering:** Specify figure number.

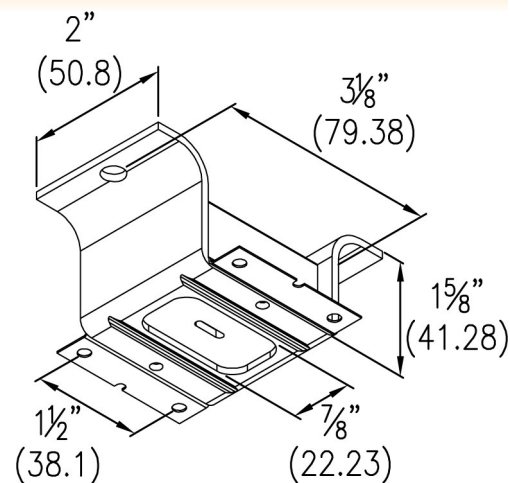

Rod Size	Max. Rec. Load		Wt. Each	
	lbs.	kN	lbs.	kg
1/4	240	(1.07)	.44	(.20)
3/8 - 3/4	600	(2.67)	.44	(.20)

## CONCRETE INSERT NUT

## FIG. 950N & 951N

**Function:** Designed to be used with the Fig. 950 and 951 Concrete Insert.

**Material:** Carbon steel

**Finish:** Plain (**Fig. 950N**) or electro-galvanized (**Fig. 951N**)

**Ordering:** Specify figure number and rod size.

Rod Size	B		Max. Rec. Load		Wt. Each	
			lbs.	kN	lbs.	kg
1/4	1/4	(6.35)	240	(1.07)	.08	(.04)
3/8	3/8	(9.53)	600	(2.67)	.10	(.05)
1/2	1/2	(12.70)	600	(2.67)	.11	(.05)
5/8	1/2	(12.70)	600	(2.67)	.14	(.06)
3/4	1/2	(12.70)	600	(2.67)	.16	(.07)

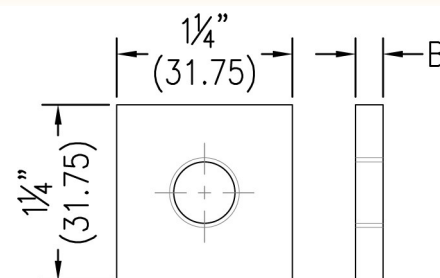

# STRUCTURAL ATTACHMENTS

THREADED ACCESSORIES  
CPVC STRAPS  
BAND HANGERS  
BEAM CLAMPS  
CLEVIS HANGERS  
PIPE ROLLER SUPPORTS  
SPLIT RING HANGERS  
PIPE CLAMPS  
CENTER LOAD BEAM CLAMPS  
PIPE SHIELDS, INSULATION, & SADDLES  
PIPE GUIDES & SLIDES  
WALL BRACKETS  
PIPE SUPPORTS  
STRUCTURAL ATTACHMENTS  
SEISMIC BRACING

## FIG. 990

## ADJUSTABLE IN-RACK FLUE HANGER

- Function:** Designed to be fully adjustable to fit typical 8" (203.2), 10" (254), and 12" (304.8) flue spaces between common warehouse racking types such as teardrop.
- Size:** 3/8" rod
- Material:** Carbon steel
- Finish:** Electro-galvanized
- Install:** Loosen rod coupling so the device can expand. Place compressed product in the rack flue space. Expand device inserting the support rivets into rack columns. Once fully expanded, pull device down securing it into the rack columns ensuring spring clips snap in engaging the rack column. Adjust the rod coupling assembly to the desired position then tighten coupling 80 in.-lbs. (9.04 N-m). Then insert threaded rod until it fully engages into the rod coupling.
- Approvals:** Underwriters' Laboratories Listed in the U.S. (UL) and Canada (CUL).
- Ordering:** Specify figure number.

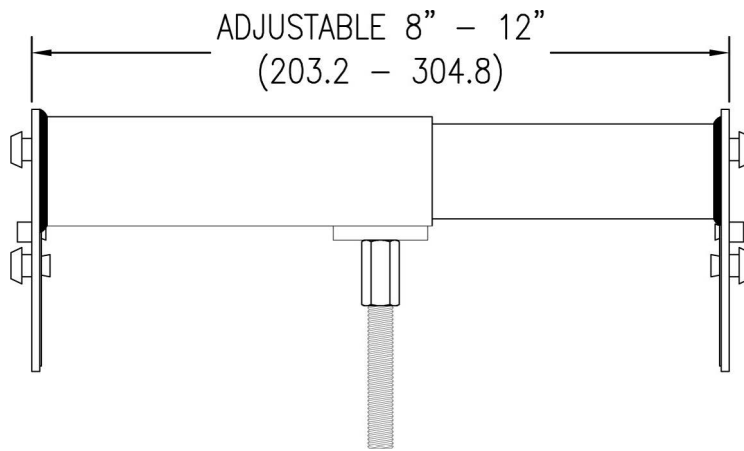
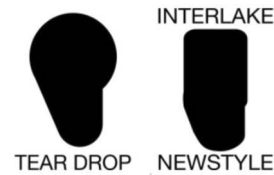

Fig. No.	Flue Space Length		Std. Package	Max. Rec. Load		Wt. Each	
	8 - 12	(203 - 305)		lbs.	kN	lbs.	kg
990	8 - 12	(203 - 305)	5	730	(3.25)	3.50	(1.59)



## FIG. 995

## SINGLE IN-RACK FLUE HANGER

- Function:** Designed to connect to common warehouse racking types such as teardrop.
- Size:** 3/8" rod
- Material:** Carbon steel
- Finish:** Electro-galvanized
- Install:** Insert the support rivets into rack columns. Pull device down securing it into the rack columns ensuring spring clip snaps in engaging the rack column. Adjust the strut nut to the desired position then insert threaded rod until it fully engages into the strut nut.
- Ordering:** Specify figure number.

*NOTE: Supplied with PHD Fig. 3106 3/8-16 spring strut nut and PHD Fig. 4405 end cap.*

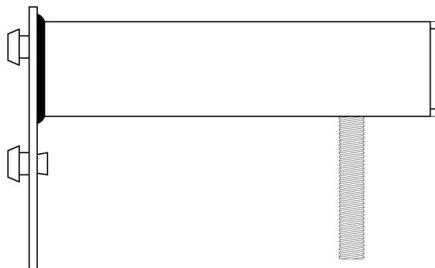
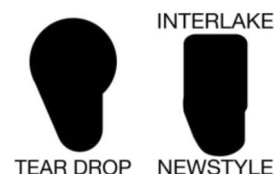

Fig. No.	Flue Space Length		Std. Package	Max. Rec. Load		Wt. Each	
	7	(178)		lbs.	kN	lbs.	kg
995	7	(178)	10	125	(0.56)	1.65	(0.75)



# SEISMIC BRACING



## SWAY BRACE PIPE ATTACHMENT

**FIG. 010**

**Function:** Designed for bracing pipe against sway and seismic disturbance. The pipe attachment component of a sway brace system used in conjunction with a PHD Manufacturing structural attachment fitting, and joined together with a bracing pipe element forms a complete sway brace assembly. Sway brace assemblies are intended to be installed in accordance with NFPA 13 and the manufacturer's installation instructions.

**Size:** Pipe size 1" (25) thru 4" (100).

**Material:** Carbon steel

**Finish:** Electro-galvanized

**Install:** Place over the pipe to be braced, adjust brace angle, and insert bracing pipe through opening leaving a minimum of 1" (25.4) extending from attachment. Brace pipe can be installed on top or bottom of pipe to be braced but must be a minimum of 6" (152.4) away from a pipe joint. Tighten nuts down evenly until hex heads break off.

**Approvals:** Underwriters Laboratories listed for US and Canada and Factory Mutual approved. Listed for use with NFPA and PHD sway brace components only.

**Ordering:** Specify figure number, brace pipe size, and sprinkler pipe size.

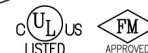
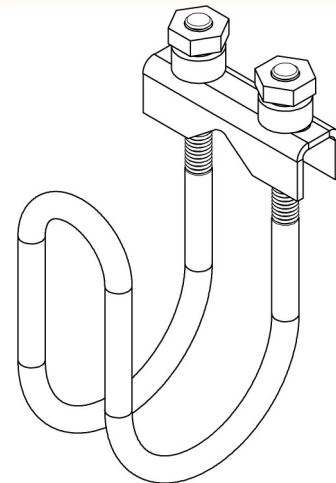

UL Maximum Design Load							
Pipe Size SCH 40		lbs.	kN	Wt. Each			
				1" (25mm) Brace Pipe		1 1/4" (32mm) Brace Pipe	
				lbs.	kg	lbs.	kg
1	(25)	680	(3.02)	0.71	(0.32)	0.75	(0.34)
1 1/4	(32)	680	(3.02)	0.76	(0.34)	0.79	(0.36)
1 1/2	(40)	680	(3.02)	0.79	(0.36)	0.82	(0.37)
2	(50)	680	(3.02)	0.84	(0.38)	0.88	(0.40)
2 1/2	(65)	680	(3.02)	0.90	(0.41)	0.94	(0.43)
3	(80)	680	(3.02)	0.98	(0.44)	1.02	(0.46)
4	(100)	680	(3.02)	1.10	(0.50)	1.14	(0.52)

UL's current Listings, shown above, are predicated on installation in accordance with the latest edition of NFPA 13. The 2016 and earlier editions of NFPA 13 referenced a minimum safety of 1.5 for the load rating as compared to 2.2 for the current edition.

The load ratings noted in table below, Previously Listed Loads, are consistent with the historical cULus Listings that were evaluated to the requirements of UL 203A, Outline of Investigation for Sway Brace Devices for Fire Sprinkler System Piping, based upon a minimum safety factor of 1.5 in accordance with the earlier editions of NFPA 13. The load ratings based upon the 2016 or earlier editions of NFPA 13 should only be used where approved by the Authority Having Jurisdiction (AHJ).

Previously Listed UL Loads							
Pipe Size SCH 40		lbs.	kN	Wt. Each			
				1" (25mm) Brace Pipe		1 1/4" (32mm) Brace Pipe	
				lbs.	kg	lbs.	kg
**1	(25)	*1000	*(4.45)	0.71	(0.32)	0.75	(0.34)
1 1/4	(32)	*1000	*(4.45)	0.76	(0.34)	0.79	(0.36)
1 1/2	(40)	*1000	*(4.45)	0.79	(0.36)	0.82	(0.37)
2	(50)	*1000	*(4.45)	0.84	(0.38)	0.88	(0.40)
2 1/2	(65)	*1000	*(4.45)	0.90	(0.41)	0.94	(0.43)
3	(80)	*1000	*(4.45)	0.98	(0.44)	1.02	(0.46)
4	(100)	*1000	*(4.45)	1.10	(0.50)	1.14	(0.52)

\*Load ratings are based on a minimum safety factor of 1.5 in accordance with NFPA 13-2016 Section A.9.3.5.2.3.

\*\* Restraint only

FM Maximum Design Load				
Brace Pipes 1" or 1 1/4"				
(GB/T3091, EN10255H, or JISG3454)				
Pipe Size SCH 10, 40 & Flow Pipe		Brace Angle From Vertical (Degrees)	lbs.	kN
1	(25)	30° - 44°	340	(1.51)
		45° - 59°	480	(2.13)
		60° - 74°	590	(2.62)
		75° - 90°	660	(2.93)
1 1/4	(32)	30° - 44°	350	(1.55)
		45° - 59°	500	(2.22)
		60° - 74°	610	(2.71)
1 1/2	(40)	75° - 90°	680	(3.02)
		30° - 44°	290	(1.28)
		45° - 59°	420	(1.86)
2	(50)	60° - 74°	510	(2.26)
		75° - 90°	570	(2.53)
		30° - 44°	390	(1.73)
2 1/2	(65)	45° - 59°	550	(2.44)
		60° - 74°	670	(2.98)
		75° - 90°	750	(3.33)
		30° - 44°	440	(1.95)
3	(80)	45° - 59°	620	(2.75)
		60° - 74°	760	(3.38)
		75° - 90°	850	(3.78)
		30° - 44°	470	(2.09)
4	(100)	45° - 59°	660	(2.93)
		60° - 74°	810	(3.33)
		75° - 90°	910	(4.04)
		30° - 44°	430	(1.91)
4	(100)	45° - 59°	610	(2.71)
		60° - 74°	750	(3.33)
4	(100)	75° - 90°	840	(3.73)
		75° - 90°	840	(3.73)

When governed by NFPA13 2019 or later, multiply FM approved loads by 0.682.

THREADED ACCESSORIES  
CPVC STRAPS  
BAND HANGERS  
BEAM CLAMPS  
CLEVIS HANGERS  
PIPE ROLLER SUPPORTS  
SPLIT RING HANGERS  
PIPE CLAMPS  
CENTER LOAD BEAM CLAMPS  
PIPE SHIELDS, INSULATION, & SADDLES  
PIPE GUIDES & SLIDES  
WALL BRACKETS  
PIPE SUPPORTS  
STRUCTURAL ATTACHMENTS  
SEISMIC BRACING

# SEISMIC BRACING

**FIG. 015**

## LARGE SWAY BRACE PIPE ATTACHMENT

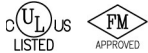
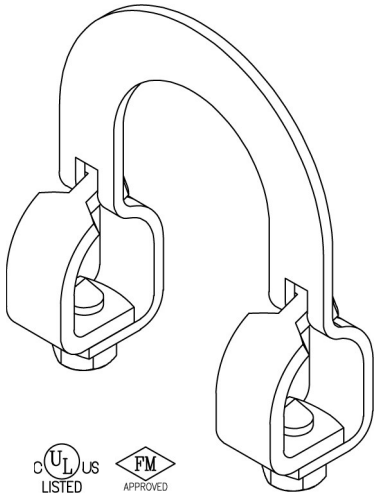

**Function:** Designed for bracing pipe against sway and seismic disturbance. The pipe attachment component of a sway brace system used in conjunction with a PHD Manufacturing structural attachment fitting, and joined together with a bracing pipe element forms a complete sway brace assembly. Sway brace assemblies are intended to be installed in accordance with NFPA 13 and the manufacturer's installation instructions.

**Size:** Pipe size 2<sup>1</sup>/<sub>2</sub>" thru 8".

**Material:** Carbon steel

**Finish:** Electro-galvanized

**Install:** Place over the pipe to be braced, adjust brace angle, and insert bracing pipe through opening leaving a minimum of 1" extending from attachment. Brace pipe can be installed on top or bottom of pipe to be braced but must be a minimum of 6" away from a pipe joint. Tighten two hex head cone point set bolts until heads bottom out on attachment, ensuring proper torque has been applied.

**Approvals:** Underwriters Laboratories listed for US and Canada (2<sup>1</sup>/<sub>2</sub>" thru 6" only) and Factory Mutual approved. Listed for use with NFPA and PHD sway brace components only.

**Ordering:** Specify figure number, brace pipe size, and sprinkler pipe size.

*NOTE: (This product is not compatible with metric pipe.) For metric piping see Fig. 010, Fig. 031, or Fig. 040.*

FM Maximum Design Load							
Brace: 1" Thru 1 1/4" SCH40 Pipe							
Pipe Size SCH 10, 40 & Flow Pipe	Brace Angle From Vertical (Degrees)	lbs.	kN	Wt. Each			
				1" Brace Pipe		1 1/4" Brace Pipe	
				lbs.	kg	lbs.	kg
2 1/2	30°-44°	1020	(4.53)	1.31	(0.59)	1.49	(0.68)
	45°-59°	1440	(6.40)	1.31	(0.59)	1.49	(0.68)
	60°-74°	1770	(7.87)	1.31	(0.59)	1.49	(0.68)
	75°-90°	1970	(8.76)	1.31	(0.59)	1.49	(0.68)
3	30°-44°	1080	(4.80)	1.40	(0.64)	1.57	(0.71)
	45°-59°	1530	(6.80)	1.40	(0.64)	1.57	(0.71)
	60°-74°	1870	(8.31)	1.40	(0.64)	1.57	(0.71)
	75°-90°	2090	(9.29)	1.40	(0.64)	1.57	(0.71)
4	30°-44°	1020	(4.53)	1.53	(0.69)	1.70	(0.77)
	45°-59°	1450	(6.44)	1.53	(0.69)	1.70	(0.77)
	60°-74°	1770	(7.87)	1.53	(0.69)	1.70	(0.77)
	75°-90°	1980	(8.80)	1.53	(0.69)	1.70	(0.77)
6	30°-44°	640	(2.84)	1.81	(0.82)	1.98	(0.90)
	45°-59°	900	(4.00)	1.81	(0.82)	1.98	(0.90)
	60°-74°	1110	(4.93)	1.81	(0.82)	1.98	(0.90)
	75°-90°	1240	(5.51)	1.81	(0.82)	1.98	(0.90)
8	30°-44°	570	(2.53)	2.07	(0.94)	2.24	(1.02)
	45°-59°	810	(3.60)	2.07	(0.94)	2.24	(1.02)
	60°-74°	990	(4.40)	2.07	(0.94)	2.24	(1.02)
	75°-90°	1100	(4.89)	2.07	(0.94)	2.24	(1.02)

When governed by NFPA13 2019 or later, multiply FM approved loads by 0.682.

UL Maximum Design Load		
Pipe Size SCH 10 & 40	lbs.	kN
2 1/2	680	(3.02)
3	680	(3.02)
4	680	(3.02)
6	1090	(4.85)

UL's current Listings, shown above, are predicated on installation in accordance with the latest edition of NFPA 13. The 2016 and earlier editions of NFPA 13 referenced a minimum safety of 1.5 for the load rating as compared to 2.2 for the current edition.

The load ratings noted in table below, Previously Listed Loads, are consistent with the historical cULus Listings that were evaluated to the requirements of UL 203A, Outline of Investigation for Sway Brace Devices for Fire Sprinkler System Piping, based upon a minimum safety factor of 1.5 in accordance with the earlier editions of NFPA 13. The load ratings based upon the 2016 or earlier editions of NFPA 13 should only be used where approved by the Authority Having Jurisdiction (AHJ).

Previously Listed UL Loads		
Pipe Size SCH 10 & 40	lbs.	kN
2 1/2	*1000	*(4.45)
3	*1000	*(4.45)
4	*1000	*(4.45)
6	*1600	*(7.12)

\*Load ratings are based on a minimum safety factor of 1.5 in accordance with NFPA 13-2016 Section A.9.3.5.2.3.

# SEISMIC BRACING



## MULTI-FASTENER ADAPTER

**FIG. 025**

**Function:** Designed for bracing pipe against sway and seismic disturbances. Sway brace adapter used to develop a greater structural connection by providing multiple fastener attachment points. Adapter allows for 2 or 3 NFPA 13 approved fasteners to be used when one fastener is too weak to anchor a sway brace assembly to a structure. Sway brace assemblies are intended to be installed in accordance with NFPA 13 and the manufacturer's installation instructions.

**Size:**  $\frac{1}{2}$ " or  $\frac{3}{4}$ " mounting holes. Braces up to 8" Pipe MAX

**Material:** Carbon steel,  $2\frac{1}{2}$ " X  $2\frac{1}{2}$ " X  $\frac{5}{16}$ " angle

**Finish:** Electro-galvanized

**Install:** Attach to the structural surface as noted in

NFPA13 fastener tables. Please note that the two outermost bolt holes must be used and the middle bolt hole should be used only in conjunction with both outermost bolt holes to ensure concentric loading. Attach a PHD Manufacturing structural attachment fitting to PHD Fig. 025 and follow the instructions provided with said fitting. The PHD structural attachment fitting can pivot around the mounting connection for adjustment to the desired brace angle. Please note that the maximum load will be limited by the PHD Manufacturing structural attachment utilized with this adapter.

**Approvals:** Underwriters Laboratories listed for US and Canada. Listed for use with NFPA fastener tables and PHD sway brace components only.

**Ordering:** Specify figure number and fastener size.

*NOTE: All connecting fasteners are sold separately.*

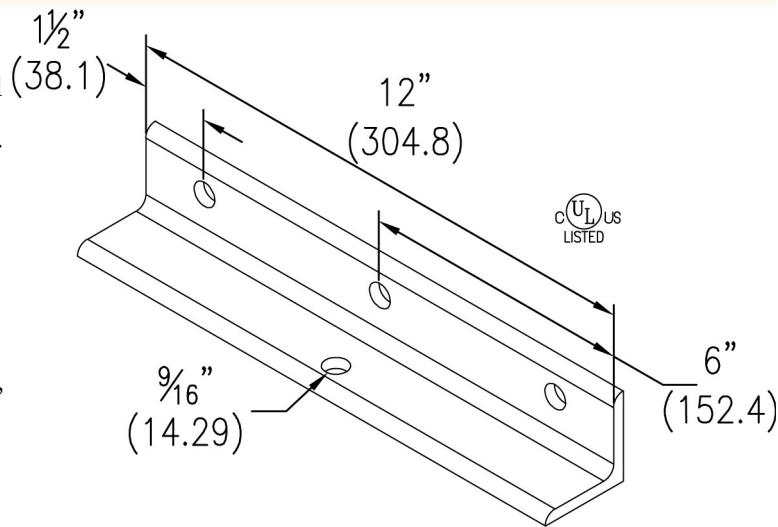

UL Maximum Design Load (8" Pipe Max)				
Fastener Size	lbs.	kN	Wt. Each	
			lbs.	kg
$\frac{1}{2}$	1370	(6.09)	4.55	(2.06)
$\frac{3}{4}$	1370	(6.09)	4.55	(2.06)
UL's current Listings, shown above, are predicated on installation in accordance with the latest edition of NFPA 13. The 2016 and earlier editions of NFPA 13 referenced a minimum safety of 1.5 for the load rating as compared to 2.2 for the current edition. The load ratings noted in table below, Previously Listed Loads, are consistent with the historical cULus Listings that were evaluated to the requirements of UL 203A, Outline of Investigation for Sway Brace Devices for Fire Sprinkler System Piping, based upon a minimum safety factor of 1.5 in accordance with the earlier editions of NFPA 13. The load ratings based upon the 2016 or earlier editions of NFPA 13 should only be used where approved by the Authority Having Jurisdiction (AHJ).				
Previously Listed UL Loads (8" Pipe Max)				
Fastener Size	lbs.	kN	Wt. Each	
			lbs.	kg
$\frac{1}{2}$	*2015	*(8.96)	4.55	(2.06)
$\frac{3}{4}$	*2015	*(8.96)	4.55	(2.06)
*Load ratings are based on a minimum safety factor of 1.5 in accordance with NFPA 13-2016 Section A.9.3.5.2.3.				

THREADED ACCESSORIES  
CPVC STRAPS  
BAND HANGERS  
BEAM CLAMPS  
CLEVIS HANGERS  
PIPE ROLLER SUPPORTS  
SPLIT RING HANGERS  
PIPE CLAMPS  
CENTER LOAD BEAM CLAMPS  
PIPE SHIELDS, INSULATION, & SADDLES  
PIPE GUIDES & SLIDES  
WALL BRACKETS  
PIPE SUPPORTS  
STRUCTURAL ATTACHMENTS  
SEISMIC BRACING

## FIG. 030

## C-CLAMP STRUCTURAL ATTACHMENT

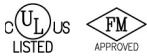
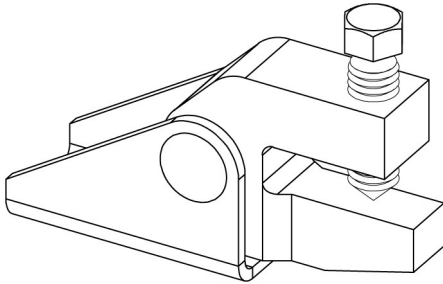

**Function:** Designed for bracing pipe against sway and seismic disturbances. Universal swivel design allows for attachment at any surface angle combined with concentric loading. Structure attachment fitting designed to use 1" thru 2" SCH 40 pipe, structural steel, and PHD 12 gauge strut channel (1001 & 1201) as sway bracing elements. No bracing member thicker than  $\frac{3}{8}$ " can be used in conjunction with this product. Utilize the Fig. 030 with a PHD Manufacturing pipe attachment fitting and a bracing element to form a complete sway brace assembly. Sway brace assemblies are intended to be installed in accordance with NFPA 13 and the manufacturer's installation instructions.

**Size:**  $\frac{1}{2}$ " mounting hole. Braces up to 8" Pipe MAX

**Material:** Ductile iron and carbon steel

**Finish:** Electro-galvanized

**Install:** Mount device to structure then insert brace element into fitting against back of jaw. Tighten set screw finger tight, then tighten until hex head breaks off. Adjust attachment to proper brace angle.

**Approvals:** Underwriters Laboratories listed for US and Canada and Factory Mutual approved. Listed for use with NFPA fastener tables and PHD sway brace components only.

**Ordering:** Specify figure number.

UL Maximum Design Loads (Up to 8" Pipe) - Lateral & Longitudinal Assemblies						
Brace Member	Member Thickness	Member Length	lbs.	kN	Wt. Each	
					lbs.	kg
1" Thru 2" Pipe	SCH 40	Refer to NFPA13	1370	(6.09)	1.23	(0.56)
Structural Steel	$\frac{3}{8}$ " thick MAX	Refer to NFPA13	1370	(6.09)	1.23	(0.56)
1001 Series Strut	12 Ga.	See Chart Below	1370	(6.09)	1.23	(0.56)
1201 Series Strut	12 Ga.	See Chart Below	1370	(6.09)	1.23	(0.56)

UL's current Listings, shown above, are predicated on installation in accordance with the latest edition of NFPA 13. The 2016 and earlier editions of NFPA 13 referenced a minimum safety of 1.5 for the load rating as compared to 2.2 for the current edition.

The load ratings noted in table below, Previously Listed Loads, are consistent with the historical cULus Listings that were evaluated to the requirements of UL 203A, Outline of Investigation for Sway Brace Devices for Fire Sprinkler System Piping, based upon a minimum safety factor of 1.5 in accordance with the earlier editions of NFPA 13. The load ratings based upon the 2016 or earlier editions of NFPA 13 should only be used where approved by the Authority Having Jurisdiction (AHJ).

Previously Listed UL Loads (Up to 8" Pipe) - Lateral & Longitudinal Assemblies						
Brace Member	Member Thickness	Member Length	lbs.	kN	Wt. Each	
					lbs.	kg
1" Thru 2" Pipe	SCH 40	Refer to NFPA13	*2015	*(8.96)	1.23	(0.56)
Structural Steel	$\frac{3}{8}$ " thick MAX	Refer to NFPA13	*2015	*(8.96)	1.23	(0.56)
1001 Series Strut	12 Ga.	See Chart Below	*2015	*(8.96)	1.23	(0.56)
1201 Series Strut	12 Ga.	See Chart Below	*2015	*(8.96)	1.23	(0.56)

\*Load ratings are based on a minimum safety factor of 1.5 in accordance with NFPA 13-2016 Section A.9.3.5.2.3.

FM Maximum Design Load				
For Bracing SCH 10, 40 & Flow Pipe				
Brace Member		Brace Angle From Vertical (Degrees)	lbs.	kN
1" Thru 2" SCH 40 Pipe	(GB/T3091, EN10255H, or JISG3454)	30°-44°	1270	(5.64)
		45°-59°	2040	(9.07)
		60°-74°	2450	(10.89)
		75°-90°	2740	(12.18)
$\frac{1}{4}$ " Thru $\frac{3}{8}$ " Thick Structural Steel		30°-44°	900	(4.00)
		45°-59°	1280	(5.69)
		60°-74°	1570	(6.98)
PHD 12 Gauge Strut Channel 1001 & 1201		30°-44°	1070	(4.75)
		45°-59°	1440	(6.40)
		60°-74°	1740	(7.73)
		75°-90°	1940	(8.62)

When governed by NFPA13 2019 or later, multiply FM approved loads by 0.682.

Strut Fig. #	PHD Strut Channel Maximum Horizontal Load 90° From Vertical													
	r		l/r =	100			200			300				
	Max	lbs.		kN	Max	lbs.	kN	Max	lbs.	kN				
1001	0.580	(14.73)	58"	(1473.2)	4670	(20.77)	116"	(2946.4)	1165	(5.18)	174"	(4419.6)	518	(2.30)
1201	0.297	(7.54)	29"	(736.6)	3260	(14.50)	59"	(1498.6)	785	(3.49)	89"	(2260.6)	345	(1.53)

FIG. 031 Horizontal Prying Factors Per NFPA 13										
Brace Orientation*	A	B	C	D	E	F	G	H	I	
Brace Angle**	30° - 44°	45° - 59°	60° - 90°	30° - 44°	45° - 59°	60° - 90°	30° - 44°	45° - 59°	60° - 90°	
Prying Factor (Pr)	2.396 (60.85)	1.098 (27.90)	1.285 (32.64)	1.677 (42.60)	1.353 (34.36)	2.125 (53.98)	2.570 (65.28)	1.817 (46.16)	1.484 (37.69)	

\* Brace Orientation per NFPA 13.

\*\* Brace Pipe Angles are determined from vertical.

Unless otherwise specified, all dimensions on drawings and in charts are in inches and dimensions shown in parentheses are in millimeters.

# SEISMIC BRACING



## CLAMPING PIPE ATTACHMENT

**FIG. 031**

**Function:** Designed for bracing pipe against sway and seismic disturbance. Versatile design allows for attachment at any angle and the ability to be used in a lateral or longitudinal bracing configuration. The pipe attachment component of a sway brace system used in conjunction with a PHD Manufacturing structural attachment fitting and joined together with a bracing element form a complete sway brace assembly. Sway brace assemblies are intended to be installed in accordance with NFPA 13 and the manufacturer's installation instructions.

**Size:** Pipe sizes 2" thru 8". Can use 1" thru 2" SCH 40 pipe, structural steel, and PHD 12 gauge strut channel (1001 & 1201) as sway bracing elements.

**Material:** Ductile iron and carbon steel.

**Finish:** Electro-galvanized

**Install:** Place attachment around pipe to be braced, positioning brace attachment as needed, then tighten clamping bolts and nuts finger tight. Insert brace component into fitting against back of jaw. Tighten set screw finger tight, adjust brace angle as needed, then tighten set screw until hex head breaks off. Then evenly torque clamping bolts until hex portion of clamping nuts break off.

**Approvals:** Underwriters Laboratories listed for US and Canada and Factory Mutual approved. Listed for use with PHD sway brace components only.

**Ordering:** Specify figure number and sprinkler pipe size.

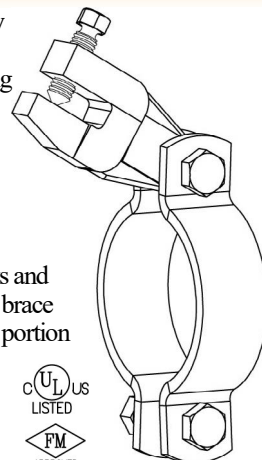

UL Maximum Design Loads					
All Pipe Sizes, SCH 10 & 40 (3 1/2 SCH 40 only) Lateral & Longitudinal Assemblies					
Brace Member	Member Thickness	Member Length	lbs.	kN	
1" Thru 2" Pipe	SCH 40	Refer to NFPA13	1370	(6.09)	
Structural Steel	1/4" & 3/8" thick	Refer to NFPA13	1370	(6.09)	
1001 Series Strut	12 Ga.	See Chart Below	1370	(6.09)	
1201 Series Strut	12 Ga.	See Chart Below	1370	(6.09)	
UL's current Listings, shown above, are predicated on installation in accordance with the latest edition of NFPA 13. The 2016 and earlier editions of NFPA 13 referenced a minimum safety of 1.5 for the load rating as compared to 2.2 for the current edition.					
The load ratings noted in table below, Previously Listed Loads, are consistent with the historical cULus Listings that were evaluated to the requirements of UL 203A, Outline of Investigation for Sway Brace Devices for Fire Sprinkler System Piping, based upon a minimum safety factor of 1.5 in accordance with the earlier editions of NFPA 13. The load ratings based upon the 2016 or earlier editions of NFPA 13 should only be used where approved by the Authority Having Jurisdiction (AHJ).					
Previously Listed UL Loads					
All Pipe Sizes, SCH 10 & 40 (3 1/2 SCH 40 only) Lateral & Longitudinal Assemblies					
Brace Member	Member Thickness	Member Length	lbs.	kN	
1" Thru 2" Pipe	SCH 40	Refer to NFPA13	*2015	*(8.96)	
Structural Steel	1/4" & 3/8" thick	Refer to NFPA13	*2015	*(8.96)	
1001 Series Strut	12 Ga.	See Chart Below	*2015	*(8.96)	
1201 Series Strut	12 Ga.	See Chart Below	*2015	*(8.96)	
*Load ratings are based on a minimum safety factor of 1.5 in accordance with NFPA 13-2016 Section A.9.3.5.2.3.					
FM Maximum Design Load (All Sizes)					
For Bracing SCH 10, 40 & Flow Pipe					
Brace Member		Direction	Brace Angle (Degrees)	lbs.	kN
1" Thru 2" SCH 40 Pipe	(GB/T3091, EN10255H, or JISG3454)	Lateral	30°-44°	1270	(5.64)
			45°-59°	1800	(9.07)
			60°-74°	2200	(10.89)
			75°-90°	2460	(12.18)
1/4" Thru 3/8" Thick Structural Steel		Lateral & Longitudinal	30°-44°	900	(4.00)
			45°-59°	1280	(5.69)
			60°-74°	1570	(6.98)
			75°-90°	1750	(7.78)
PHD 12 Gauge Strut Channel 1001 & 1201		Lateral & Longitudinal	30°-44°	1070	(4.75)
			45°-59°	1440	(6.40)
			60°-74°	1740	(7.73)
			75°-90°	1940	(8.62)

When governed by NFPA13 2019 or later, multiply FM approved loads by 0.682.

FM Maximum Design Load					
Brace: 1" Thru 2" SCH40 Pipe (GB/T3091, EN10255H, or JISG3454)					
Pipe Size SCH 10, 40 & Flow Pipe	Brace Angle From Vertical (Degrees)	Longitudinal		Wt. Each	
		lbs.	kN	lbs.	kg
2 (50)	30°-44°	1370	(6.09)	2.60	(1.18)
	45°-59°	1930	(8.58)		
	60°-74°	2370	(10.54)		
	75°-90°	2810	(12.49)		
2 1/2 (65)	30°-44°	1500	(6.67)	2.77	(1.26)
	45°-59°	2120	(9.43)		
	60°-74°	2600	(11.56)		
	75°-90°	2900	(12.89)		
3 (80)	30°-44°	1370	(6.09)	3.00	(1.36)
	45°-59°	1930	(8.58)		
	60°-74°	2370	(10.54)		
	75°-90°	2810	(12.49)		
3 1/2 (90)	30°-44°	1370	(6.09)	3.13	(1.42)
	45°-59°	1930	(8.58)		
	60°-74°	2370	(10.54)		
	75°-90°	2810	(12.49)		
4 (100)	30°-44°	1370	(6.09)	3.30	(1.50)
	45°-59°	1930	(8.58)		
	60°-74°	2370	(10.54)		
	75°-90°	2810	(12.49)		
5 (125)	30°-44°	1370	(6.09)	4.57	(2.07)
	45°-59°	1930	(8.58)		
	60°-74°	2370	(10.54)		
	75°-90°	2810	(12.49)		
6 (150)	30°-44°	1410	(6.27)	5.42	(2.46)
	45°-59°	2000	(8.89)		
	60°-74°	2450	(10.89)		
	75°-90°	2730	(12.14)		
8 (200)	30°-44°	1320	(5.87)	8.52	(3.86)
	45°-59°	1870	(8.31)		
	60°-74°	2290	(10.18)		
	75°-90°	2550	(11.34)		

When governed by NFPA13 2019 or later, multiply FM approved loads by 0.682.

Strut Fig. #	PHD Strut Channel Maximum Horizontal Load 90° From Vertical													
	r	l/r =	100			200			300					
			Max	lbs.	kN	Max	lbs.	kN	Max	lbs.	kN			
1001	0.580	(14.73)	58"	(1473.2)	4670	(20.77)	116"	(2946.4)	1165	(5.18)	174"	(4419.6)	518	(2.30)
1201	0.297	(7.54)	29"	(736.6)	3260	(14.50)	59"	(1498.6)	785	(3.49)	89"	(2260.6)	345	(1.53)

Unless otherwise specified, all dimensions on drawings and in charts are in inches and dimensions shown in parentheses are in millimeters.

THREADED ACCESSORIES

CPVC STRAPS

BAND HANGERS

BEAM CLAMPS

CLEVIS HANGERS

PIPE ROLLER SUPPORTS

PIPE RING HANGERS

SPLIT RING HANGERS

PIPE CLAMPS

CENTER LOAD BEAM CLAMPS

PIPE SHIELDS, INSULATION, & SADDLES

PIPE GUIDES & SLIDES

WALL BRACKETS

PIPE SUPPORTS

STRUCTURAL ATTACHMENTS

SEISMIC BRACING

**FIG. 035**

## SWAY BRACE BAR JOIST ADAPTER

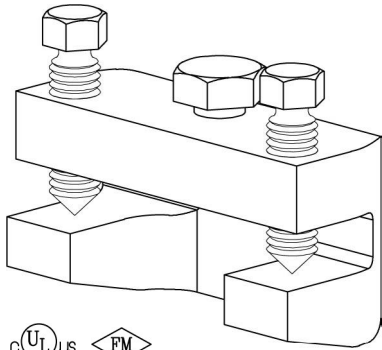

**Function:** Sway brace adapter used to attach a PHD Manufacturing sway brace assembly to a steel bar joist or structural member of  $\frac{3}{8}$ " maximum thickness. To provide a point of connection when drilling or welding is not allowed or not practical. Sway brace assemblies are intended to be installed in accordance with NFPA 13 and the manufacturer's installation instructions.

**Size:** Braces up to 8" Pipe MAX. Attaches to  $\frac{3}{8}$ " thick MAX structural members. When attaching to a structure thicker than  $\frac{3}{8}$ ", please see PHD Manufacturing Fig. 045.

**Material:** Ductile iron

**Finish:** Electro-galvanized

**Install:** Place on structural member with the flange contacting the back of the jaw. Tighten set screws finger tight, then evenly tighten until hex heads break off. Attach PHD structural attachment to Fig. 035 with the supplied attachment bolt, ensuring that the attachment bolt head bottoms out securely. Please note that the maximum load will be limited by the PHD Manufacturing structural attachment utilized with this adapter.

**Approvals:** Underwriters Laboratories listed for US and Canada and Factory Mutual approved. Listed for use with NFPA fastener tables and PHD sway brace components only.

**Ordering:** Specify figure number.

UL Maximum Design Load					
Pipe Size	(200)	lbs.	kN	Wt. Each	
				lbs.	kg
8" MAX	(200)	1370	(6.09)	2.38	(1.08)

UL's current Listings, shown above, are predicated on installation in accordance with the latest edition of NFPA 13. The 2016 and earlier editions of NFPA 13 referenced a minimum safety of 1.5 for the load rating as compared to 2.2 for the current edition.

The load ratings noted in table below, Previously Listed Loads, are consistent with the historical cULus Listings that were evaluated to the requirements of UL 203A, Outline of Investigation for Sway Brace Devices for Fire Sprinkler System Piping, based upon a minimum safety factor of 1.5 in accordance with the earlier editions of NFPA 13. The load ratings based upon the 2016 or earlier editions of NFPA 13 should only be used where approved by the Authority Having Jurisdiction (AHJ).

Previously Listed UL Loads					
Pipe Size	(200)	lbs.	kN	Wt. Each	
				lbs.	kg
8" MAX	(200)	*2015	*(8.96)	2.38	(1.08)

\*Load ratings are based on a minimum safety factor of 1.5 in accordance with NFPA 13-2016 Section A.9.3.5.2.3.

FM Maximum Design Load							
Beam Flange Thickness	Brace Angle From Vertical (Degrees)	X-Z		Y-Z		A-B	
		lbs.	kN	lbs.	kN	lbs.	kN
$\frac{3}{8}$ " Max	30°-44°	1040	(4.62)	970	(4.31)	1150	(5.11)
	45°-59°	1490	(6.62)	1370	(6.09)	1660	(7.38)
	60°-74°	1800	(8.00)	2060	(9.16)	1990	(8.85)
	75°-90°	2010	(8.94)	2300	(10.23)	2220	(9.87)

When governed by NFPA13 2019 or later, multiply FM approved loads by 0.682.

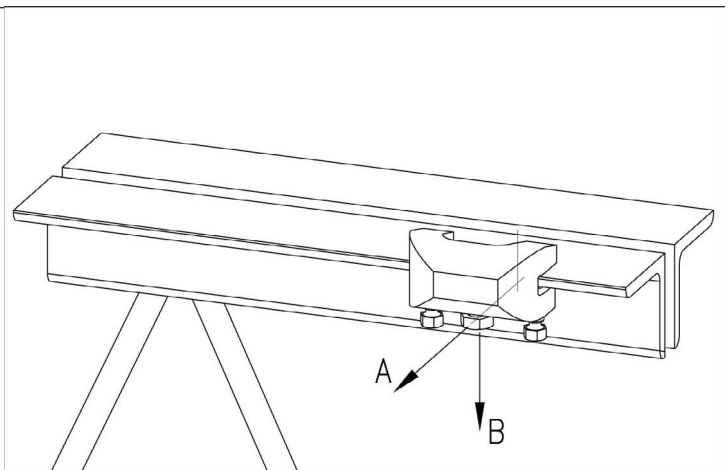
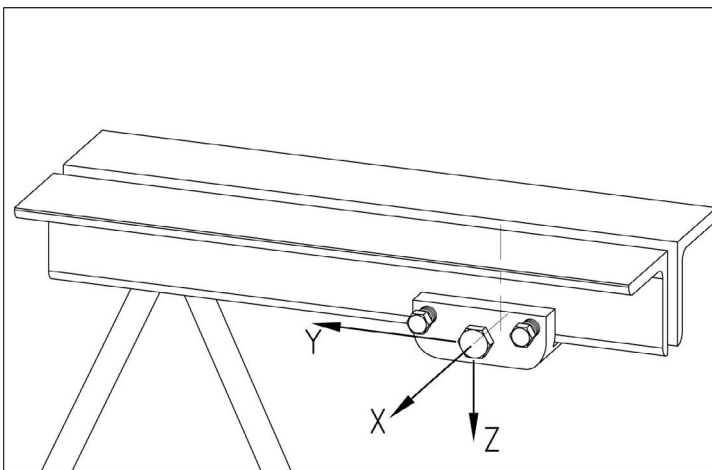

Unless otherwise specified, all dimensions on drawings and in charts are in inches and dimensions shown in parentheses are in millimeters.



# SEISMIC BRACING



## SUPPORTING PIPE ATTACHMENT

## FIG. 040

**Function:** Designed for bracing pipe against sway and seismic disturbance. Versatile design allows for attachment at any angle and the ability to be used in a lateral or longitudinal bracing configuration. The pipe attachment component of a sway brace system used in conjunction with two PHD Manufacturing structural attachment fittings and joined together with a bracing element form a complete sway brace assembly. Sway brace assemblies are intended to be installed in accordance with NFPA 13 and the manufacturer's installation instructions.

**Size:** Pipe sizes 2" thru 8". Refer to PHD Structural attachment fitting literature regarding appropriate brace members, sizes, and further loading limitations.

**Material:** Carbon steel

**Finish:** Electro-galvanized

**Install:** Attach PHD Manufacturing structural attachment fitting, Fig. 030 (sold separately), to Fig. 040 using supplied fastener. Place the assembly around the pipe to be braced, positioning welded clevis on top of the pipe, then tighten clamping bolts and nuts finger tight. Follow PHD Manufacturing structural attachment fitting's instructions for attaching to brace element. Adjust the brace element to the desired angle then tighten the supplied fastener to lock the PHD Manufacturing structural attachment fitting, Fig. 030, securely in position with the Fig. 040. Then evenly torque clamping bolts until hex portion of clamping nuts break off.

**Approvals:** Underwriters Laboratories listed for US and Canada as a hanger. Factory Mutual approved as a sway brace only. Listed for use with PHD sway brace components only.

**Ordering:** Specify figure number and sprinkler pipe size.

*NOTE: Figure 030 sold separately.*

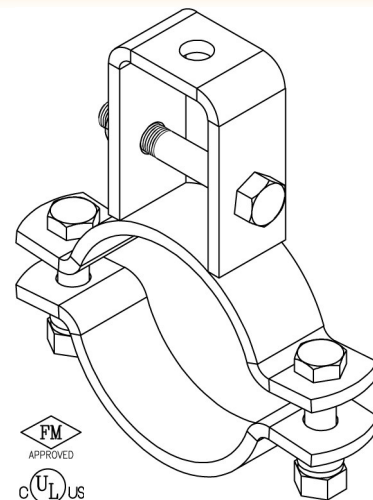

Pipe Size SCH 10, 40 & Flow Pipe		Brace Angle From Vertical (Degrees)	FM Maximum Design Load			
			Lateral		Longitudinal	
			lbs.	kN	lbs.	kN
2	(50)	30°-44°	1070	(4.75)	1260	(5.60)
		45°-59°	1520	(6.76)	1440	(6.40)
		60°-74°	1860	(8.27)	1740	(7.73)
		75°-90°	2080	(9.25)	1940	(8.62)
2½	(65)	30°-44°	960	(4.27)	1000	(4.44)
		45°-59°	1360	(6.04)	1420	(6.31)
		60°-74°	1670	(7.42)	1740	(7.73)
		75°-90°	1860	(8.27)	1940	(8.62)
3	(80)	30°-44°	960	(4.27)	1000	(4.44)
		45°-59°	1360	(6.04)	1420	(6.31)
		60°-74°	1670	(7.42)	1740	(7.73)
		75°-90°	1860	(8.27)	1940	(8.62)
3½	(90)	30°-44°	960	(4.27)	1000	(4.44)
		45°-59°	1360	(6.04)	1420	(6.31)
		60°-74°	1670	(7.42)	1740	(7.73)
		75°-90°	1860	(8.27)	1940	(8.62)
4	(100)	30°-44°	960	(4.27)	1110	(4.93)
		45°-59°	1360	(6.04)	1490	(6.62)
		60°-74°	1670	(7.42)	1800	(8.00)
		75°-90°	1860	(8.27)	1920	(8.54)
5	(125)	30°-44°	960	(4.27)	1110	(4.93)
		45°-59°	1360	(6.04)	1490	(6.62)
		60°-74°	1670	(7.42)	1800	(8.00)
		75°-90°	1860	(8.27)	1920	(8.54)
6	(150)	30°-44°	1000	(4.44)	1280	(5.69)
		45°-59°	1420	(6.31)	1810	(8.05)
		60°-74°	1740	(7.73)	2210	(9.83)
		75°-90°	1940	(8.62)	2470	(10.98)
8	(200)	30°-44°	1350	(6.00)	1160	(5.15)
		45°-59°	1900	(8.45)	1650	(7.33)
		60°-74°	2330	(10.36)	2020	(8.98)
		75°-90°	2600	(11.56)	2250	(10.00)

UL Maximum Design Load							
Pipe Size SCH 10 & 40		Hanger Rod Size		Rec. Max. Hanger Load		Wt. Each	
				lbs.	kN	lbs.	kg
2	(50)	3/8	(10)	730	(3.25)	2.40	(1.09)
2½	(65)	1/2	(12)	850	(3.78)	2.58	(1.17)
3	(80)	1/2	(12)	1000	(4.45)	2.80	(1.27)
*3½	(90)	1/2	(12)	1000	(4.45)	2.94	(1.33)
4	(100)	5/8	(16)	1000	(4.45)	3.28	(1.49)
5	(125)	5/8	(16)	1600	(7.12)	4.95	(2.25)
6	(150)	3/4	(20)	1600	(7.12)	6.93	(3.14)
8	(200)	3/4	(20)	2015	(8.96)	9.97	(4.52)

\* SCH 40 pipe only

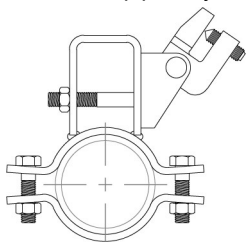

**Lateral Brace**

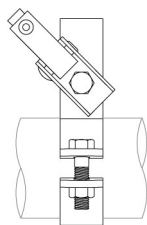

**Longitudinal Brace**

When governed by NFPA13 2019 or later, multiply FM approved loads by 0.682.

Unless otherwise specified, all dimensions on drawings and in charts are in inches and dimensions shown in parentheses are in millimeters.

THREADED  
ACCESSORIES

CPVC  
STRAPS

BAND  
HANGERS

BEAM  
CLAMPS

CLEVIS  
HANGERS

PIPE ROLLER  
SUPPORTS

SPLIT RING  
HANGERS

PIPE  
CLAMPS

CENTER LOAD  
BEAM CLAMPS

PIPE SHIELDS,  
INSULATION, & SADDLES

PIPE GUIDES  
& SLIDES

WALL  
BRACKETS

PIPE  
SUPPORTS

STRUCTURAL  
ATTACHMENTS

SEISMIC  
BRACING



www.phd-mfg.com

# SEISMIC BRACING

**FIG. 045**

## SWAY BRACE STRUCTURAL ADAPTER

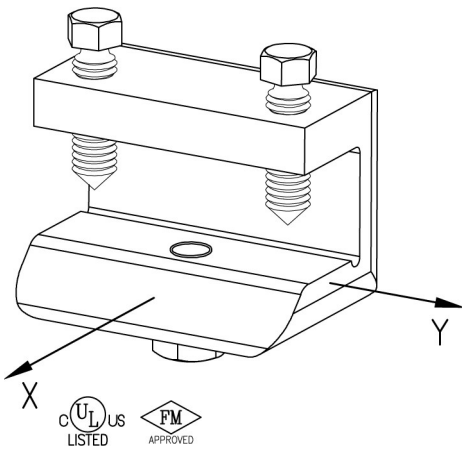

**Function:** Sway brace adapter used to attach a PHD Manufacturing sway brace assembly to a steel structural member of  $\frac{3}{8}$ " minimum and  $1\frac{1}{4}$ " maximum thickness. To provide a point of connection when drilling or welding is not allowed or not practical. Sway brace assemblies are intended to be installed in accordance with NFPA 13 and the manufacturer's installation instructions.

**Size:** Braces up to 8" Pipe MAX. Attaches to  $\frac{3}{8}$ " MINIMUM and  $1\frac{1}{4}$ " MAX thick structural members. When attaching to a structure less than  $\frac{3}{8}$ " thick, please see PHD Manufacturing Fig. 035.

**Material:** Ductile iron

**Finish:** Electro-galvanized

**Install:** Place on structural member with the flange contacting the back of the jaw. Tighten set screws finger tight, then evenly tighten until hex heads break off. Attach PHD structural attachment to Fig. 045 with the supplied attachment bolt, ensuring that the attachment bolt head bottoms out securely. Please note that the maximum load will be limited by the PHD Manufacturing structural attachment utilized with this adapter.

**Approvals:** Underwriters Laboratories listed for US and Canada and Factory Mutual approved. Listed for use with NFPA fastener tables and PHD sway brace components only.

**Ordering:** Specify figure number.

UL Maximum Design Load					
Pipe Size	(200)	lbs.	kN	Wt. Each	
				lbs.	kg
8" MAX	(200)	1370	(6.09)	2.38	(1.08)
<p>UL's current Listings, shown above, are predicated on installation in accordance with the latest edition of NFPA 13. The 2016 and earlier editions of NFPA 13 referenced a minimum safety of 1.5 for the load rating as compared to 2.2 for the current edition.</p> <p>The load ratings noted in table below, Previously Listed Loads, are consistent with the historical cULus Listings that were evaluated to the requirements of UL 203A, Outline of Investigation for Sway Brace Devices for Fire Sprinkler System Piping, based upon a minimum safety factor of 1.5 in accordance with the earlier editions of NFPA 13. The load ratings based upon the 2016 or earlier editions of NFPA 13 should only be used where approved by the Authority Having Jurisdiction (AHJ).</p>					
Previously Listed UL Loads					
Pipe Size	(200)	lbs.	kN	Wt. Each	
				lbs.	kg
8" MAX	(200)	*2015	*(8.96)	2.38	(1.08)
*Load ratings are based on a minimum safety factor of 1.5 in accordance with NFPA 13-2016 Section A.9.3.5.2.3.					

FM Maximum Design Load					
Beam Flange Thickness	Brace Angle From Vertical (Degrees)	X		Y	
		lbs.	kN	lbs.	kN
$\frac{3}{8}$ " MIN - $1\frac{1}{4}$ " MAX	30°-44°	1150	(5.11)	900	(4.00)
	45°-59°	1800	(8.00)	1050	(4.67)
	60°-74°	2230	(9.91)	1260	(5.60)
	75°-90°	2460	(10.94)	1410	(6.27)

When governed by NFPA13 2019 or later, multiply FM approved loads by 0.682.

## STANDARD BEAM INFORMATION

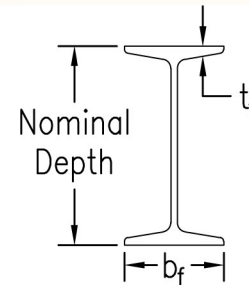
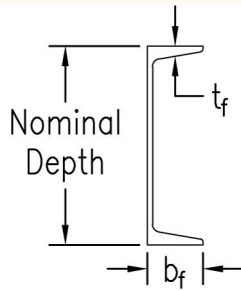

AMERICAN STANDARD 'C' SHAPE CHANNELS

Designation Nom. Depth & Weight		Flange Width $b_f$		Flange Thickness $t_f$	
in. X lbs./ft	mm X kg/m				
C3 X 4.1	(C75 X 6.1)	1 <sup>3</sup> / <sub>8</sub>	(35)	.273	(6.9)
C3 X 5	(C75 X 7.4)	1 <sup>1</sup> / <sub>2</sub>	(37)	.273	(6.9)
C3 X 6	(C75 X 8.9)	1 <sup>5</sup> / <sub>8</sub>	(40)	.273	(6.9)
C4 X 5.4	(C100 X 8)	1 <sup>9</sup> / <sub>16</sub>	(40)	.296	(7.5)
C4 X 7.25	(C100 X 10.8)	1 <sup>3</sup> / <sub>4</sub>	(44)	.296	(7.5)
C5 X 6.7	(C130 X 10)	1 <sup>3</sup> / <sub>4</sub>	(44)	.320	(8.1)
C5 X 9	(C130 X 13.4)	1 <sup>7</sup> / <sub>8</sub>	(47)	.320	(8.1)
C6 X 8.2	(C150 X 12.2)	1 <sup>15</sup> / <sub>16</sub>	(48)	.343	(8.7)
C6 X 10.5	(C150 X 15.6)	2	(51)	.343	(8.7)
C6 X 13	(C150 X 19.3)	2 <sup>1</sup> / <sub>8</sub>	(54)	.343	(8.7)
C7 X 9.8	(C180 X 14.6)	2 <sup>1</sup> / <sub>16</sub>	(53)	.366	(9.3)
C7 X 12.25	(C180 X 18.2)	2 <sup>3</sup> / <sub>16</sub>	(55)	.366	(9.3)
C7 X 14.75	(C180 X 22)	2 <sup>1</sup> / <sub>4</sub>	(57)	.366	(9.3)
C8 X 11.5	(C200 X 17.1)	2 <sup>1</sup> / <sub>4</sub>	(57)	.390	(9.9)
C8 X 13.75	(C200 X 20.5)	2 <sup>3</sup> / <sub>8</sub>	(59)	.390	(9.9)
C8 X 18.75	(C200 X 27.9)	2 <sup>1</sup> / <sub>2</sub>	(63)	.390	(9.9)
C9 X 13.4	(C230 X 19.9)	2 <sup>7</sup> / <sub>16</sub>	(61)	.413	(10.5)
C9 X 15	(C230 X 22)	2 <sup>1</sup> / <sub>2</sub>	(63)	.413	(10.5)
C9 X 20	(C230 X 30)	2 <sup>5</sup> / <sub>8</sub>	(67)	.413	(10.5)
C10 X 15.3	(C250 X 22.8)	2 <sup>5</sup> / <sub>8</sub>	(67)	.436	(11.1)
C10 X 20	(C250 X 30)	2 <sup>3</sup> / <sub>4</sub>	(69)	.436	(11.1)
C10 X 25	(C250 X 37)	2 <sup>7</sup> / <sub>8</sub>	(73)	.436	(11.1)
C10 X 30	(C250 X 45)	3	(76)	.436	(11.1)
C12 X 20.7	(C310 X 30.8)	2 <sup>15</sup> / <sub>16</sub>	(74)	.501	(12.7)
C12 X 25	(C310 X 37)	3	(76)	.501	(12.7)
C12 X 30	(C310 X 45)	3 <sup>1</sup> / <sub>8</sub>	(80)	.501	(12.7)
C15 X 33.9	(C380 X 50.4)	3 <sup>3</sup> / <sub>8</sub>	(86)	.650	(16.5)
C15 X 40	(C380 X 60)	3 <sup>1</sup> / <sub>2</sub>	(89)	.650	(16.5)
C15 X 50	(C380 X 74)	3 <sup>3</sup> / <sub>4</sub>	(94)	.650	(16.5)
C18 X 42.7	(C460 X 63.5)	4	(102)	.625	(15.9)
C18 X 45.8	(C460 X 68.1)	4	(102)	.625	(15.9)
C18 X 51.9	(C460 X 77.2)	4 <sup>1</sup> / <sub>8</sub>	(106)	.625	(15.9)
C18 X 58	(C460 X 86.3)	4 <sup>1</sup> / <sub>4</sub>	(112)	.625	(15.9)

AMERICAN STANDARD 'S' SHAPE I-BEAMS

Designation Nom. Depth & Weight		Flange Width $b_f$		Flange Thickness $t_f$	
in. X lbs./ft	mm X kg/m				
S3 X 5.7	(S75 X 8.5)	2 <sup>3</sup> / <sub>8</sub>	(59)	.260	(6.6)
S3 X 7.5	(S75 X 11.2)	2 <sup>1</sup> / <sub>2</sub>	(63)	.260	(6.6)
S4 X 7.7	(S100 X 11.5)	2 <sup>5</sup> / <sub>8</sub>	(68)	.293	(7.4)
S4 X 9.5	(S100 X 14.1)	2 <sup>3</sup> / <sub>4</sub>	(71)	.293	(7.4)
S5 X 10	(S130 X 15)	3	(76)	.326	(8.3)
S5 X 14.75	(S130 X 22)	3 <sup>1</sup> / <sub>4</sub>	(83)	.326	(8.3)
S6 X 12.5	(S150 X 18.6)	3 <sup>3</sup> / <sub>8</sub>	(85)	.359	(9.1)
S6 X 17.25	(S150 X 25.7)	3 <sup>11</sup> / <sub>16</sub>	(91)	.359	(9.1)
S7 X 15.3	(S180 X 22.8)	3 <sup>5</sup> / <sub>8</sub>	(93)	.392	(10.0)
S7 X 20	(S180 X 29.8)	3 <sup>7</sup> / <sub>8</sub>	(98)	.392	(10.0)
S8 X 18.4	(S200 X 27.4)	4	(102)	.425	(10.8)
S8 X 23	(S200 X 34)	4 <sup>1</sup> / <sub>8</sub>	(106)	.425	(10.8)
S10 X 25.4	(S250 X 37.8)	4 <sup>5</sup> / <sub>8</sub>	(118)	.491	(12.5)
S10 X 35	(S250 X 52)	4 <sup>15</sup> / <sub>16</sub>	(126)	.491	(12.5)
S12 X 31.8	(S310 X 47.3)	5	(127)	.544	(13.8)
S12 X 35	(S310 X 52)	5 <sup>1</sup> / <sub>16</sub>	(129)	.544	(13.8)
S12 X 40.8	(S310 X 60.7)	5 <sup>1</sup> / <sub>4</sub>	(133)	.659	(16.7)
S12 X 50	(S310 X 74)	5 <sup>1</sup> / <sub>2</sub>	(139)	.659	(16.7)
S15 X 42.9	(S380 X 64)	5 <sup>1</sup> / <sub>2</sub>	(140)	.622	(15.8)
S15 X 50	(S380 X 74)	5 <sup>5</sup> / <sub>8</sub>	(143)	.622	(15.8)
S18 X 54.7	(S460 X 81.4)	6	(152)	.691	(17.6)
S18 X 70	(S460 X 104)	6 <sup>1</sup> / <sub>4</sub>	(159)	.691	(17.6)
S20 X 66	(S510 X 98.2)	6 <sup>1</sup> / <sub>4</sub>	(159)	.795	(20.2)
S20 X 75	(S510 X 112)	6 <sup>3</sup> / <sub>8</sub>	(162)	.795	(20.2)
S20 X 86	(S510 X 128)	7 <sup>1</sup> / <sub>16</sub>	(179)	.920	(23.4)
S20 X 96	(S510 X 143)	7 <sup>3</sup> / <sub>16</sub>	(183)	.920	(23.4)
S24 X 80	(S610 X 119)	7	(178)	.870	(22.1)
S24 X 90	(S610 X 134)	7 <sup>1</sup> / <sub>8</sub>	(181)	.870	(22.1)
S24 X 100	(S610 X 149)	7 <sup>1</sup> / <sub>4</sub>	(184)	.870	(22.1)
S24 X 106	(S610 X 158)	7 <sup>7</sup> / <sub>8</sub>	(200)	1.090	(27.7)
S24 X 121	(S610 X 180)	8 <sup>1</sup> / <sub>16</sub>	(204)	1.090	(27.7)

**Note:** All standard beam information is taken from ASTM A6-86

Unless otherwise specified, all dimensions on drawings and in charts are in inches and dimensions shown in parentheses are in millimeters.

# TECHNICAL DATA

## STANDARD BEAM INFORMATION

Designation Nom. Depth & Weight		Flange Width b <sub>f</sub>	Flange Thickness t <sub>f</sub>	Designation Nom. Depth & Weight		Flange Width b <sub>f</sub>	Flange Thickness t <sub>f</sub>
in. X lbs./ft	mm X kg/m			in. X lbs./ft	mm X kg/m		
W4 X 13	(W100 X 19.3)	4 1/16 (103)	.345 (8.8)	W12 X 65	(W310 X 97)	12	.605 (15.4)
W5 X 16	(W130 X 23.8)	5 (127)	.360 (9.1)	W12 X 72	(W310 X 107)	12	.670 (17.0)
W5 X 19	(W130 X 28.1)	5 (127)	.430 (10.9)	W12 X 79	(W310 X 117)	12 1/16 (306)	.735 (18.7)
W6 X 9	(W150 X 13.5)	3 5/16 (100)	.215 (5.5)	W12 X 87	(W310 X 129)	12 1/8 (308)	.810 (20.6)
W6 X 12	(W150 X 18.)	4 (102)	.280 (7.1)	W12 X 96	(W310 X 143)	12 1/8 (308)	.900 (22.9)
W6 X 16	(W150 X 24.)	4 (102)	.405 (10.3)	W12 X 106	(W310 X 158)	12 1/4 (311)	.990 (25.1)
W6 X 20	(W150 X 29.8)	6 (152)	.365 (9.3)	W12 X 120	(W310 X 179)	12 3/16 (313)	1.105 (28.1)
W6 X 25	(W150 X 37.1)	6 1/16 (154)	.455 (11.6)	W12 X 136	(W310 X 202)	12 3/8 (314)	1.250 (31.8)
W8 X 10	(W200 X 15.0)	3 5/16 (100)	.205 (5.2)	W12 X 152	(W310 X 226)	12 1/2 (318)	1.400 (35.6)
W8 X 13	(W200 X 19.3)	4 (102)	.255 (6.5)	W12 X 170	(W310 X 253)	12 5/16 (319)	1.560 (39.6)
W8 X 15	(W200 X 22.5)	4 (102)	.315 (8.0)	W12 X 190	(W310 X 283)	12 11/16 (322)	1.735 (44.1)
W8 X 18	(W200 X 26.6)	5 1/4 (133)	.330 (8.4)	W12 X 210	(W310 X 313)	12 3/4 (324)	1.900 (48.3)
W8 X 21	(W200 X 31.3)	5 1/4 (133)	.400 (10.2)	W12 X 230	(W310 X 342)	12 5/8 (327)	2.070 (52.6)
W8 X 24	(W200 X 35.9)	6 1/2 (165)	.400 (10.2)	W12 X 252	(W310 X 375)	13 (330)	2.250 (57.2)
W8 X 28	(W200 X 41.7)	6 1/2 (165)	.465 (11.8)	W14 X 22	(W360 X 32.9)	5 (127)	.335 (8.5)
W8 X 31	(W200 X 46.1)	8 (203)	.435 (11.0)	W14 X 26	(W360 X 39)	5 (127)	.420 (10.7)
W8 X 35	(W200 X 52)	8 (203)	.495 (12.6)	W14 X 30	(W360 X 44.8)	6 1/4 (171)	.385 (9.8)
W8 X 40	(W200 X 59)	8 1/16 (205)	.560 (14.2)	W14 X 34	(W360 X 51)	6 1/4 (171)	.455 (11.6)
W8 X 48	(W200 X 71)	8 1/8 (206)	.685 (17.4)	W14 X 38	(W360 X 57)	6 1/4 (171)	.515 (13.1)
W8 X 58	(W200 X 86)	8 1/4 (210)	.810 (20.6)	W14 X 43	(W360 X 64)	8 (203)	.530 (13.5)
W8 X 67	(W200 X 100)	8 1/4 (210)	.935 (23.7)	W14 X 48	(W360 X 72)	8 (203)	.595 (15.1)
W10 X 12	(W250 X 17.9)	4 (102)	.210 (5.3)	W14 X 53	(W360 X 79)	8 1/16 (205)	.660 (16.8)
W10 X 15	(W250 X 22.3)	4 (102)	.270 (6.9)	W14 X 61	(W360 X 91)	10 (254)	.645 (16.4)
W10 X 17	(W250 X 25.3)	4 (102)	.330 (8.4)	W14 X 68	(W360 X 101)	10 (254)	.720 (18.3)
W10 X 19	(W250 X 28.4)	4 (102)	.395 (10.0)	W14 X 74	(W360 X 110)	10 1/16 (256)	.785 (19.9)
W10 X 22	(W250 X 32.7)	5 1/4 (146)	.360 (9.1)	W14 X 82	(W360 X 122)	10 1/8 (257)	.855 (21.7)
W10 X 26	(W250 X 38.5)	5 1/4 (146)	.440 (11.2)	W14 X 90	(W360 X 134)	14 1/2 (368)	.710 (18.0)
W10 X 30	(W250 X 44.8)	5 3/16 (148)	.510 (13.0)	W14 X 99	(W360 X 147)	14 9/16 (370)	.780 (19.8)
W10 X 33	(W250 X 49.1)	7 1/16 (202)	.435 (11.0)	W14 X 109	(W360 X 162)	14 1/8 (371)	.860 (21.8)
W10 X 39	(W250 X 58)	8 (203)	.530 (13.5)	W14 X 120	(W360 X 179)	14 11/16 (373)	.940 (23.9)
W10 X 45	(W250 X 57)	8 (203)	.620 (15.7)	W14 X 132	(W360 X 196)	14 3/4 (375)	1.030 (26.2)
W10 X 49	(W250 X 73)	10 (254)	.560 (14.2)	W14 X 145	(W360 X 216)	15 1/2 (394)	1.090 (27.7)
W10 X 54	(W250 X 80)	10 1/16 (256)	.615 (15.6)	W14 X 159	(W360 X 237)	15 9/16 (395)	1.190 (30.2)
W10 X 60	(W250 X 89)	10 1/16 (256)	.680 (17.3)	W14 X 176	(W360 X 262)	15 5/8 (397)	1.310 (33.3)
W10 X 68	(W250 X 101)	10 1/8 (257)	.770 (19.6)	W14 X 193	(W360 X 287)	15 3/4 (400)	1.440 (36.6)
W10 X 77	(W250 X 115)	10 1/16 (259)	.870 (22.1)	W14 X 211	(W360 X 314)	15 3/4 (400)	1.560 (39.6)
W10 X 88	(W250 X 131)	10 1/4 (260)	.990 (25.1)	W14 X 233	(W360 X 347)	15 7/8 (403)	1.720 (43.7)
W10 X 100	(W250 X 149)	10 3/8 (264)	1.120 (28.4)	W14 X 257	(W360 X 382)	16 (406)	1.890 (48.0)
W10 X 112	(W250 X 167)	10 1/16 (265)	1.250 (31.8)	W14 X 283	(W360 X 421)	16 1/8 (410)	2.070 (52.6)
W12 X 14	(W310 X 21)	4 (102)	.225 (5.7)	W14 X 311	(W360 X 463)	16 1/4 (413)	2.260 (57.4)
W12 X 16	(W310 X 23.8)	4 (102)	.265 (6.7)	W14 X 342	(W360 X 509)	16 3/8 (416)	2.470 (62.7)
W12 X 19	(W310 X 28.3)	4 (102)	.350 (8.9)	W14 X 370	(W360 X 551)	16 1/2 (419)	2.660 (67.6)
W12 X 22	(W310 X 32.7)	4 (102)	.425 (10.8)	W14 X 398	(W360 X 592)	16 7/16 (421)	2.845 (72.3)
W12 X 26	(W310 X 38.7)	6 1/2 (165)	.380 (9.7)	W14 X 426	(W360 X 634)	16 11/16 (424)	3.035 (77.1)
W12 X 30	(W310 X 44.5)	6 1/2 (165)	.440 (11.2)	W16 X 26	(W410 X 38.8)	5 1/2 (140)	.345 (8.8)
W12 X 35	(W310 X 52)	6 9/16 (167)	.520 (13.2)	W16 X 31	(W410 X 46.1)	5 1/2 (140)	.440 (11.2)
W12 X 40	(W310 X 60)	8 (203)	.515 (13.1)	W16 X 36	(W410 X 53)	7 (178)	.430 (10.9)
W12 X 45	(W310 X 67)	8 1/16 (205)	.575 (14.6)	W16 X 40	(W410 X 60)	7 (178)	.505 (12.8)
W12 X 50	(W310 X 74)	8 1/16 (205)	.640 (16.3)	W16 X 45	(W410 X 67)	7 (178)	.565 (14.4)
W12 X 53	(W310 X 79)	10 (254)	.575 (14.6)	W16 X 50	(W410 X 75)	7 1/16 (179)	.630 (16.0)
W12 X 58	(W310 X 86)	10 (254)	.640 (16.3)	W16 X 57	(W410 X 85)	7 1/8 (181)	.715 (18.2)

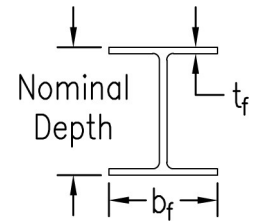

WIDE FLANGE I-BEAMS

Designation Nom. Depth & Weight		Flange Width b <sub>f</sub>	Flange Thickness t <sub>f</sub>
in. X lbs./ft	mm X kg/m		
W16 X 67	(W410 X 100)	10 1/4 (260)	.665 (16.9)
W16 X 77	(W410 X 114)	10 5/16 (262)	.760 (19.3)
W16 X 89	(W410 X 132)	10 3/8 (264)	.875 (22.2)
W16 X 100	(W410 X 149)	10 1/16 (265)	.985 (25.0)
W18 X 35	(W460 X 52)	6 (152)	.425 (10.8)
W18 X 40	(W460 X 60)	6 (152)	.525 (13.3)
W18 X 46	(W460 X 68)	6 1/16 (154)	.605 (15.4)
W18 X 50	(W460 X 74)	7 1/2 (191)	.570 (14.5)
W18 X 55	(W460 X 82)	7 1/2 (191)	.630 (16.0)
W18 X 60	(W460 X 89)	7 9/16 (192)	.695 (17.7)
W18 X 65	(W460 X 97)	7 7/8 (192)	.750 (19.1)
W18 X 71	(W460 X 106)	7 5/8 (194)	.810 (20.6)
W18 X 76	(W460 X 113)	11 (279)	.680 (17.3)
W18 X 86	(W460 X 128)	11 1/16 (281)	.770 (19.6)
W18 X 97	(W460 X 144)	11 1/8 (283)	.870 (22.1)
W18 X 106	(W460 X 158)	11 3/16 (284)	.940 (23.9)
W18 X 119	(W460 X 177)	11 1/4 (286)	1.060 (26.9)
W21 X 44	(W530 X 66)	6 1/2 (165)	.450 (11.4)
W21 X 50	(W530 X 74)	6 1/2 (165)	.535 (13.6)
W21 X 57	(W530 X 85)	6 9/16 (167)	.650 (16.5)
W21 X 62	(W530 X 92)	8 1/4 (210)	.615 (15.6)
W21 X 68	(W530 X 101)	8 1/4 (210)	.685 (17.4)
W21 X 73	(W530 X 109)	8 1/4 (210)	.740 (18.8)
W21 X 83	(W530 X 123)	8 1/8 (225)	.835 (21.2)
W21 X 93	(W530 X 138)	8 1/16 (214)	.930 (23.6)
W21 X 101	(W530 X 150)	12 1/4 (311)	.800 (20.3)
W21 X 111	(W530 X 165)	12 3/8 (314)	.875 (22.2)
W21 X 122	(W530 X 182)	12 1/16 (314)	.960 (24.4)
W21 X 132	(W530 X 196)	12 5/8 (316)	1.035 (26.3)
W21 X 147	(W530 X 219)	12 1/2 (318)	1.150 (29.2)
W24 X 55	(W610 X 82)	7 (178)	.505 (12.8)
W24 X 62	(W610 X 92)	7 1/16 (179)	.590 (15.0)
W24 X 68	(W610 X 101)	8 3/16 (227)	.585 (14.9)
W24 X 76	(W610 X 113)	9 (229)	.680 (17.3)
W24 X 84	(W610 X 125)	9 (229)	.770 (19.6)
W24 X 94	(W610 X 140)	9 1/16 (230)	.875 (22.2)
W24 X 104	(W610 X 155)	12 1/4 (324)	.750 (19.1)
W24 X 117	(W610 X 174)	12 1/4 (324)	.850 (21.6)
W24 X 131	(W610 X 195)	12 1/8 (327)	.960 (24.4)
W24 X 146	(W610 X 217)	12 1/8 (327)	1.090 (27.7)
W24 X 162	(W610 X 241)	12 5/16 (329)	1.220 (31.0)

Unless otherwise specified, all dimensions on drawings and in charts are in inches and dimensions shown in parentheses are in millimeters.

# TECHNICAL DATA



## STEEL PIPE DATA

Pipe Size	Schedule No.	O.D.		Wall Thickness		Weight				Pipe Size	Schedule No.	O.D.		Wall Thickness		Weight			
						Water		Pipe								Water		Pipe	
						lbs./ft	kg/m	lbs./ft	kg/m							lbs./ft	kg/m	lbs./ft	kg/m
3/8	10	0.675	(17.15)	.066	(1.68)	0.100	(0.15)	0.4325	(0.64)	5	(125)	5.563	(141.30)	0.134	(3.40)	9.55	(14.21)	7.77	(11.56)
	40			.091	(2.31)	0.083	(0.12)	0.567	(0.84)					0.258	(6.55)	8.67	(12.91)	14.62	(21.76)
	80			.126	(3.20)	0.061	(0.09)	0.738	(1.10)					0.375	(9.53)	7.89	(11.74)	20.78	(30.92)
1/2	10	0.84	(21.34)	.083	(2.11)	0.155	(0.23)	0.671	(1.00)	6	(150)	6.625	(168.28)	0.134	(3.40)	13.76	(20.48)	9.289	(13.82)
	40			.109	(2.77)	0.132	(0.20)	0.85	(1.26)					0.28	(7.11)	12.52	(18.64)	18.97	(28.23)
	80			.147	(3.73)	0.102	(0.15)	1.087	(1.62)					0.432	(10.97)	11.30	(16.82)	28.57	(42.52)
3/4	10	1.05	(26.67)	.083	(2.11)	0.266	(0.40)	0.8572	(1.28)	8	(200)	8.625	(219.08)	0.148	(3.76)	23.62	(35.15)	13.4	(19.94)
	40			.113	(2.87)	0.231	(0.34)	1.13	(1.68)					0.322	(8.18)	21.69	(32.28)	28.55	(42.49)
	80			.154	(3.91)	0.187	(0.28)	1.473	(2.19)					0.5	(12.70)	19.80	(29.46)	43.39	(64.57)
1	10	1.315	(33.40)	.109	(2.77)	0.410	(0.61)	1.404	(2.09)	10	(250)	10.75	(273.05)	0.165	(4.19)	36.97	(55.02)	18.7	(27.83)
	40			.133	(3.38)	0.375	(0.56)	1.678	(2.50)					0.365	(9.27)	34.19	(50.87)	40.48	(60.24)
	80			.179	(4.55)	0.312	(0.46)	2.171	(3.23)					0.593	(15.06)	31.14	(46.35)	64.4	(95.84)
1 1/4	10	1.66	(42.16)	.109	(2.77)	0.708	(1.05)	1.806	(2.69)	12	(300)	12.75	(323.85)	0.18	(4.57)	52.27	(77.79)	24.2	(36.01)
	40			.14	(3.56)	0.648	(0.96)	2.272	(3.38)					0.406	(10.31)	48.53	(72.21)	53.6	(79.77)
	80			.191	(4.85)	0.556	(0.83)	2.996	(4.46)					0.687	(17.45)	44.06	(65.57)	88.6	(131.85)
1 1/2	10	1.9	(48.26)	.109	(2.77)	0.963	(1.43)	2.085	(3.10)	14	(350)	14	(355.60)	0.25	(6.35)	62.05	(92.35)	36.71	(54.63)
	40			.145	(3.68)	0.883	(1.31)	2.717	(4.04)					0.437	(11.10)	58.66	(87.30)	63	(93.75)
	80			.2	(5.08)	0.766	(1.14)	3.631	(5.40)					0.75	(19.05)	53.20	(79.17)	107	(159.23)
2	10	2.375	(60.33)	.109	(2.77)	1.584	(2.36)	2.638	(3.93)	16	(400)	16	(406.40)	0.25	(6.35)	81.80	(121.74)	42.05	(62.58)
	40			.154	(3.91)	1.455	(2.16)	3.652	(5.43)					0.5	(12.70)	76.61	(114.01)	83	(123.52)
	80			.218	(5.54)	1.280	(1.91)	5.022	(7.47)					0.843	(21.41)	69.76	(103.82)	137	(203.88)
2 1/2	10	2.875	(73.03)	.12	(3.05)	2.364	(3.52)	3.531	(5.25)	18	(450)	18	(457.20)	0.25	(6.35)	104.27	(155.18)	47.39	(70.52)
	40			.203	(5.16)	2.076	(3.09)	5.79	(8.62)					0.563	(14.30)	96.95	(144.27)	105	(156.26)
	80			.276	(7.01)	1.837	(2.73)	7.66	(11.40)					0.937	(23.80)	88.54	(131.77)	171	(254.48)
3	10	3.5	(88.90)	.12	(3.05)	3.619	(5.39)	4.332	(6.45)	20	(500)	20	(508.00)	0.25	(6.35)	129.47	(192.67)	62.73	(93.35)
	40			.216	(5.49)	3.205	(4.77)	7.57	(11.27)					0.593	(15.06)	120.52	(179.36)	123	(183.04)
	80			.3	(7.62)	2.864	(4.26)	10.25	(15.25)					1.031	(26.19)	109.56	(163.04)	209	(311.03)
3 1/2	10	4	(101.60)	.12	(3.05)	4.814	(7.16)	4.973	(7.40)	24	(600)	24	(609.60)	0.25	(6.35)	188.04	(279.83)	63.41	(94.36)
	40			.318	(8.08)	3.853	(5.73)	12.51	(18.62)					0.687	(17.45)	174.31	(259.40)	171	(254.48)
	80			.318	(8.08)	3.853	(5.73)	12.51	(18.62)					1.218	(30.94)	158.33	(235.62)	297	(441.98)
4	10	4.5	(114.30)	.12	(3.05)	6.179	(9.20)	5.613	(8.35)	30	(750)	30	(762.00)	.5	(12.70)	286.00	(425.61)	158	(235.13)
	40			.237	(6.02)	5.519	(8.21)	10.79	(16.06)					.5	(12.70)	417.00	(620.56)	190	(282.75)
	80			.337	(8.56)	4.984	(7.42)	14.98	(22.29)										

## SPACING OF HANGERS FOR STEEL PIPE

Nominal Pipe Size	1/2	3/4	1	1 1/4	1 1/2	2	2 1/2	3	3 1/2	4	5	6	8	10	12	14	16	18	20	24	
	(15)	(20)	(25)	(32)	(40)	(50)	(65)	(80)	(90)	(100)	(125)	(150)	(200)	(250)	(300)	(350)	(400)	(450)	(500)	(600)	
Max. Span	7	7	7	7	9	10	11	12	13	14	16	17	19	22	23	25	27	28	30	32	
	(2.13)	(2.13)	(2.13)	(2.13)	(2.74)	(3.05)	(3.35)	(3.66)	(3.96)	(4.27)	(4.88)	(5.18)	(5.79)	(6.71)	(7.01)	(7.62)	(8.23)	(8.53)	(9.14)	(9.75)	
Recommended Hanger Rod Size	3/8	3/8	3/8	3/8	3/8	3/8	1/2	1/2	1/2	5/8	5/8	3/4	3/4	7/8	7/8	1	1	1	1 1/4	1 1/4	
																					OR TRAPEZE

**Note:** Spacing and capacities are based on pipe filled with water. Additional valves and fittings increase the load and therefore closer hanger spacing is required. Taken from ANSI/MSS SP-58.

**\*Many Codes and specifications require pipe hangers to be spaced every 10 ft (3.05m) regardless of size. Check local codes.**

# TECHNICAL DATA

## COPPER TUBE DATA

### TYPE L

Tube Size	Tubing O.D.		Wall Thickness		Weight				
					Water		Pipe		
					lbs./ft	kg/m	lbs./ft	kg/m	
1/4	(6)	.375	(9.53)	.030	(0.76)	.034	(.051)	.126	(.188)
3/8	(10)	.500	(12.70)	.035	(0.89)	.062	(.092)	.198	(.295)
1/2	(15)	.625	(15.88)	.040	(1.02)	.100	(.149)	.285	(.424)
5/8	(17)	.750	(19.05)	.042	(1.07)	.151	(.225)	.362	(.539)
3/4	(20)	.875	(22.23)	.045	(1.14)	.209	(.311)	.455	(.677)
1	(25)	1.125	(28.58)	.050	(1.27)	.357	(.531)	.655	(.975)
1 1/4	(32)	1.375	(34.93)	.055	(1.40)	.546	(.813)	.884	(1.316)
1 1/2	(40)	1.625	(41.28)	.060	(1.52)	.767	(1.141)	1.140	(1.697)
2	(50)	2.125	(53.98)	.070	(1.78)	1.341	(1.996)	1.750	(2.604)
2 1/2	(65)	2.625	(66.68)	.080	(2.03)	2.064	(3.072)	2.480	(3.691)
3	(80)	3.125	(79.38)	.090	(2.29)	2.949	(4.389)	3.330	(4.956)
3 1/2	(90)	3.625	(92.08)	.100	(2.54)	3.989	(5.936)	4.290	(6.384)
4	(100)	4.125	(104.78)	.110	(2.79)	5.188	(7.721)	5.380	(8.006)
5	(125)	5.125	(130.18)	.125	(3.18)	8.081	(12.026)	7.610	(11.325)
6	(150)	6.125	(155.58)	.140	(3.56)	11.616	(17.287)	10.200	(15.179)
8	(200)	8.125	(206.38)	.200	(5.08)	20.289	(30.193)	19.260	(28.662)
10	(250)	10.125	(257.18)	.250	(6.35)	31.590	(47.011)	30.100	(44.794)
12	(300)	12.125	(307.98)	.280	(7.11)	45.426	(67.601)	40.400	(60.122)

### TYPE K

Tube Size	Tubing O.D.		Wall Thickness		Weight				
					Water		Pipe		
					lbs./ft	kg/m	lbs./ft	kg/m	
1/4	(6)	.375	(9.53)	.035	(0.89)	.032	(.048)	.145	(.216)
3/8	(10)	.500	(12.70)	.049	(1.24)	.055	(.082)	.269	(.400)
1/2	(15)	.625	(15.88)	.049	(1.24)	.094	(.140)	.344	(.512)
5/8	(17)	.750	(19.05)	.049	(1.24)	.144	(.214)	.418	(.622)
3/4	(20)	.875	(22.23)	.065	(1.65)	.188	(.280)	.641	(.954)
1	(25)	1.125	(28.58)	.065	(1.65)	.337	(.502)	.839	(1.249)
1 1/4	(32)	1.375	(34.93)	.065	(1.65)	.527	(.784)	1.040	(1.548)
1 1/2	(40)	1.625	(41.28)	.072	(1.83)	.743	(1.106)	1.360	(2.024)
2	(50)	2.125	(53.98)	.083	(2.11)	1.310	(1.949)	2.060	(3.066)
2 1/2	(65)	2.625	(66.68)	.095	(2.41)	2.000	(2.976)	2.920	(4.345)
3	(80)	3.125	(79.38)	.109	(2.77)	2.960	(4.405)	4.000	(5.953)
3 1/2	(90)	3.625	(92.08)	.120	(3.05)	3.900	(5.804)	5.120	(7.619)
4	(100)	4.125	(104.78)	.134	(3.40)	5.060	(7.530)	6.510	(9.688)
5	(125)	5.125	(130.18)	.160	(4.06)	8.000	(11.905)	9.670	(14.391)
6	(150)	6.125	(155.58)	.192	(4.88)	11.200	(16.667)	13.870	(20.641)
8	(200)	8.125	(206.38)	.271	(6.88)	19.500	(29.019)	25.900	(38.543)
10	(250)	10.125	(257.18)	.338	(8.59)	30.423	(45.274)	40.300	(59.973)
12	(300)	12.125	(307.98)	.405	(10.29)	43.675	(64.996)	57.800	(86.016)

## SPACING OF HANGERS FOR COPPER TUBING

Tubing Size	1/2	3/4	1	1 1/4	1 1/2	2	2 1/2	3	3 1/2	4	5	6	8	10	12	
	(15)	(20)	(25)	(32)	(40)	(50)	(65)	(80)	(90)	(100)	(125)	(150)	(200)	(250)	(300)	
Span	ft	5	5	6	7	8	8	9	10	11	12	13	14	16	18	19
	m	(1.5)	(1.5)	(1.8)	(2.1)	(2.4)	(2.4)	(2.7)	(3.0)	(3.4)	(3.7)	(4.0)	(4.3)	(4.9)	(5.5)	(5.8)

**Note:** Spacing and capacities are based on pipe filled with water. Additional valves and fittings increase the load and therefore closer hanger spacing is required. Taken from ANSI/MSS SP-58.

## AWWA DUCTILE IRON PIPE DATA

Nominal Pipe Size	Class	O.D. D.I. Pipe		Wall Thick	Weight					
					Pipe		Water			
					lbs./ft	kg/m	lbs./ft	kg/m		
3	(80)	53	3.96	(100.58)	.31	(7.87)	11.2	(16.67)	3.8	(5.66)
4	(100)	53	4.80	(121.92)	.32	(8.13)	14.2	(21.13)	5.9	(8.78)
6	(150)	53	6.90	(175.26)	.34	(8.64)	22.0	(32.74)	13.1	(19.49)
8	(200)	53	9.05	(229.87)	.36	(9.14)	31.0	(46.13)	23.0	(34.23)
10	(250)	53	11.1	(281.94)	.38	(9.65)	40.4	(60.12)	36.4	(54.17)
12	(300)	53	13.2	(335.28)	.40	(10.16)	50.7	(75.45)	52.3	(77.83)
14	(350)	53	15.3	(388.62)	.42	(10.67)	62.4	(92.86)	71.1	(105.81)
16	(400)	53	17.4	(441.96)	.43	(10.92)	72.8	(108.34)	93.1	(138.55)
18	(450)	53	19.5	(495.30)	.44	(11.18)	83.6	(124.41)	117.9	(175.45)
20	(500)	53	21.6	(548.64)	.45	(11.43)	95.2	(141.67)	145.8	(216.97)
24	(600)	53	25.8	(655.32)	.47	(11.94)	119.2	(177.39)	210.2	(312.81)
30	(750)	53	32.0	(812.80)	.51	(12.95)	161.3	(240.04)	326.5	(485.89)
36	(900)	53	38.3	(972.82)	.58	(14.73)	219.5	(326.65)	469.3	(698.40)
42	(1050)	53	44.5	(1130.30)	.65	(16.51)	285.2	(424.42)	634.9	(944.84)
48	(1200)	53	50.8	(1290.32)	.72	(18.29)	360.3	(536.19)	828.9	(1233.54)

Based on AWWA C108-70, Table 8.2.  
Add flange weight for flanged cast iron pipe.

## GLASS PIPE DATA

### REGULAR SCHEDULE

Nominal Pipe Size	O.D. D.I. Pipe	Wall Thick		Weight					
				Pipe		Water			
				lbs./ft	kg/m	lbs./ft	kg/m		
1 1/2	(40)	1.84	(46.74)	.12	(3.05)	.64	(.95)	.89	(1.32)
2	(50)	2.34	(59.44)	.14	(3.56)	.94	(1.40)	1.45	(2.16)
3	(80)	3.41	(86.61)	.17	(4.32)	1.60	(2.38)	3.19	(4.75)
4	(100)	4.53	(115.06)	.20	(5.08)	2.60	(3.87)	5.79	(8.62)
6	(150)	6.66	(169.16)	.24	(6.10)	4.70	(6.99)	12.78	(19.02)

### HEAVY SCHEDULE

1	(25)	1.31	(33.27)	.16	(4.06)	.60	(.89)	.35	(.52)
1 1/2	(40)	1.84	(46.74)	.17	(4.32)	.87	(1.29)	.76	(1.13)
2	(50)	2.34	(59.44)	.17	(4.32)	1.10	(1.64)	1.36	(2.02)
3	(80)	3.41	(86.61)	.20	(5.08)	2.00	(2.98)	3.06	(4.55)
4	(100)	4.53	(115.06)	.26	(6.60)	3.40	(5.06)	5.44	(8.10)
6	(150)	6.66	(169.16)	.33	(8.38)	6.30	(9.38)	12.42	(18.48)

Spacing of Hangers for glass pipe support every 8-10 ft (2.44 - 3.05 m). Pad all hangers. Use only clevis or trapeze, do not tie down pipe.

# TECHNICAL DATA



## PVC PLASTIC PIPE DATA

Pipe Size		Sch. No.	O.D.		Wall Thickness		Weight				Pipe Size		Sch. No.	O.D.		Wall Thickness		Weight			
							Water		Pipe									Water		Pipe	
							lbs./ft	kg/m	lbs./ft	kg/m								lbs./ft	kg/m	lbs./ft	kg/m
1/8	(3)	40	.405	(10.3)	.068	(1.73)	.025	(.037)	.043	(.064)	2 1/2	(65)	40	2.875	(73.03)	.203	(5.16)	2.072	(3.08)	1.020	(1.518)
		80			.095	(2.41)	.016	(.024)	.055	(.082)						.276	(7.01)	1.834	(2.73)	1.350	(2.009)
1/4	(6)	40	.540	(13.7)	.088	(2.24)	.045	(.067)	.074	(.110)	3	(80)	40	3.500	(88.9)	.216	(5.49)	3.20	(4.76)	1.333	(1.984)
		80			.119	(3.02)	.031	(.046)	.094	(.140)						.300	(7.62)	2.86	(4.26)	1.804	(2.685)
3/8	(10)	40	.675	(17.15)	.091	(2.31)	.083	(.124)	.100	(.149)	3 1/2	(90)	40	4.000	(101.6)	.226	(5.74)	4.28	(6.37)	1.598	(2.378)
		80			.126	(3.20)	.061	(.091)	.129	(.192)						.318	(8.08)	3.85	(5.73)	2.195	(3.267)
1/2	(15)	40	.840	(21.34)	.109	(2.77)	.132	(.196)	.150	(.223)	4	(100)	40	4.500	(114.3)	.237	(6.02)	5.51	(8.20)	1.899	(2.826)
		80			.147	(3.73)	.101	(.150)	.200	(.298)						.337	(8.56)	4.98	(7.41)	2.636	(3.923)
3/4	(20)	40	1.050	(26.67)	.113	(2.87)	.230	(.342)	.199	(.296)	5	(125)	40	5.563	(141.30)	.258	(6.55)	8.66	(12.89)	2.770	(4.122)
		80			.154	(3.91)	.186	(.277)	.259	(.385)						.375	(9.53)	7.87	(11.71)	4.126	(6.140)
1	(25)	40	1.315	(33.40)	.133	(3.38)	.374	(.557)	.295	(.439)	6	(150)	40	6.625	(168.28)	.280	(7.11)	12.51	(18.62)	3.339	(4.969)
		80			.179	(4.55)	.311	(.463)	.382	(.568)						.432	(10.97)	11.92	(17.74)	5.028	(7.482)
1 1/4	(32)	40	1.660	(42.16)	.140	(3.56)	.647	(.963)	.400	(.595)	8	(200)	40	8.625	(219.08)	.322	(8.18)	21.60	(32.14)	5.280	(7.858)
		80			.191	(4.85)	.555	(.826)	.527	(.784)						.500	(12.70)	19.80	(29.47)	8.023	(11.940)
1 1/2	(40)	40	1.900	(48.26)	.145	(3.68)	.882	(1.313)	.479	(.713)	10	(250)	40	10.75	(273.05)	.365	(9.27)	34.10	(50.75)	7.505	(11.169)
		80			.200	(5.08)	.765	(1.138)	.639	(.951)						.593	(15.06)	31.10	(46.28)	11.894	(17.700)
2	(50)	40	2.375	(60.33)	.154	(3.91)	1.452	(2.161)	.643	(.957)	12	(300)	40	12.75	(323.85)	.406	(10.31)	48.50	(72.18)	10.023	(14.916)
		80			.218	(5.54)	1.279	(1.903)	.884	(1.316)						.687	(17.45)	44.00	(65.48)	16.365	(24.354)

## SPACING OF HANGERS FOR PVC PLASTIC PIPE

Schedule 40 Pipe Size	Support Spacing																			
	Temperature																			
	20°F (-6.6°C)		40°F (4.4°C)		60°F (15.6°C)		80°F (26.7°C)		100°F (37.8°C)		110°F (43.3°C)		120°F (48.9°C)		130°F (54.4°C)		140°F (60°C)		150°F (65.6°C)	
	ft	m	ft	m	ft	m	ft	m	ft	m	ft	m	ft	m	ft	m	ft	m	ft	m
1/2 - 3/4 (15-20)	5.00	(1.52)	4.75	(1.45)	4.50	(1.37)	4.25	(1.30)	4.00	(1.22)	3.75	(1.14)	3.33	(1.01)	3.00	(.91)	2.66	(.81)	2.00	(.61)
1 - 1 1/4 (25-32)	5.50	(1.68)	5.25	(1.60)	5.00	(1.52)	4.66	(1.42)	4.33	(1.32)	4.00	(1.22)	3.75	(1.14)	3.33	(1.01)	2.80	(.85)	2.25	(.69)
1 1/2 - 2 (40-50)	5.80	(1.77)	5.50	(1.68)	5.25	(1.60)	5.00	(1.52)	4.66	(1.42)	4.33	(1.32)	3.80	(1.16)	3.50	(1.07)	3.00	(.91)	2.50	(.76)
2 1/2 (65)	6.66	(2.03)	6.33	(1.93)	6.00	(1.83)	5.50	(1.68)	5.25	(1.60)	4.80	(1.46)	4.50	(1.37)	4.00	(1.22)	3.50	(1.07)	2.80	(.85)
3 (80)	6.80	(2.07)	6.50	(1.98)	6.25	(1.91)	5.80	(1.77)	5.50	(1.68)	5.25	(1.60)	4.75	(1.45)	4.25	(1.30)	3.66	(1.12)	3.00	(.91)
4 (100)	7.33	(2.23)	7.00	(2.13)	6.50	(1.98)	6.25	(1.91)	5.80	(1.77)	5.50	(1.68)	5.00	(1.52)	4.50	(1.37)	3.80	(1.16)	3.25	(.99)
6 (150)	7.80	(2.38)	7.50	(2.29)	7.00	(2.13)	6.80	(2.07)	6.33	(1.93)	5.80	(1.77)	5.33	(1.62)	4.80	(1.46)	4.25	(1.30)	3.50	(1.07)

Schedule 80 Pipe Size	Support Spacing																			
	Temperature																			
	20°F (-6.6°C)		40°F (4.4°C)		60°F (15.6°C)		80°F (26.7°C)		100°F (37.8°C)		110°F (43.3°C)		120°F (48.9°C)		130°F (54.4°C)		140°F (60°C)		150°F (65.6°C)	
	ft	m	ft	m	ft	m	ft	m	ft	m	ft	m	ft	m	ft	m	ft	m	ft	m
1/2 - 3/4 (15-20)	5.75	(1.75)	5.50	(1.68)	5.25	(1.60)	4.80	(1.46)	4.50	(1.37)	4.33	(1.32)	3.80	(1.16)	3.50	(1.07)	3.00	(.91)	2.50	(.76)
1 (25)	6.33	(1.93)	6.00	(1.83)	5.75	(1.75)	5.33	(1.62)	5.00	(1.52)	4.60	(1.40)	4.33	(1.32)	3.80	(1.16)	3.33	(1.01)	2.75	(.84)
1 1/4 - 1 1/2 (32-40)	6.66	(2.03)	6.33	(1.93)	6.00	(1.83)	5.66	(1.73)	5.25	(1.60)	4.80	(1.46)	4.50	(1.37)	4.00	(1.22)	3.50	(1.07)	3.00	(.91)
2 (50)	7.00	(2.13)	6.50	(1.98)	6.25	(1.91)	6.00	(1.83)	5.50	(1.68)	5.12	(1.56)	4.75	(1.45)	4.33	(1.32)	3.66	(1.12)	3.12	(.95)
2 1/2 (65)	7.80	(2.38)	7.50	(2.29)	7.00	(2.13)	6.66	(2.03)	6.33	(1.93)	5.80	(1.77)	5.33	(1.62)	4.75	(1.45)	4.25	(1.30)	3.33	(1.01)
3 (80)	8.20	(2.50)	7.75	(2.36)	7.33	(2.23)	7.00	(2.13)	6.50	(1.98)	6.00	(1.83)	5.50	(1.68)	5.00	(1.52)	4.33	(1.32)	3.50	(1.07)
4 (100)	8.66	(2.64)	8.25	(2.51)	7.80	(2.38)	7.33	(2.23)	6.80	(2.07)	6.33	(1.93)	5.80	(1.77)	5.25	(1.60)	4.66	(1.42)	3.75	(1.14)
6 (150)	9.80	(2.99)	9.33	(2.84)	8.80	(2.68)	8.33	(2.54)	7.80	(2.38)	7.33	(2.23)	6.50	(1.98)	6.00	(1.83)	5.12	(1.56)	4.25	(1.30)

Unless otherwise specified, all dimensions on drawings and in charts are in inches and dimensions shown in parentheses are in millimeters.

# TECHNICAL DATA

## CONDUIT DATA

### ELECTRICAL METALLIC TUBING DATA

### STEEL RIGID CONDUIT DATA

Nominal Size EMT Conduit	O.D. Conduit		Weight Conduit W/C Plg.		Approx. Max. Weight Conduit And Conductor				Nominal Size EMT Conduit	O.D. Conduit		O.D. Coupling		Weight Conduit W/C Plg.		Approx. Max. Weight Conduit And Conductor			
					Not Lead Covered											Lead Covered		Not Lead Covered	
					lbs./ft	kg/m	lbs./ft	kg/m											
1/2	(15)	.706	(17.93)	.29	(0.43)	.54	(0.80)	1/2	(15)	.840	(21.34)	1.010	(25.65)	.80	(1.19)	1.17	(1.74)	1.04	(1.55)
3/4	(20)	.922	(23.42)	.45	(0.67)	1.16	(1.73)	3/4	(20)	1.050	(26.67)	1.250	(31.75)	1.09	(1.62)	1.75	(2.60)	1.40	(2.08)
1	(25)	1.163	(29.54)	.65	(0.97)	1.83	(2.72)	1	(25)	1.315	(33.40)	1.525	(38.74)	1.65	(2.46)	2.62	(3.90)	2.35	(3.50)
1 1/4	(32)	1.510	(38.35)	.96	(1.43)	2.96	(4.40)	1 1/4	(32)	1.660	(42.16)	1.869	(47.47)	2.15	(3.20)	4.31	(6.41)	3.58	(5.33)
1 1/2	(40)	1.740	(44.20)	1.11	(1.65)	3.68	(5.48)	1 1/2	(40)	1.900	(48.26)	2.155	(54.74)	2.58	(3.84)	5.89	(8.77)	4.55	(6.77)
2	(50)	2.197	(55.80)	1.41	(2.10)	4.45	(6.62)	2	(50)	2.375	(60.33)	2.650	(67.31)	3.52	(5.24)	8.53	(12.69)	7.21	(10.73)
2 1/2	(65)	2.875	(73.03)	2.15	(3.20)	6.41	(9.54)	2 1/2	(65)	2.875	(73.03)	3.250	(82.55)	5.67	(8.44)	11.51	(17.13)	10.22	(15.21)
3	(80)	3.500	(88.90)	2.60	(3.87)	9.30	(13.84)	3	(80)	3.500	(88.90)	3.870	(98.30)	7.14	(10.63)	16.51	(24.57)	14.51	(21.59)
3 1/2	(90)	4.000	(101.60)	3.25	(4.84)	12.15	(18.08)	3 1/2	(90)	4.000	(101.60)	4.500	(114.30)	8.60	(12.80)	19.05	(28.35)	17.49	(26.03)
4	(100)	4.500	(114.30)	3.90	(5.80)	15.40	(22.92)	4	(100)	4.500	(114.30)	4.875	(123.83)	10.00	(14.88)	24.75	(36.83)	21.48	(31.97)
								5	(125)	5.563	(141.30)	6.000	(152.40)	13.20	(19.64)	35.87	(53.38)	30.83	(45.88)
								6	(150)	6.625	(168.28)	7.200	(182.88)	17.85	(26.56)	50.69	(75.44)	43.43	(64.63)

**Note:** 2 1/2" through 4" EMT is the same as steel rigid conduit

### INTERMEDIATE METAL CONDUIT DATA

Nominal Size EMT Conduit	O.D. Conduit		O.D. Coupling		Weight Conduit W/C Plg.		Approx. Max. Weight Conduit And Conductor				
							Lead Covered		Not Lead Covered		
							lbs./ft	kg/m	lbs./ft	kg/m	lbs./ft
1/2	(15)	.815	(20.70)	1.010	(25.65)	.60	(0.89)	.97	(1.44)	.84	(1.25)
3/4	(20)	1.029	(26.14)	1.250	(31.75)	.82	(1.22)	1.48	(2.20)	1.13	(1.68)
1	(25)	1.290	(32.77)	1.525	(38.74)	1.16	(1.73)	2.13	(3.17)	1.86	(2.77)
1 1/4	(32)	1.638	(41.61)	1.869	(47.47)	1.50	(2.23)	3.66	(5.45)	2.93	(4.36)
1 1/2	(40)	1.883	(47.83)	2.155	(54.74)	1.82	(2.71)	5.13	(7.63)	3.79	(5.64)
2	(50)	2.360	(59.94)	2.650	(67.31)	2.42	(3.60)	7.43	(11.06)	6.11	(9.09)
2 1/2	(65)	2.857	(72.57)	3.250	(82.55)	4.28	(6.37)	10.12	(15.06)	8.83	(13.14)
3	(80)	3.476	(88.29)	3.870	(98.30)	5.26	(7.83)	14.63	(21.77)	12.63	(18.80)
3 1/2	(90)	3.971	(100.86)	4.500	(114.30)	6.12	(9.11)	16.57	(24.66)	15.01	(22.34)
4	(100)	4.466	(113.44)	4.875	(123.83)	6.82	(10.15)	21.57	(32.10)	18.30	(27.23)

## THREADED ROD DATA

Nominal Rod Dia.	Root Area Thread		Max. Rec. Load			
			650°F (343°C)		750°F (399°C)	
	in. <sup>2</sup>	mm <sup>2</sup>	lbs.	kN	lbs.	kN
1/4	.027	(17.42)	240	(1.07)	210	(0.93)
3/8	.068	(43.87)	730	(3.25)	572	(2.54)
1/2	.126	(81.29)	1350	(6.01)	1057	(4.70)
5/8	.202	(130.32)	2160	(9.61)	1692	(7.53)
3/4	.302	(194.84)	3230	(14.37)	2530	(11.25)
7/8	.419	(270.32)	4480	(19.93)	3508	(15.60)
1	.552	(356.13)	5900	(26.24)	4620	(20.55)
1 1/8	.693	(447.10)	7450	(33.14)	5830	(25.93)
1 1/4	.889	(573.55)	9500	(42.26)	7440	(33.09)
1 1/2	1.293	(834.19)	13800	(61.39)	10807	(48.07)
1 3/4	1.744	(1125.16)	18600	(82.74)	14566	(64.79)
2	2.300	(1483.87)	24600	(109.43)	19625	(87.30)
2 1/4	3.023	(1950.32)	32300	(143.68)	25295	(112.52)
2 1/2	3.719	(2399.35)	39800	(177.04)	31169	(138.65)

Unless otherwise specified, all dimensions on drawings and in charts are in inches and dimensions shown in parentheses are in millimeters.



# TECHNICAL DATA



## CAST IRON PIPE DATA

### SERVICE WEIGHT CAST IRON SOIL PIPE DATA (BELL & SPIGOT TYPE)

Nominal Pipe Size		O.D. of Cast Iron Pipe		Wall Thickness		Weight			
						Pipe		Water	
						lbs./ft	kg/m	lbs./ft	kg/m
2	(50)	2.25	(57.15)	.17	(4.32)	4.00	(5.95)	1.24	(1.85)
3	(80)	3.25	(82.55)	.17	(4.32)	6.00	(8.93)	2.88	(4.29)
4	(100)	4.25	(107.95)	.18	(4.57)	8.00	(11.91)	5.15	(7.66)
5	(125)	5.25	(133.35)	.18	(4.57)	10.40	(15.48)	8.14	(12.11)
6	(150)	6.25	(158.75)	.18	(4.57)	13.00	(19.35)	11.80	(17.57)
8	(200)	8.38	(212.85)	.23	(5.84)	20.00	(29.76)	21.34	(31.76)
10	(250)	10.50	(266.70)	.28	(7.11)	29.00	(43.16)	33.62	(50.03)
12	(300)	12.50	(317.50)	.28	(7.11)	38.00	(56.55)	48.51	(72.18)
15	(380)	15.62	(396.75)	.31	(7.87)	51.00	(75.90)	76.55	(113.92)

### EXTRA WEIGHT CAST IRON SOIL PIPE DATA (BELL & SPIGOT TYPE)

Nominal Pipe Size		O.D. of Cast Iron Pipe		Wall Thickness		Weight			
						Pipe		Water	
						lbs./ft	kg/m	lbs./ft	kg/m
2	(50)	2.38	(60.45)	.190	(4.83)	5.00	(7.44)	1.36	(2.03)
3	(80)	3.50	(88.90)	.250	(6.35)	9.00	(13.39)	3.06	(4.56)
4	(100)	4.50	(114.30)	.250	(6.35)	12.00	(17.86)	5.44	(8.10)
5	(125)	5.50	(139.70)	.250	(6.35)	15.00	(22.32)	8.51	(12.66)
6	(150)	6.50	(165.10)	.250	(6.35)	19.00	(28.28)	12.25	(18.23)
8	(200)	8.62	(218.95)	.310	(7.87)	30.00	(44.64)	21.78	(32.40)
10	(250)	10.75	(273.05)	.375	(9.53)	43.00	(63.99)	34.02	(50.63)
12	(300)	12.75	(323.85)	.375	(9.53)	54.00	(80.36)	48.99	(72.91)
15	(380)	15.88	(403.35)	.440	(11.18)	75.00	(111.61)	76.55	(113.92)

### NO HUB CAST IRON SOIL PIPE DATA

Nominal Pipe Size		O.D. of Cast Iron Pipe		Wall Thickness		Weight			
						Pipe		Water	
						lbs./ft	kg/m	lbs./ft	kg/m
1½	(40)	1.90	(48.26)	.16	(4.06)	2.70	(4.02)	0.85	(1.26)
2	(50)	2.35	(59.69)	.16	(4.06)	3.60	(5.36)	1.40	(2.09)
3	(80)	3.35	(85.09)	.16	(4.06)	5.20	(7.74)	3.12	(4.65)
4	(100)	4.38	(111.25)	.19	(4.83)	7.40	(11.01)	5.44	(8.10)
5	(125)	5.30	(134.62)	.19	(4.83)	9.60	(14.29)	8.24	(12.26)
6	(150)	6.30	(160.02)	.19	(4.83)	11.00	(16.37)	11.92	(17.74)
8	(200)	8.38	(212.85)	.23	(5.84)	18.00	(26.79)	21.34	(31.76)
10	(250)	10.50	(266.70)	.28	(7.11)	26.20	(38.99)	33.62	(50.03)
12	(300)	12.50	(317.50)	.28	(7.11)	35.50	(52.83)	48.51	(72.18)

Unless otherwise specified, all dimensions on drawings and in charts are in inches and dimensions shown in parentheses are in millimeters.

# TECHNICAL DATA

## CONVERSION FACTORS FOR UNITS OF MEASUREMENT

To Convert From	To	Multiply By
Length		
Inch	Millimeter	25.4
Feet	Meter	0.3048
Yard	Meter	0.9144
Mile	Kilometer	1.6093
Area		
Square Inch	Square Millimeter	645.16
Square Feet	Square Meter	0.0929
Square Yard	Square Meter	0.8361
Square Mile	Square Kilometer	2.5899
Volume		
Gallon	Liter	3.7854
Quart	Liter	0.9463
Cubic Inch	Cubic Millimeter	16,387.06
Cubic Feet	Cubic Meter	0.0283
Cubic Yard	Cubic Meter	0.76455
Mass		
Ounce	Gram	28.3495
Pound	Kilogram	0.45359
Short Ton	Kilogram	907.185
Force		
Ounce-Force	Newton	0.278014
Pound-Force	Newton	4.44822
Pressure		
Pound - Force / Square Inch	Kilopascal	6.894757
Foot of Water (39.2°F)	Kilopascal	2.98898
Inch of Mercury (32°F)	Kilopascal	3.38638
Bending Moment		
Pound - Force - Inch	Newton - Meter	0.112985
Pound - Force - Foot	Newton - Meter	1.355818
Energy, Work, & Heat		
Foot - Pound - Force	Joule	1.355818
British Thermal Unit (BTU)	Joule	1,055.056
Calorie	Joule	4.1868
Kilowatt Hour	Joule	3,600,000
Power		
Foot - Pound - Force / Second	Watt	1.355818
British Thermal Unit / Hour	Watt	0.29307
Horsepower	Kilowatt	0.7457
Temperature		
Degree Fahrenheit	Degree Celsius	$\frac{(F^{\circ} - 32)}{1.8}$

To Convert From	To	Multiply By
Length		
Millimeter	Inch	0.03937
Meter	Feet	3.28084
Meter	Yard	1.09361
Kilometer	Mile	0.62137
Area		
Square Millimeter	Square Inch	0.001550
Square Meter	Square Feet	10.7639
Square Meter	Square Yard	1.19599
Square Kilometer	Square Mile	0.3861
Volume		
Liter	Gallon	0.26417
Liter	Quart	1.05669
Cubic Millimeter	Cubic Inch	0.000061
Cubic Meter	Cubic Feet	35.31466
Cubic Meter	Cubic Yard	1.30795
Mass		
Gram	Ounce	0.035274
Kilogram	Pound	2.20462
Kilogram	Short Ton	0.0011
Force		
Newton	Ounce-Force	3.59694
Newton	Pound-Force	0.22481
Pressure		
Kilopascal	Pound - Force / Square Inch	0.145038
Kilopascal	Foot of Water (39.2°F)	0.334562
Kilopascal	Inch of Mercury (32°F)	0.295301
Bending Moment		
Newton - Meter	Pound - Force - Inch	8.85073
Newton - Meter	Pound - Force - Foot	0.73756
Energy, Work, & Heat		
Joule	Foot - Pound - Force	0.73756
Joule	British Thermal Unit (BTU)	0.000948
Joule	Calorie	0.23884
Joule	Kilowatt Hour	2.78e-7
Power		
Watt	Foot - Pound - Force / Second	0.73756
Watt	British Thermal Unit / Hour	3.41214
Kilowatt	Horsepower	1.341022
Temperature		
Degree Celsius	Degree Fahrenheit	1.8 C° + 32

Unless otherwise specified, all dimensions on drawings and in charts are in inches and dimensions shown in parentheses are in millimeters.

# COMPLIANCES & APPROVALS



Figure Number	ANSI/MSS SP-58	Federal Spec A-A-1192A	U.S. (UL) Listed	CAN. (CUL) Listed	FM Approved	Buy American	100% Domestic
010			1"x1" - 4" 1 1/4"x1" - 6"	1"x1" - 4" 1 1/4"x1" - 6"	1"x1" - 4" 1 1/4"x1" - 6"		
015			1"x2 1/2" - 6" 1 1/4"x2 1/2" - 6"	1"x2 1/2" - 6" 1 1/4"x2 1/2" - 6"	1"x2 1/2" - 8" 1 1/4"x2 1/2" - 8"		
020			3/8"	3/8"			
025			1/2" & 3/4"	1/2" & 3/4"		1/2" & 3/4"	1/2" & 3/4"
030			1" - 8"	1" - 8"	1" - 8"	1" - 8"	1" - 8"
031			2" - 8"	2" - 8"	2" - 8"	2" - 8"	2" - 8"
035			1" - 8"	1" - 8"	1" - 8"	1" - 8"	1" - 8"
040			2" - 8"	2" - 8"	2" - 8"	2" - 8"	2" - 8"
045			1" - 8"	1" - 8"	1" - 8"	1" - 8"	1" - 8"
055			3/4" - 2"	3/4" - 2"			
070			3/4" - 2"	3/4" - 2"		3/4" - 2"	
075			3/4" - 2"	3/4" - 2"		3/4" - 2"	
076			3/4" - 2"	3/4" - 2"		3/4" - 2"	
077			3/4" - 2"	3/4" - 2"		3/4" - 2"	
10						3/8" - 7/8"	3/8" - 7/8"
15 & 15L						3/8" - 1"	3/8" - 1"
20 & 21						1/4" - 1"	1/4" - 1"
25							
30	Type 16	Type 16					
35 & 35L	Type 17	Type 17				3/8" - 1 1/2"	3/8" - 1 1/2"
36			3/8"	3/8"	3/8"		
37			3/8" & 1/2"	3/8" & 1/2"	3/8"		
38	Type 14	Type 14				#2 - #7	#2 - #7
40							
41						5/8" - 1"	5/8" - 1"
47S						3/8" - 5/8"	3/8" - 5/8"
47W						3/8" - 5/8"	3/8" - 5/8"
48							
50 & 50L						3/8" - 1"	3/8" - 1"
55 & 55L						3/8" - 1"	3/8" - 1"
90	Type 24	Type 24				1/2" - 36"	1/2" - 36"
91	Type 24	Type 24				1/2" - 36"	1/2" - 36"
93	Type 24	Type 24				1/2" - 36"	1/2" - 36"
94	Type 24	Type 24				1/2" - 36"	1/2" - 36"
95						1/2" - 10"	1/2" - 10"
100						1/4" - 1"	1/4" - 1"
104						3/8" & 1/2"	3/8" & 1/2"
105						3/8" - 7/8"	3/8" - 7/8"
110 & 110H						1/4" - 1 1/2"	1/4" - 1 1/2"
130						1/4" - 1 1/2"	1/4" - 1 1/2"
134						3/8" - 3/4"	3/8" - 3/4"
135						3/8" - 7/8"	3/8" - 7/8"
136						3/8" & 1/2"	3/8" & 1/2"
141 & 141F	Type 10	Type 10	3/4" - 8"	3/4" - 8"	3/4" - 8"	1/2" - 8"	
143	Type 10	Type 10	3/4" - 8"	3/4" - 8"	3/4" - 8"	1/2" - 8"	
151 & 151F	Type 10	Type 10	2 1/2" - 8"	2 1/2" - 8"	2 1/2" - 8"	2 1/2" - 8"	
152 & 154	Type 10	Type 10					

Due to a mix of stock, you must specify "Buy American" or "100% Domestic" when ordering to ensure the material you receive is in compliance.

# COMPLIANCES & APPROVALS

Figure Number	ANSI/MSS SP-58	Federal Spec A-A-1192A	U.S. (UL) Listed	CAN. (CUL) Listed	FM Approved	Buy American	100% Domestic
145 & 155						#1 - #12	#1 - #12
160						#1 - #24	#1 - #24
165						0505 - 5010	0505 - 5010
166						6205 - 41215	6205 - 41215
167						1230 - 16030	1230 - 16030
168						16230 - 41230	16230 - 41230
170	Type 40	Type 40				#1A - #30E	#1A - #30E
180 & 180F	Type 7	Type 7				1/2" - 8"	1/2" - 8"
181	Type 7	Type 7				1/2" - 8"	1/2" - 8"
182	Type 7	Type 7				1/2" - 4"	1/2" - 4"
TRH 2 - TRH 5							
250	Type 23	Type 23	3/8" & 1/2"	3/8" & 1/2"	3/8"	3/8" & 1/2"	3/8" & 1/2"
259						#1 & #2	#1 & #2
270	Type 23	Type 23					
290	Type 23	Type 23	3/8"	3/8"	3/8"		
345	Type 19	Type 19	3/8"	3/8"	3/8"	3/8"	3/8"
350	Type 19 & 23	Type 19 & 23	1/2" - 7/8"	1/2" - 7/8"	1/2"		
350 (1/4")	Type 19	Type 19				1/4"	1/4"
353	Type 19 & 23	Type 19 & 23	3/8"	3/8"	3/8"	3/8"	3/8"
354	Type 19	Type 19	1/2"	1/2"	1/2"	1/2"	1/2"
355	Type 19	Type 19	5/8"	5/8"		5/8"	5/8"
356	Type 19	Type 19	3/4"	3/4"		3/4"	3/4"
357	Type 19	Type 19	7/8"	7/8"		7/8"	7/8"
358			3/8" & 1/2"	3/8" & 1/2"		3/8" - 1/2"	3/8" - 1/2"
359			3/8" & 1/2"	3/8" & 1/2"		3/8" - 7/8"	3/8" - 7/8"
360	Type 19	Type 19	3/8" & 1/2"	3/8" & 1/2"	3/8" & 1/2"		
363	Type 19	Type 19	3/8"	3/8"	3/8"	3/8"	3/8"
364	Type 19	Type 19	1/2"	1/2"	1/2"	1/2"	1/2"
420	Type 1	Type 1				3" - 36"	3" - 36"
425	Type 1	Type 1				1/2" - 36"	1/2" - 36"
426	Type 1	Type 1				1/2" - 36"	1/2" - 36"
430	Type 1	Type 1				1/2" - 12"	1/2" - 12"
440 & 440F	Type 1	Type 1				1/2" - 4"	1/2" - 4"
441	Type 1	Type 1				1/2" - 4"	1/2" - 4"
442	Type 1	Type 1					
450 & 450F	Type 1	Type 1	2 1/2" - 8"	2 1/2" - 8"	2 1/2" - 8"	1/2" - 36"	1/2" - 36"
450V						#1 & #2	#1 & #2
450T						#1 & #2	#1 & #2
451 & 451F	Type 1	Type 1	2 1/2" - 8"	2 1/2" - 8"	2 1/2" - 8"	1/2" - 36"	1/2" - 36"
453	Type 1	Type 1	2 1/2" - 8"	2 1/2" - 8"	2 1/2" - 8"	1/2" - 36"	1/2" - 36"
454	Type 1	Type 1	2 1/2" - 8"	2 1/2" - 8"	2 1/2" - 8"	1/2" - 36"	1/2" - 36"
455 & 456						#1 - #24	#1 - #24
703025 - 708362						703025 - 708362	
460	Type 44	Type 44				6" - 24"	6" - 24"
470 & 475	Type 43	Type 43				6" - 24"	6" - 24"
480	Type 41	Type 41				6" - 24"	
480D						6" - 24"	
485						2" - 42"	2" - 42"

Due to a mix of stock, you must specify "Buy American" or "100% Domestic" when ordering to ensure the material you receive is in compliance.

# COMPLIANCES & APPROVALS



Figure Number	ANSI/MSS SP-58	Federal Spec A-A-1192A	U.S. (UL) Listed	CAN. (CUL) Listed	FM Approved	Buy American	100% Domestic
486	Type 44	Type 44				2" - 42"	2" - 42"
487	Type 46	Type 46				2" - 42"	2" - 42"
488						30" - 72"	30" - 72"
490	Type 41	Type 41				6" - 24"	6" - 24"
495						6" - 24"	6" - 24"
496						#1 - #9	
508R	Type 12	Type 12					
510R	Type 12	Type 12					
512 & 512H	Type 12	Type 12					
520 & 521	Type 4	Type 4				1/2" - 36"	1/2" - 36"
522	Type 4	Type 4				3" - 42"	3" - 42"
525	Type 3	Type 3				3/4" - 24"	3/4" - 24"
526	Type 3	Type 3				6" - 36"	6" - 36"
550 & 551	Type 8	Type 8	3/4" - 8"	3/4" - 8"	3/4" - 8"	1/2" - 30"	1/2" - 30"
552 & 554	Type 8	Type 8					
553	Type 8	Type 8				1/2" - 30"	1/2" - 30"
R087100 - R412150						R087100 - R412150	
580						3" - 36"	3" - 36"
585						1" - 1 3/4"	1" - 1 3/4"
590						3" - 24"	3" - 24"
595						3/4" - 1 1/2"	3/4" - 1 1/2"
610 & 620	Type 21	Type 21				3" - 12"	3" - 12"
625						3/8" - 1 1/4"	3/8" - 1 1/4"
630	Type 30 (with Fig. 25)	Type 30 (with Fig. 25)					
632	Type 28 (with Fig. 35)	Type 28 (with Fig. 35)				A & B	A & B
633	Type 29 (with Fig. 35)	Type 29 (with Fig. 35)				A & B	A & B
635	Type 27	Type 27				3/8" - 3/4"	3/8" - 3/4"
651	Type 39	Type 39				3/4" - 12"	3/4" - 12"
653	Type 39	Type 39				3/4" - 36"	3/4" - 36"
654	Type 39	Type 39				3/4" - 36"	3/4" - 36"
655	Type 39	Type 39				1 1/4" - 36"	1 1/4" - 36"
656	Type 39	Type 39				2" - 36"	2" - 36"
658	Type 39	Type 39				4" - 36"	4" - 36"
670 - 678						#4 - #30	#4 - #30
690	Type 35	Type 35				1/2" - 24"	1/2" - 24"
825 & 826						1/4" - 4"	1/4" - 4"
830	Type 26	Type 26				1/2" - 4"	1/2" - 4"
835						1/2" - 4"	1/2" - 4"
836						1/8" - 2"	1/8" - 2"
837						1/2" - 4"	1/2" - 4"
840							
850	Type 31	Type 31				#1 - #3	#1 - #3
850C						3/8" & 1/2"	3/8" & 1/2"
855	Type 32	Type 32				#0 - #2	#0 - #2
860	Type 33	Type 33				#0 - #5	#0 - #5
870						1 1/2" - 12"	1 1/2" - 12"
871						1" - 6"	1" - 6"
874						2" - 12"	2" - 12"

Due to a mix of stock, you must specify "Buy American" or "100% Domestic" when ordering to ensure the material you receive is in compliance.

# COMPLIANCES & APPROVALS

Figure Number	ANSI/MSS SP-58	Federal Spec A-A-1192A	U.S. (UL) Listed	CAN. (CUL) Listed	FM Approved	Buy American	100% Domestic
875	Type 38	Type 38				2 1/2" - 36"	2 1/2" - 36"
876	Type 38	Type 38				2 1/2" - 36"	2 1/2" - 36"
877	Type 38 (with Fig. 880)	Type 38 (with Fig. 880)				1 1/2" - 4"	1 1/2" - 4"
878						2 1/2" - 36"	2 1/2" - 36"
879						2 1/2" - 36"	2 1/2" - 36"
880	Type 36	Type 36				2 1/2" - 36"	2 1/2" - 36"
882	Type 37	Type 37				2 1/2" - 36"	2 1/2" - 36"
883						2" - 24"	2" - 24"
885						3/8" - 1"	3/8" - 1"
900 & 900-1	Type 22	Type 22				3/8" - 2"	3/8" - 2"
903						3/8" - 2"	3/8" - 2"
904						3/8" - 2"	3/8" - 2"
905	Type 34	Type 34					
906	Type 34	Type 34	3/8"	3/8"	3/8"	3/8"	3/8"
910						#1 - #4	#1 - #4
920	Type 34	Type 34				3/8" - 7/8"	3/8" - 7/8"
925	Type 34	Type 34				3/8" & 1/2"	3/8" & 1/2"
930						3/8" - 2"	3/8" - 2"
935 & 936	Type 57	Type 57				1/2" - 1 1/2"	1/2" - 1 1/2"
940 & 941			3/8"	3/8"			
942							
945			3/8"	3/8"		3/8"	3/8"
946						3/8"	3/8"
950 & 951	Type 18	Type 18				1/4" - 3/4"	1/4" - 3/4"
950N & 951N						1/4" - 3/4"	1/4" - 3/4"
960	Type 13	Type 13				3/8" - 1 1/2"	3/8" - 1 1/2"
970 & 970F	Type 5	Type 5				1/2" - 8"	1/2" - 8"
973	Type 5	Type 5				1/2" - 8"	1/2" - 8"
990			3/8"	3/8"		3/8"	
995						3/8"	

Due to a mix of stock, you must specify "Buy American" or "100% Domestic" when ordering to ensure the material you receive is in compliance.

# INDEX



Figure Number	Page Number	Figure Number	Page Number	Figure Number	Page Number	Figure Number	Page Number	Figure Number	Page Number
010	115	110	30	426	48	590	77	879	101
015	116	110H	30	430	49	595	77	880	102
020	21	130	30	440	50	610	80	882	103
025	117	134	30	440F	50	620	80	883	104
030	118	135	31	441	50	625	81	885	105
031	119	136	31	442	51	630	81	900	106
035	120	141	35	450	52	632	82	900-1	106
040	121	141F	35	450F	52	633	82	903	107
045	122	143	36	450T	53	635	83	904	108
055	35	145	38	450V	53	651	89	905	109
070	32	151	37	451	52	653	89	906	109
075	32	151F	37	451F	52	654	90	910	109
076	33	152	37	453	52	655	90	920	110
077	33	154	37	454	52	656	91	925	110
10	20	155	38	455	54	658	91	930	111
15	20	160	84	456	54	670	92	935	111
15L	20	170	85	460	57	671	92	936	111
20	20	165	87	470	58	672	92	940	112
21	20	166	87	475	58	673	92	941	112
25	21	167	88	480	59	674	92	942	112
30	21	168	88	480D	59	675	92	945	112
35	22	180	38	485	64	676	92	946	112
35L	22	180F	38	486	60	677	92	950	113
36	23	181	38	487	61	678	92	950N	113
37	23	182	39	488	62	690	94	951	113
38	24	250	40	490	63	703025 - 708362	55	951N	113
40	25	259	40	495	65	825	78	960	31
41	25	270	41	496	65	826	78	970	56
47S	26	290	41	508R	67	830	78	970F	56
47W	26	345	42	510R	67	835	79	973	56
48	26	350	43	512	68	836	79	990	114
50	27	350 (1/4")	45	512H	68	837	79	995	114
50L	27	353	45	520	69	840	79	R087100 - R412150	75
55	27	354	45	521	69	850	96	TRH 2 - TRH 5	39
55L	27	355	45	522	70	850C	96		
90	28	356	45	525	71	855	97		
90S	28	357	45	526	72	860	97		
91	28	358	42	550	73	870	98		
93	28	359	43	551	73	871	98		
94	28	360	44	552	74	874	99		
95	29	363	46	553	73	875	99		
100	29	364	46	554	74	876	100		
104	29	420	47	580	76	877	100		
105	30	425	48	585	76	878	101		

PHD Manufacturing Inc. reserves the right to make changes to the specifications, materials, equipment, prices, or the availability of products at any time without prior notice. While every effort has been made to assure the accuracy of information contained in this catalog at the time of publication, we cannot accept responsibility for inaccuracies resulting from undetected errors or omissions.